

**HARD
WORK
INSPIRED**



**HAND
TOOLS
CATALOGUE
2024**

 **BELLOTA**

INDEX

► FOR AGRICULTURE

SOIL PREPARATION

HOES

Anti-rotation hoes	28/35
Anti-rotation forks	36
Hoes without anti-rotation system.....	37/38
Lightweight air hoe.....	39

AGRICULTURE SHOVELS

Shovels	40
Spades.....	41

FORKS

Manure fork.....	43
Fork stone and shovel.....	44
Garden forks	45
Hay rake.....	45

RAKES AND BROOMS

Rakes	46
Brooms	48
Plastic Brooms	49

GARDEN MAINTENANCE

% CHEMICALS RANGE

Phyto 0% long handle tools	51
----------------------------------	----

TOOLS FOR YOUR ORCHARD

Long wooden handle tools	52/53
Short handle tools: Fiberglass	54
Short handle tools: Aluminium	55

ELECTRICAL RANGE

CUTTING AND PRUNING

Cordless pruning shears	60
Electric chainsaw	61
Light electric tying machine.....	61
Pruning at height.....	61

ACCESSORIES ELECTRIC RANGE 62 |

POWER RANGE REPLACEMENT PARTS 63/64 |

MANUAL CUTTING AND PRUNING SCISSORS

MANUAL PRUNERS

Proline snips	65
Proline pruners	66
One hand pruning shears for garden Smart.....	67
Classic line pruners.....	68
Proline loppers	69
Proline Hedge shears.....	70
Garden Line loppers.....	71

Garden Line hedge shears.....	72
Garden Line grass shears.....	72
Shears spare parts.....	73/77

ACCESSORIES 77 |

OTHER CUTTING PRUNING TOOLS

PRUNING SAWS

Pruning saws	80/81
Pruning tools.....	82
Spare parts.....	82
Bow saw blades.....	83
Bow saws	84

AXES

Axes for chopping wood.....	85
Axes	86
Wedges.....	86
Machetes	87/90
Scythes.....	91
Sickles	92
Bill hooks.....	93

AGRICULTURAL FILES

Sharpening files.....	94/95
-----------------------	-------

FARRIER TOOLS

Farrier tools.....	98/99
--------------------	-------

ACCESSORIES FOR AGRICULTURE

Gloves	100
Kneepads	100
Lubricant.....	101
Lithium grease.....	101

SPRAYERS

Backsack sprayer	102
Parts for professional range sprayers	102
Pre-set pressure hand sprayer.....	103

BUCKETS 103 |

CLEANING

Pressure Washers	108
Vacuum cleaners.....	108
Accessories for high pressure cleaners	109
Accessories for vacuum cleaners	109

► FOR CONSTRUCTION

FORMWORK

CONSTRUCTION SHOVELS

Shovels	112/114
Scraper	114

FORMWORK TOOLS

Wrecking bar.....	115
Bending wrench.....	115

SCRAPERS AND RAKES

Scrapers	116
Rakes	116

NIPPERS

Concrete's nipper.....	117
Carpenter's nipper.....	117
Ceramic nipper	117

BOLT CUTTERS

.....	118
-------	-----

ORDER

Leather tool holder	119
Textile tool holder.....	120
Bags, Backpacks and Trolleys	121
Tool case.....	121

MASONRY

TROWELS

Trowels	122/124
Pointing trowels.....	125
Repointer.....	125

TROWELS, FLOATS, SCRAPERS AND SPATULAS

Plastering trowels	126/128
Finishing floats	128
Floats.....	129
Special tiling trowels.....	130/131
Notched trowels	131
Putty knives.....	132
Cleaning floats.....	132/133
Special tiling spatulas	133/134
Joint knives.....	134/135

CAULKING GUNS..... 135 |

HAMMERS AND STRIKING TOOLS

Sledge hammer	136
Picks	137
Drilling hammers	138
Pickaxes	139
Hammers	140/142
Non-toughened hammers	142
Nylon hammers	143
Rubber mallet	143

CHISELS

Point chisel	144
Chisel.....	144
Cold chisel.....	145
Brick chisel.....	145
Chisel for workshop	145/146
Mason pins.....	146

MIXERS..... 148/149 |

BUCKETS

Rubber buckets.....	150/153
Plastic buckets	152/153
Mud pan.....	153

TILING

TILE CUTTERS AND ACCESSORIES

Neo tile cutter	156
Lean tile cutter.....	157
Tech tile cutter.....	159
Pro tile cutter	160
Fit tile cutter.....	161
Pop tile cutter	162
Pass tile cutter.....	163
Scoring wheels	164/165

SPARE PARTS FOR TILE CUTTERS 166/167 |

LEVELLING SYSTEMS

Push & Level system	169
Wedge levelling system	170
Tile spacers	171
Wedges.....	171

ACCESSORIES FOR TILING

Tiling bucket	172
Sponges	172/173
Suction cups	173
Work bench	174
Tiling leveller.....	174
Joint scraper.....	174
Hole marker	174
Stencil.....	174

CARPENTRY

HACKSAWS, BLADES AND SAWS

Hacksaws.....	175
Saw for carpentry	176
Woodwork saw	176
Keyhole saw	176
Drywall saw	177

WOOD CHISELS..... 177 |

INDEX

► FOR CONSTRUCTION

DRYWALL

CUTTING TOOLS



Cutters.....	178
Snips.....	179
Stud crimper.....	179
Riveter.....	179

MEASUREMENT AND LEVELLING

MEASURING, MARKING AND LEVELLING



Laser levelling.....	182/183
Laser measurement.....	183
Long tapes.....	184
Short tapes.....	185
Pencils.....	186
Box levels.....	187
Cast levels.....	188
Squares.....	188
Chalk lines.....	189
Plumb bob and magnetic squares.....	190

CUTTING AND POLISHING

CUTTING



Diamond discs dry cutting.....	191/192
Diamond discs wet cutting.....	193

DIAMOND DRILL BITS..... 194/195

FLEXIBLE DIAMOND POLISHING DISCS..... 195

DIAMOND POLISHING BLOCKS..... 195



CLEANING

Pressure Washers.....	196
Vacuum cleaners.....	196
Accessories for high pressure cleaners.....	197
Accessories for vacuum cleaners.....	197

► FOR THE WORKSHOP

TOOLS FOR THE WORKSHOP

SCREWDRIVERS



Cabinet tip.....	200
Standard tip.....	200
Philips tip.....	200
Pozidriv tip.....	200
Screwdriver kit.....	200

WRENCHES



Double open-end wrench.....	201
Combination wrench.....	202
Double ring end wrench.....	202
Double head socket wrench.....	203
Stillson wrench.....	203
Adjustable wrench.....	204
Allen.....	205
Socket.....	206

PLIERS



Combination.....	207
Cutting plier.....	207
Nose plier.....	208
Slip joint plier.....	208
Insulated pliers.....	209
Electrician's shears.....	209

ABRASIVE AND GRINDING STRIP DISCS

ABRASIVE DISCS



Abrasive discs.....	210/212
Abrasive grinding discs.....	212

STRIP DISCS

Polyamide base.....	213
Fiberglass base.....	214

BRUSHING

BRUSHES



Handheld brushes.....	215/216
Diy brushes.....	216
Circular industrial brushes.....	217
Industrial cup brushes.....	217/218
Conical industrial brushes.....	218
Industrial nylon brushes.....	219

CLAMPING



BENCH VICES.....	220
------------------	-----

C CLAMPS.....	220/221
---------------	---------

FILES AND RASPS

FILES



Mechanical files.....	222/224
Needle files.....	225

CARPENTER'S RASPS.....	226
------------------------	-----

PLATE SANDERS AND RASPS.....	227
------------------------------	-----

► FOR YOUR SAFETY

FOOTWEAR



Classic range.....	234/236
Comp+ range.....	237/239
Nonmetal range.....	240
Click range.....	241
Agro range.....	242
Alltrack range.....	243
Flex range.....	244/245
Street & Industry range.....	246
Classic Run Running range.....	247
New Run Running range.....	248/249
Core range.....	250
Volta range.....	251
Race range.....	252
Chef range.....	253
Water range.....	254

LACES.....	255
------------	-----

INSOLES.....	256
--------------	-----



KNEE PADS.....	257
----------------	-----

HANDLES

For agriculture.....	258/265
For construction.....	266/270
For the workshop.....	271

POINT OF SALE

Displays and hooks.....	272/274
-------------------------	---------

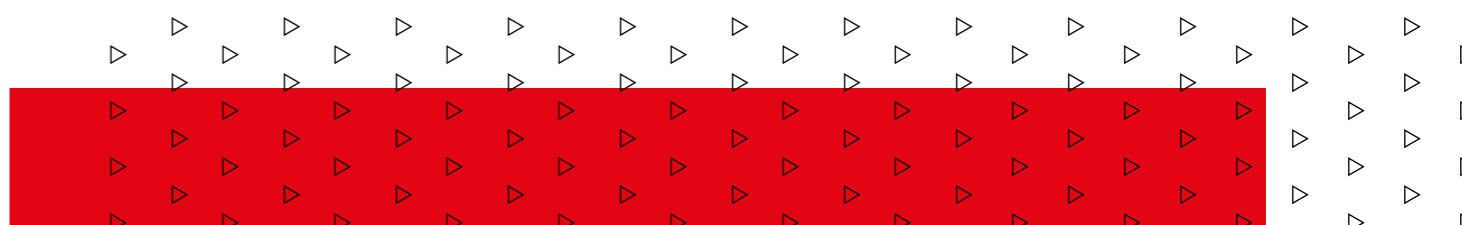
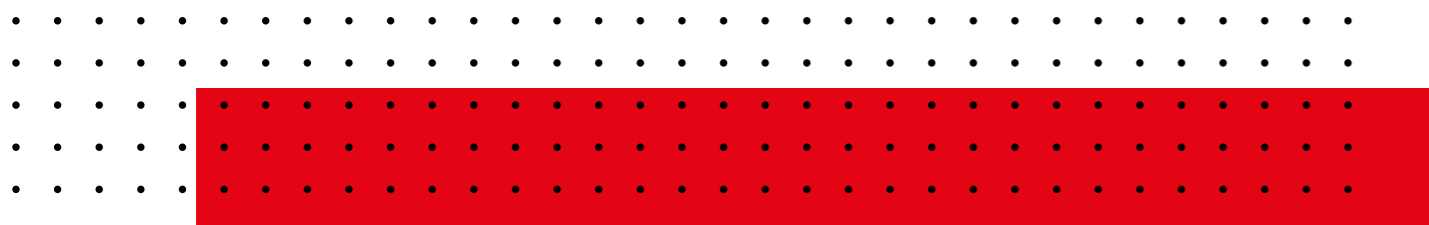

NEW ARRIVALS

AGRICULTURE

► THE CLASSIC CUT RANGE

Está especialmente diseñada para las personas que trabajan con fuerza y buen ritmo.

► THE EXPERT CUT RANGE

Specially designed for experienced people who are looking for a clean cut and smooth finish.



Pag. 80 / 81



POWER CUT

ONE PIECE FORGED BLADE FOR INCREASED DURABILITY.

0-LED DISPLAY WITH INDICATORS
- % OF BATTERY
- CUTTING HISTORY
- NO OF CURRENT CUTS
- ERROR CODE



FASTER SPEED

GREATER SENSITIVITY

GREATER CUTTING POWER

SAME CONSUMPTION

IMPROVED GREASE BOLT THAT KEEPS THE ENTIRE MECHANISM GREASED.

BI-MATERIAL HANDLE WITH A LARGER ELASTOMER SURFACE TO AVOID UNPLEASANT BUMPS IN THE HAND.

► ELECTRIC PRUNING SHEARS EPR238

DOUBLE OPENING-CUTTING CAPACITY



POSITION 1



POSITION 2

PROGRESSIVE CUTTING OPTION



ON



OFF

CUTTING PREVENTION SYSTEM



Pag. 60

► PRESSURE WASHER HL2400PROE 2.400W



HL1700E
1.700W



HL1400E
1.400W

Pag. 108 / 196

NEW ARRIVALS

CONSTRUCTION

► GREEN LASER LEVEL FOR TILING WORK NIV30360VT

- It projects its light up to 30 metres away and up to 50 metres with receiver.
- It has a 360° horizontal low level plane and two 360° vertical planes. 2 intensities.
- It has a rotating magnet, clamp, reflective plate, charged battery, charger and a sturdy carrying case.



Pag. 182



DFDIAM



DFDIAMSM14



TDIAM

► FLEXIBLE DIAMOND DISCS DFDIAM

► HOLDER FOR FLEXIBLE DIAMOND DISCS DFDIAMSM

► DIAMOND BLOCKS TDIAM

Pag. 195

► MIXER M14 1.400W

TWO SPEEDS

- 580 / 0-780 rpm → M14
- 0-560 / 0-760 rpm → M14110V
- 0-620 / 0-820 rpm → M16

Pag. 148

M16 1.600 W



IMPACT-RESISTANT BUMPERS.
ANTI-FALL SUPPORTS.

SOFT START.
SPEED REGULATOR AND
SAFETY SWITCH.

ERGONOMIC GRIP
WIDE HANDLE.
BI-MATERIAL GRIP.

M14 1.400 W



QUICK CHANGE
EASY ACCESS
BRUSHES.

► ROD

TYPE K4, METRIC M14.
590 MM X DIAMETER 120MM → M14
590 MM X DIAMETER 140MM → M16



► LEAN

Pag. 158



LEANLIFT



LEAN320



LEANWB



LEANCART



Only
the best tools
for your harvest

**FOR
AGRICULTURE**

▶ HOE WITH ANTI-ROTATION SYSTEM



▶ IT DOESN'T ROTATE OR GET LOOSE

THE HEAD AND THE HANDLE WILL BE ONE.

▶ LONGER-LASTING

THE JOINT IS INSEPARABLE, HEAT AND MOISTURE RESISTANT.



▶ HANDLE MADE OUT OF ONE SINGLE PIECE

- ▶ The plastic is injected at a high pressure into the pores of the wood.
- ▶ The joint is inseparable, heat and moisture resistant.

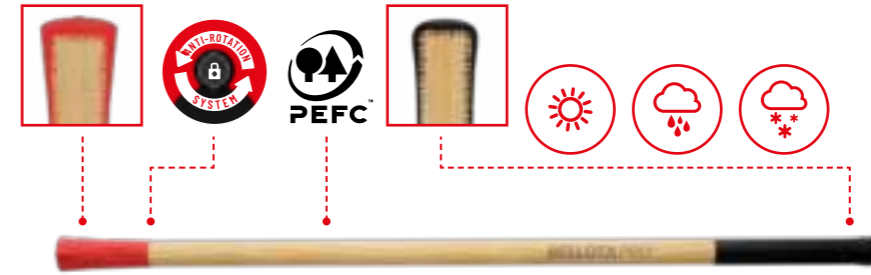

▶ CHOOSE THE PERFECT COMBINATION

Choosing a handle for your hoe will be easier. There are 3 sizes of heads with the ANTI-ROTATION SYSTEM to choose from.

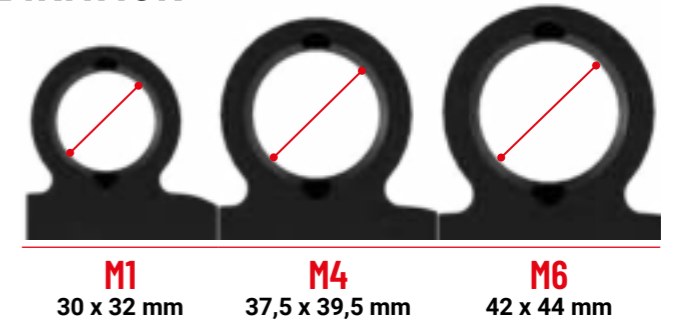

Combine it with one of these handles that have the ANTI-ROTATION SYSTEM.



M1	M4	M6
30 x 32 mm	37,5 x 39,5 mm	42 x 44 mm
M1 -1.000 mm	M4 -1.000 mm	M6 -1.000 mm
M1 -1.200 mm	M4 -1.200 mm	M6 -1.200 mm
M1 -1.400 mm	M4 -1.400 mm	M6 -1.400 mm

And now you have it!
A safe bet.

▶ OR PUT YOUR OWN HANDLE ON IT

The hoe heads with the ANTI-ROTATION SYSTEM are compatible with any handle.

The slots make it easier for you to use your regular wedges and accessories.

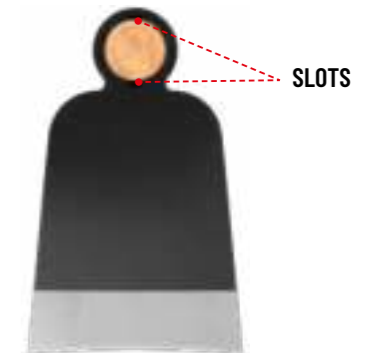

HOES

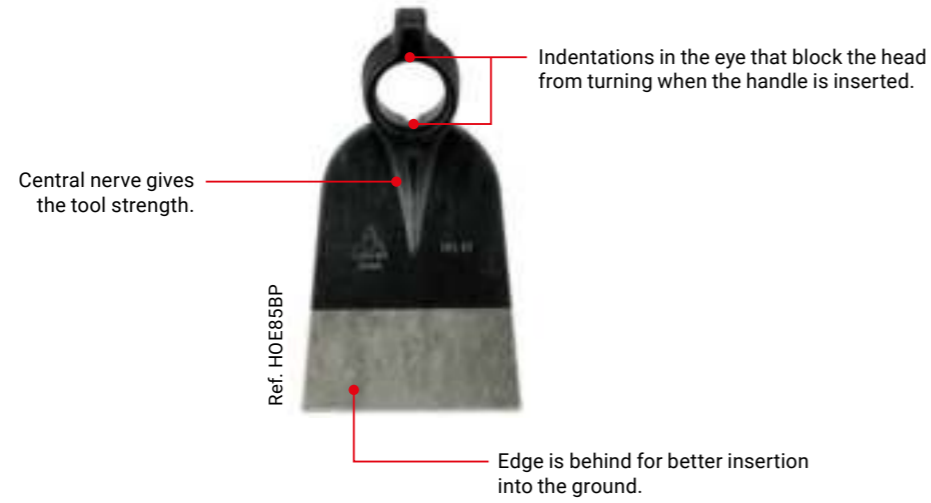

ANTI-ROTATION HOES

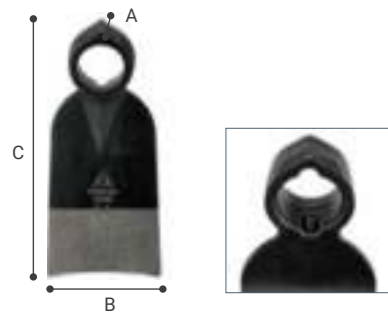

▶ HOE 1

REF.	€	8 41 4299	g	A mm	B mm	C mm	M
HOE1AP	19,06	694772	12	380	30	80	175 M1
HOE1BP	19,66	694734	12	430	30	90	200 M1
HOE1CP	21,76	694697	12	650	42	105	220 M4

For precision tasks.

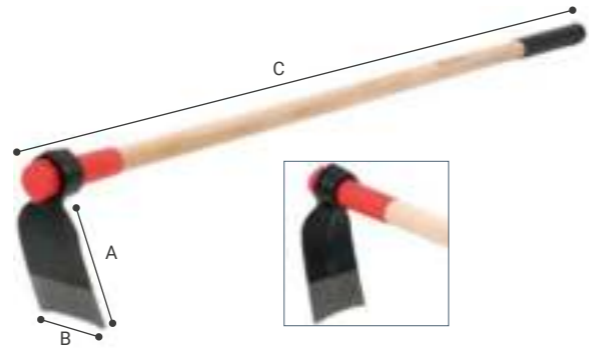

▶ HOE WITH HANDLE 1

REF.	€	8 41 4299	g	A mm	B mm	C mm	M
HOE1AW1200AP	30,54	694758	2	1.182	168	80	1.200 M1
HOE1BW1200AP	31,17	694710	2	1.137	188	89	1.200 M1



▶ HOE 2

REF.	€	8 41 4299	g	A mm	B mm	C mm	M
HOE2AP	25,08	694673	12	810	40	140	220 M4
HOE2BP	25,40	694659	12	1.000	40	145	245 M4



▶ HOE 3

REF.	€	8 41 4299	g	A mm	B mm	C mm	M
HOE3AP	29,29	694635	12	970	42	180	220 M4
HOE3BP	29,84	695007	12	940	40	190	240 M4

For turning the soil, weeding or digging over.



▶ HOE 4

REF.	€	8 41 4299	g	A mm	B mm	C mm	M
HOE4AP	28,99	694598	12	1.100	42	165	250 M4
HOE4BP	30,66	694574	12	1.260	50	180	270 M4

To make ridges.



▶ HOE 5

REF.	€	8 41 4299	g	A mm	B mm	C mm	M
HOE5P	37,61	694536	12	1.430	40	120	290 M6

For digging trenches.



▶ HOE 7

REF.	€	8 41 4299	g	A mm	B mm	C mm	M
HOE7AP	19,11	694499	12	370	30	50	195 M1

Small hoe for precision tasks.



▶ HOE 10

REF.	€	8 41 4299	g	A mm	B mm	C mm	M
HOE10AP	33,24	694413	12	1.250	38	145	270 M4



▶ HOE WITH HANDLE 4

REF.	€	8 41 4299	g	A mm	B mm	C mm	M
HOE4BW1400AP	47,90	694550	2	2.260	248	179	1.400 M4



▶ HOE WITH HANDLE 5

REF.	€	8 41 4299	g	A mm	B mm	C mm	M
HOE5W1400AP	56,96	694512	2	2.432	269	118	1.400 M6



▶ HOE 8

REF.	€	8 41 4299	g	A mm	B mm	C mm	M
HOE8AP	21,92	694475	12	590	35	80	225 M4
HOE8BP	22,48	694451	12	710	35	100	240 M4
HOE8CP	26,65	694437	12	930	35	120	260 M4



▶ HOE 11

REF.	€	8 41 4299	g	A mm	B mm	C mm	M
HOE11AP	39,44	694390	12	1.800	50	120	320 M6

For digging and planting.



▶ HOE 43

REF.	€	8 41 4299	g	A mm	B mm	C mm	M
HOE430P	36,75	694376	12	1.370	75	45	295 M6
HOE43BP	40,39	694352	12	1.520	60	185	305 M6

To make ridges and move soil.



▶ HOE 53

REF.	€	8 41 4299	g	A mm	B mm	C mm	M
HOE53BP	32,62	694338	12	1.100	55	190	305 M4
HOE53AP	29,23	695038	12	1.100	55	190	305 M4

For digging and making grooves.



▶ HOE 58

REF.	€	8 41 4299	g	A mm	B mm	C mm	M
HOE580P	31,36	694314	12	1.050	50	160	265 M4
HOE58AP	37,01	694291	12	1.360	60	180	285 M4



▶ HOE 69

REF.	€	8 41 4299	g	A mm	B mm	C mm	M
HOE69AP	36,36	694277	12	1.350	28	165	360 M4
HOE69BP	40,10	694253	12	1.660	35	180	420 M6

Navarra pattern.

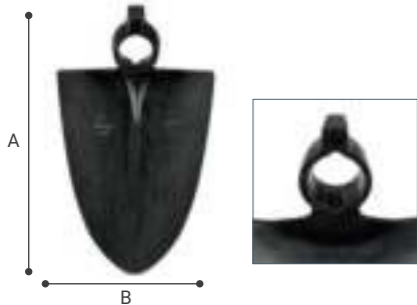

▶ HOE 72

REF.	€	8 41 4299	g	A mm	B mm	C mm	M
HOE72AP	26,85	694239	12	800	115	170	295 M4
HOE72BP	29,05	694215	12	840	33	180	310 M4
HOE72CP	30,84	694192	12	1.150	55	200	330 M4
HOE72DP	34,53	694178	12	1.430	50	220	360 M4

Galicia pattern.



▶ HOE 77

REF.	€	8 41 4299	g	A mm	B mm	C mm	M
HOE77DP	39,77	694154	6	1.520	85	225	350 M4

For potatoe growing.



▶ HOE 80

REF.	€	8 41 4299	g	A mm	B mm	C mm	M
HOE80AP	29,05	694130	12	850	34	160	250 M4
HOE80BP	29,74	694116	12	970	34	170	250 M4
HOE80EP	34,06	694093	12	1.340	55	190	280 M4
HOE80HP	38,12	694079	12	1.370	60	200	310 M4



▶ HOE 81

REF.	€	8 41 4299	g	A mm	B mm	C mm	M
HOE81000P	26,92	694055	12	820	60	165	250 M4
HOE8100P	28,86	694031	12	930	40	180	270 M4
HOE81AP	34,34	693997	12	1.210	30	220	305 M4
HOE810P	30,22	694017	12	1.000	40	200	280 M4



▶ HOE WITH HANDLE 81

REF.	€	8 41 4299	g	A mm	B mm	C mm	M
HOE81000W1000AP	38,03	693973	2	1.680	232	168	1.000 M4
HOE81000W1200AP	40,05	704112	2	1.760	232	168	1.200 M4
HOE810W1200AP	43,49	693935	2	2.030	261	200	1.200 M4



▶ HOE 83

REF.	€	8 41 4299	g	A mm	B mm	C mm	M
HOE83AP	30,96	693898	12	1.040	38	140	260 M4

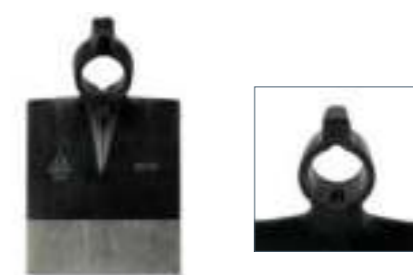

▶ HOE 82

REF.	€	8 41 4299	g	A mm	B mm	C mm	M
HOE82BP	24,85	693911	12	750	45	140	235 M4



▶ HOE 84

REF.	€	8 41 4299	g	A mm	B mm	C mm	M
HOE84AP	24,57	693874	12	690	42	135	210 M4
HOE84BP	26,05	693850	12	800	42	150	210 M4
HOE84CP	26,19	693836	12	840	45	140	225 M4



▶ HOE 85

REF.	€	8 41 4299	g	A mm	B mm	C mm	M
HOE85AP	23,28	693799	12	700	34	115	220 M4
HOE85BP	23,80	693775	12	740	34	125	230 M4
HOE85CP	26,71	693737	12	820	34	135	240 M4



▶ HOE WITH HANDLE 85

REF.	€	8 41 4299	g	A mm	B mm	C mm	M
HOE85BW1200AP	37,05	693751	2	1.670	206	122	1.200 M4
HOE85BW1000AP	34,71	693713	2	1.590	206	122	1.000 M4



▶ HOE 87

REF.	€	8 41 4299	g	A mm	B mm	C mm	M
HOE87BP	22,77	693683	12	1.070	40	150	260 M4
HOE87CP	25,57	693669	12	1.190	38	165	280 M4
HOE87DP	28,13	693645	12	1.340	60	180	300 M4
HOE87EP	31,36	693621	12	1.500	50	185	320 M4
HOE87FP	34,64	693607	6	1.810	55	195	350 M6
HOE87GP	35,93	693584	6	1.990	90	240	365 M6

For asparagus growing.



▶ HOE 89

REF.	€	8 41 4299	g	A mm	B mm	C mm	M
HOE89AP	24,20	693560	12	690	45	120	200 M4



▶ CAVEC HOE96AWP

REF.	€	8 41 4299	g	A mm	B mm	C mm	M
HOE96AWP	16,30	676334	6	1.475	230	285	740

Majorcan Càvec.

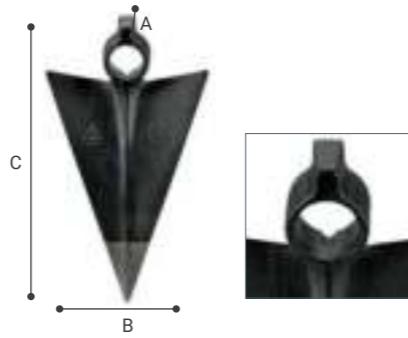

▶ HOE 150

REF.	€	8 41 4299	g	A mm	B mm	C mm	M
HOE150AP	29,59	693423	12	950	35	190	330
HOE150CP	34,96	693409	12	1.170	50	230	355

For digging trenches.



▶ HOE 182

REF.	€	8 41 4299	g	A mm	B mm	C mm	M
HOE182P	19,20	693386	12	400	29	120	210

For digging trenches and cleaning vine plants.



▶ HOE 228

REF.	€	8 41 4299	g	A mm	B mm	C mm	M
HOE228AP	25,02	693362	12	490	35	75	270
HOE228BP	26,43	693324	12	540	45	80	295
HOE228CP	28,46	693300	12	640	50	85	320
HOE228DP	32,13	693287	12	770	50	100	330

For gardening tasks. Dual use tool: hoe for turning the soil and fork for cleaning and taking out roots.



▶ WEEDER WITH HANDLE 228

REF.	€	8 41 4299	g	A mm	B mm	C mm	M
HOE228AW1200AP	36,80	693348	2	1.167	268	80	1.200
HOE228AW400P	28,38	695052	2	660	268	80	400
HOE228AW1000AP	35,49	693263	2	1.090	268	80	1.000

For gardening tasks. Dual use tool: hoe for turning the soil and fork for cleaning and taking out roots.



▶ HOE 242

REF.	€	8 41 4299	g	A mm	B mm	C mm	M
HOE2420P	17,49	693003	12	230	35	55	140
HOE242AP	19,25	692983	12	400	29	70	170

Small model for parterre gardens.



▶ HOE WITH HANDLE 242

REF.	€	8 41 4299	g	A mm	B mm	C mm	M
HOE2420W335P	20,94	692969	3	475	137	54	335
HOE242AW360P	22,96	692945	3	565	165	70	360

Small model for parterre gardens.



▶ HOE 229

REF.	€	8 41 4299	g	A mm	B mm	C mm	M
HOE229AP	27,02	693249	12	640	32	110	310

For gardening tasks. Dual use tool: Pick hoe for planting and fork for taking out roots.



▶ WEEDER 230

REF.	€	8 41 4299	g	A mm	B mm	C mm	M
HOE230AP	22,84	693201	12	470	30	70	260
HOE230BP	24,96	693188	12	530	32	75	290

For gardening tasks. Dual use tool: hoe for turning the soil and tong for preparing the soil and planting.



▶ WEEDER 232

REF.	€	8 41 4299	g	A mm	B mm	C mm	M
HOE232AP	17,14	693126	12	320	29	70	160
HOE232BP	18,56	693102	12	360	29	75	175
HOE232CP	19,77	693089	12	400	29	80	190

Small model for parterre gardens.



▶ HOE WITH HANDLE 325

REF.	€	8 41 4299	g	A mm	B mm	C mm	M
HOE325800W1200AP	35,85	692723	2	1.790	243	120	1.200



▶ WEEDER WITH HANDLE 229

REF.	€	8 41 4299	g	A mm	B mm	C mm	M
HOE229AW1200AP	38,89	693225	2	1.257	301	115	1.200

For gardening tasks. Dual use tool: Pick hoe for planting and fork for taking out roots.



▶ WEEDER WITH HANDLE 230

REF.	€	8 41 4299	g	A mm	B mm	C mm	M
HOE230AW400P	28,56	693164	2	670	252	71	400
HOE230AW1000AP	33,39	693140	2	1.080	252	71	1.000
HOE230AW1200AP	34,27	695076	2	1.147	252	71	1.200

For gardening tasks. Dual use tool: hoe for turning the soil and fork for cleaning and taking out roots.



▶ WEEDER WITH HANDLE 232

REF.	€	8 41 4299	g	A mm	B mm	C mm	M
HOE232AW400P	22,46	693065	2	555	155	70	400

Small model for parterre gardens.



▶ HOE 326

REF.	€	8 41 4299	g	A mm	B mm	C mm	M
HOE326P	27,02	692709	12	550	30	170	195



▶ HOE 320

REF.	€	8 41 4299	g	A mm	B mm	C mm	M
HOE320P	36,15	692808	12	1.210	55	180	300 M4

For asparagus growing.



▶ HOE 325

REF.	€	8 41 4299	g	A mm	B mm	C mm	M
HOE325800P	20,96	692785	12	900	60	120	245 M4
HOE3251000P	24,20	692761	12	1.030	45	140	270 M4
HOE3251200P	26,26	692747	12	1.180	38	160	290 M4



▶ MATTOCK 801

REF.	€	8 41 4299	g	A mm	B mm	C mm	M
801-0	58,86	114300	6	2.210	85	85	400

Dual-use tool: axe and hoe. Forestry tasks, roots cleaning and cutting.



▶ MATTOCK 805

REF.	€	8 41 4299	g	A mm	B mm	C mm	M
805-A	57,18	114508	6	2.100	85	65	395 M6

Dual-use tool: axe and hoe. Forestry tasks, roots cleaning and cutting.



▶ HOE 327

REF.	€	8 41 4299	g	A mm	B mm	C mm	M
HOE327AP	28,39	692686	12	850	35	185	230 M4



▶ HOE 328

REF.	€	8 41 4299	g	A mm	B mm	C mm	M
HOE328BP	28,62	692662	12	960	40	220	260 M4

For tuber growing. Suitable for working gravel soil.



▶ MATTOCK 820

REF.	€	8 41 4299	g	A mm	B mm	C mm	M
820	52,32	114706	6	1.500	85	65	370 M6

Dual-use tool: axe and hoe. Forestry tasks, roots cleaning and cutting.



▶ DIBBER 262

REF.	€	8 41 4299	g	A mm	B mm	C mm	M
262	37,49	113105	12	694	270	170	250

For transplanting. Weeding and planting



▶ HOE 344

REF.	€	8 41 4299	g	A mm	B mm	C mm	M
HOE344600P	21,45	692501	12	560	35	75	300 M1

Multiple purpose tool: hoe, preparing the soil on the surface, weeding fork side to take out roots and crust breakage.



▶ HOE WITH HANDLE 344

REF.	€	8 41 4299	g	A mm	B mm	C mm	M
HOE344600W1000AP	30,37	692488	2	1.150	297	76	1.000 M1

Multiple purpose tool: hoe, preparing the soil on the surface, weeding fork side to take out roots and crust breakage.



▶ DIBBER 322

REF.	€	8 41 4299	g	A mm	B mm	C mm	M
322-A	29,83	114003	12	450	130	120	365

For transplanting. Weeding and planting.



ANTI-ROTATION FORKS

- Manufactured with Special Bellota Steel.
- Forged in one single piece, unbreakable.
- 3+ steel treatment for a longer tool life: doesn't break, warp or wear away.
- Polished and sharpened for easy insertion into the ground.
- Special paint and varnish to prevent breakage of the tool.

Uses:

- For aerating the soil and removing tubers.

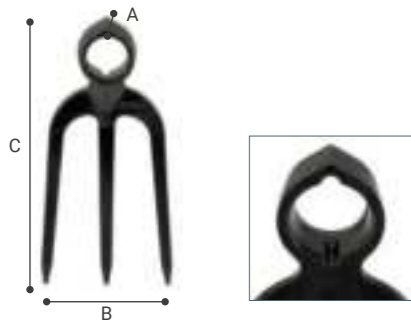

► FORK 1020

REF.	€	8 41 4299	g	A mm	B mm	C mm	M
HFK1020AP	31,75	710793	12	910	40	125	255 M4

For soil aerating and tubers removal.



► FORK 1002

REF.	€	8 41 4299	g	A mm	B mm	C mm	M
HFK1002AP	51,98	710694	6	1.730	90	135	320 M6

For soil aerating and tubers removal.



► FORK 1018

REF.	€	8 41 4299	g	A mm	B mm	C mm	M
HFK1018P	50,06	710779	12	1.060	75	125	325 M4

For soil aerating and tubers removal.

HOES WITHOUT ANTI-ROTATION SYSTEM



► HOE 90

REF.	€	8 41 4299	g	A mm	B mm	C mm	M
HOE90B	36,86	693546	12	920	60	120	320 M4

Double use, for breaking and turning the soil.



► HOE 91

REF.	€	8 41 4299	g	A mm	B mm	C mm	M
HOE91A	35,24	693522	12	1.120	30	320	160 M4
HOE91B	42,56	693508	12	1.400	20	390	190 M4

For bannana growing.



► HOE 95

REF.	€	8 41 4299	g	A mm	B mm	C mm	M
HOE95A	24,44	710632	12	930	40	180	270 M6

Morocco model.



► HOE 108

REF.	€	8 41 4299	g	A mm	B mm	C mm	M
HOE108A	34,96	693461	12	930	40	180	270 M108

For asparagus growing.



► HOE 127

REF.	€	8 41 4299	g	A mm	B mm	C mm	M
HOE127A	32,22	693447	12	860	110	155	290 M127

Cataluña model.



► HOE 252

REF.	€	8 41 4299	g	A mm	B mm	C mm	M
HOE252A	27,44	708592	12	740	40	190	200 M6
HOE252B	29,29	708622	12	900	40	200	210 M6

Africa model.



▶ HOE 263

REF.	€	8 41 4299	g	A mm	B mm	C mm	M
HOE263A	29,95	708448	12	1.020	45	295	M6
HOE263B	31,51	708462	12	910	45	325	M6
HOE263C	36,75	708486	12	1.470	45	350	M6
HOE263D	37,88	708509	6	1.610	45	355	M6



▶ MATTOCK 240

REF.	€	8 41 4299	g	A mm	B mm	C mm	M
HOE240	39,16	693041	12	680	70	75	M1

Pulaski, Forestry purpose. Multiple purpose tool; cutting, scrapping and digging.



▶ HOE 332

REF.	€	8 41 4299	g	A mm	B mm	C mm	M
HOE332A	34,42	692648	12	1.340	50	215	M332EM
HOE332B	36,17	692624	12	1.400	45	240	M332EM
HOE332D	39,23	692600	6	1.880	50	280	M332EM

Arab Model.



▶ HOE 337

REF.	€	8 41 4299	g	A mm	B mm	C mm	M
HOE337A	24,70	692587	12	1.180	40	190	M4

Greek Model.



▶ HOE 338

REF.	€	8 41 4299	g	A mm	B mm	C mm	M
HOE3380	24,34	692563	12	1.040	40	200	M4
HOE338A	25,38	692549	12	1.200	40	215	M4

Greek Model.



▶ HOE 340

REF.	€	8 41 4299	g	A mm	B mm	C mm	M
HOE340A	26,65	692525	12	850	50	168	M4

Greek Model.

LIGHTWEIGHT AIR HOE

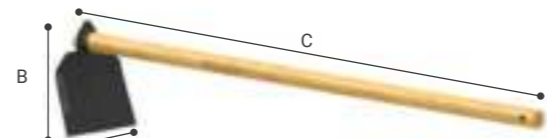

▶ LIGHTWEIGHT AIR HOE WITH HANDLE L1CM1200

REF.	€	8 41 4299	g	A mm	B mm	C mm	M
L1CM1200	29,42	651706	2	1.210	190	1.200	ML1200

To till the soil, weed and hoe. Wide and short blade for general maintenance jobs. Users can work standing upright, which prevents back injury.



▶ LIGHTWEIGHT AIR HOE WITH HANDLE L2CM500

REF.	€	8 41 4299	g	A mm	B mm	C mm	M
L2CM500	27,81	651751	2	600	174	110	ML500

To till the soil, weed, hoe and detailed jobs. Short and narrow blade for specific maintenance Work It can be used with one hand for detailed finishes.



▶ LIGHTWEIGHT AIR HOE WITH HANDLE L3CM1200

REF.	€	8 41 4299	g	A mm	B mm	C mm	M
L3CM1200	34,17	651799	2	1.230	240	140	ML1200

To dig trenches. Long and wide blade for construction and tilling the soil. Users can work standing upright, which prevents back injury.



▶ LIGHTWEIGHT AIR HOE WITH HANDLE L4CM500

REF.	€	8 41 4299	g	A mm	B mm	C mm	M
L4CM500	32,58	651836	2	690	240	100	ML500

To dig trenches. Long and narrow blade to dig narrow ditches and gain access to difficult areas. It can be used with one hand for detailed finishes



▶ LIGHTWEIGHT AIR HOE WITH HANDLE L5CM1200

REF.	€	8 41 4299	g	A mm	B mm	C mm	M
L5CM1200	32,58	651881	2	1.400	240	180	ML1200

To make ridges. Extra thick and long blade for more general work that involves moving the earth. It can be used standing upright to prevent back injury.

SPARE PARTS



▶ LIGHTWEIGHT AIR HOE WITH HANDLE L1CM1200

REF.	€	8 41 4299	g	A mm	B mm
L1	20,99	651683	3	Wide and short blade	620
L2	19,54	651737	3	Short and narrow blade	370
L3	25,75	651775	3	Logn and wide blade	640
L4	22,91	651812	3	Long and narrow blade	460
L5	24,64	651850	3	Extra-thick and long blade	810

AGRICULTURE SHOVELS

SHOVELS

Shovels:

- Manufactured with Special Bellota Steel.
- Varnished beech handle: light and comfortable touch. PEFC certified.

Steel shovels:

- Manufactured with Special Bellota Steel.
- 3+ steel treatment for a longer tool life: doesn't break, warp or wear away.
- Perfect joint between blade and handle for safety of the user.
- Two types of handles:
 - Varnished beech handle: light and comfortable touch. PEFC certified.
 - Hollow fiberglass handles with two grips for a better hold. Ring handle with elastomer for a better grip.

Aluminium shovels:

- Highest quality aluminium shovels: Lightweight and easy to clean.
- Great elasticity, bending resistance.
- Very strong, riveted holder ensuring the perfect joint between blade and handle.
- Varnished beech handle: light and comfortable touch. PEFC certified.

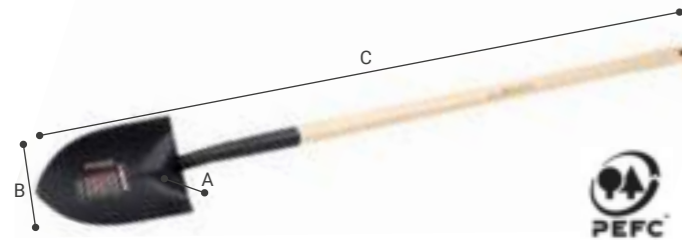

FORGED SHOVEL 5609

REF.	€	8 41 4299	g	A mm	B mm	C mm	M
5609 ML	58,56	502305	2	2.230	120	190	M5609L

Forestry use: for fire fighting, cutting small branches and face shield.



LONG FIBERGLASS HANDLE POINTED SHOVEL 3100

REF.	€	8 41 4299	g	A mm	B mm	C mm
3100MFV	33,93	533866	6	2.180	130	230

Ideal curved shape for digging out soil. Rugged design for easy soil penetration.



D FIBERGLASS HANDLE POINTED SHOVEL 3103

REF.	€	8 41 4299	g	A mm	B mm	C mm
3103 MFVA	25,21	550726	2	2.280	130	230

For digging and transplanting. Rugged design for easy soil penetration.



D FIBERGLASS HANDLE SQUARE SHOVEL 3104

REF.	€	8 41 4299	g	A mm	B mm	C mm
3104 MFVA	28,00	550740	2	2.140	100	240

For soil and manure transfer. Rugged design for easy soil penetration



MULTIPURPOSE SHOVEL 5526

REF.	€	8 41 4299	g	A mm	B mm	C mm
5526	11,36	371819	6	940	50	150

For digging and soil, sand and snow transfer. Light, practical and easy to use.



D HANDLE FOR ALUMINIUM SHOVEL 5520

REF.	€	8 41 4299	g	A mm	B mm	C mm	M
5520 MA	48,60	503296	6	1.960	180	360	M5520A M5520L



LONG HANDLE FOR ALUMINIUM SHOVEL 5520

REF.	€	8 41 4299	g	A mm	B mm	C mm	M
5520 ML	50,54	503104	6	2.000	200	375	M5520A M5520L



D HANDLE ALUMINIUM SHOVEL 5522

REF.	€	8 41 4299	g	A mm	B mm	C mm	M
5522 MA	41,09	103182	6	1.630	200	325	M5520A M5520L

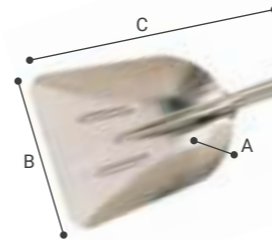

ALUMINIUM SHOVEL 5522

REF.	€	8 41 4299	g	A mm	B mm	C mm	M
5522 SM	28,47	674132	54	780	120	330	M5520A M5520L



D HANDLE ALUMINIUM SHOVEL 5525

REF.	€	8 41 4299	g	A mm	B mm	C mm	M
5525 MA	34,07	336696	6	1.010	130	230	M5525A

SPADES

Spades:

- Manufactured with Special Bellota Steel.
- Forged in one single piece, unbreakable.
- Varnished Beech handle: light and comfortable touch. PEFC certified.

Steel Spades:

- Manufactured with Special Bellota Steel.
- 3+ steel treatment for a longer tool life: doesn't break, warp or wear away.
- Perfect joint between blade and handle for safety of the user.
- Two types of handles:
 - Varnished Beech handle: light and comfortable touch. PEFC certified.
 - Hollow fiberglass handles with two grips for a better hold. Ring handle with elastomer for a better grip.

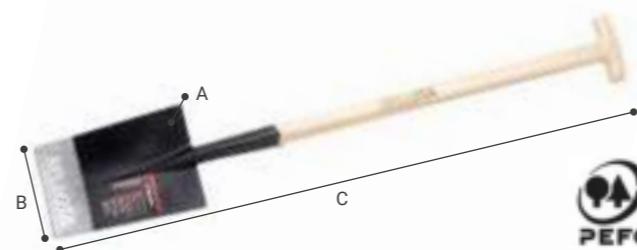

T HANDLE FORGED SPADE 5604

REF.	€	8 41 4299	g	A mm	B mm	C mm	M
5604-24 MM	63,63	125207	6	2.180	36	180	M5604M M5604A M5604L M5604ASB M5604LSB
5604-26 MM	65,25	125603	6	2.140	40	195	M5604M M5604A M5604L M5604ASB M5604LSB

* During this year the box units will be change from 6 to 2.



D HANDLE FORGED SPADE 5604

REF.	€	8 41 4299	g	A mm	B mm	C mm	M
5604-24 MA	70,02	125306	4	2.290	42	180	M5604M M5604A M5604L M5604ASB M5604LSB
5604-26 MA	72,33	125702	4	2.580	50	190	M5604M M5604A M5604L M5604ASB M5604LSB

* During this year the box units will be change from 4 to 2.



▶ LONG HANDLE FORGED SPADE 5604

REF.	€	g	A mm	B mm	C mm	M		
5604-24 ML	66,42	125405	6	1.990	55	180	1.270	M5604M M5604A M5604L M5604ASB M5604LSB
5604-26 ML	66,17	125801	6	2.380	42	190	1.320	M5604M M5604A M5604L M5604ASB M5604LSB

* During this year the box units will be change from 6 to 2.



▶ LONG FIBERGLASS HANDLE SPADE 3101

REF.	€	g	A mm	B mm	C mm		
3101MFV	33,93	533880	6	1.835	130	180	1.500

For transplanting, ground cutting and outlining. Rugged design for easy soil penetration.



▶ T HANDLE SPADE 5573

REF.	€	g	A mm	B mm	C mm	M		
5573-26 MM	30,80	124804	6	1.670	50	195	955	M5604M M5604A M5604L M5604ASB M5604LSB

* During this year the box units will be change from 6 to 2.



▶ D HANDLE SPADE 5573

REF.	€	g	A mm	B mm	C mm	M		
5573-26 MA	34,33	124903	4	2.110	40	190	1.090	M5604M M5604A M5604L M5604ASB M5604LSB

* During this year the box units will be change from 4 to 2.



▶ LONG HANDLE SPADE 5573

REF.	€	g	A mm	B mm	C mm	M		
5573-26 ML	30,30	125009	6	1.940	40	190	1.230	M5604M M5604A M5604L M5604ASB M5604LSB

* During this year the box units will be change from 6 to 2.



▶ SPADE 5573

REF.	€	g	A mm	B mm	C mm	M		
5573-26 SM	21,69	155198	12	1.080	40	200	350	M5604M M5604A M5604L M5604ASB M5604LSB

FORKS

MANURE FORK

- Manufactured with Special Bellota Steel.
- Forged in one single piece, unbreakable.
- 3+ steel treatment for a longer tool life: doesn't break, warp or wear away.
- Sharpened and tempered prongs along its entire length.
- Special paint to prevent breakage of the tool.
- Ash handles, light and comfortable touch. PEFC certified.

Uses:

- For moving hay and manure.
- For moving bales.

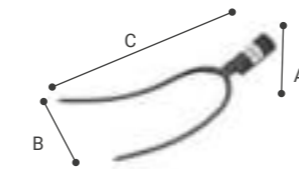

▶ MANURE FORK 901-2

REF.	€	g	A mm	B mm	C mm	L mm	M		
901-2	17,60	156119	12	460	170	150	380	30	M901LR120 M901LC135 M901AC75 M901LR120SB

For burden handling.



▶ MANURE FORK 901-3

REF.	€	g	A mm	B mm	C mm	L mm	M		
901-3	20,69	156126	12	610	170	200	390	32	M901LR120 M901LC135 M901AC75 M901LR120SB

For hay and manure collecting. For burden handling.



▶ MANURE FORK 901-3A

REF.	€	g	A mm	B mm	C mm	L mm	M		
901-3A	27,65	156133	12	810	90	280	520	41	M901LR120 M901LC135 M901AC75 M901LR120SB

For hay and manure collecting. For burden handling. Extra working width.



▶ MANURE FORK 901-4

REF.	€	g	A mm	B mm	C mm	L mm	M		
901-4	21,13	156157	12	900	39	225	485	32	M901LR120 M901LC135 M901AC75 M901LR120SB

For hay and manure collecting.



▶ MANURE FORK 901-3B

REF.	€	g	A mm	B mm	C mm	L mm	M		
901-3B	35,89	156140	6	980	270	270	480	41	M901LR120 M901LC135 M901AC75 M901LR120SB

Additional prong for easy burden collection.



▶ MANURE FORK 901-4

REF.	€	g	A mm	B mm	C mm	L mm	M		
901-4	21,13	156157	12	900	39	225	485	32	M901LR120 M901LC135 M901AC75 M901LR120SB

For hay and manure collecting.

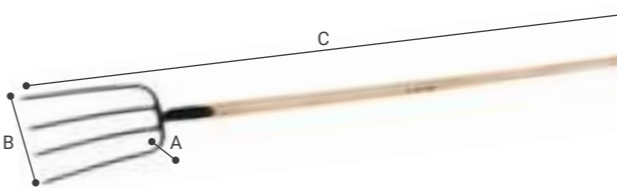

▶ LONG HANDLE FORK 901-4MC SB

REF.	€	g	A mm	B mm	C mm	L mm		
9014MCSB	35,33	671261	2	1.600	190	201	1.647	32



▶ MANURE FORK 901-5

REF.	€	g	A mm	B mm	C mm	L mm	M	
901-5	25,21	156201	12	1.010	250	470	34	M901LR120 M901LC135 M901AC75 M901LR120SB

For hay and manure collecting.



▶ MANURE FORK 901-6

REF.	€	g	A mm	B mm	C mm	L mm	M
901-6	34,57	156218	12	1.350	240	310	450 35
M901LR120 M901LC135 M901AC75 M901LR120SB							

For hay and manure collecting.



▶ LONG HANDLE FORK 901-6MC SB

REF.	€	g	A mm	B mm	C mm	L mm	M
9016MCSB	49,62	671322	2	1.600	220	310	1.650 35



▶ GARDEN FORK WITH D-HANDLE 902-3

REF.	€	g	A mm	B mm	C mm	L mm	M
902-4 MA	50,33	156164	2	1.925	180	230	1.180 32
M902AC75							



▶ GARDEN FORK WITH D-HANDLE 902-5

REF.	€	g	A mm	B mm	C mm	L mm	M
902-5 MA	58,62	156171	2	1.920	140	260	1.220 34
M902AC75							

For hay and manure collecting.



▶ GARDEN FORK WITH D-HANDLE 902-6

REF.	€	g	A mm	B mm	C mm	L mm	M
902-6 MA	63,49	156188	2	2.500	130	350	1.235 35
M902AC75							

For hay and manure collecting. For light material transferring.

FORK STONE AND SHOVEL

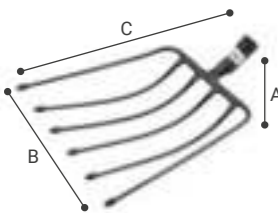

▶ FORK STONE AND GRAVEL 904-6

REF.	€	g	A mm	B mm	C mm	L mm	M
904-6	49,70	156256	12	1.550	70	280	445 36
M901LR120 M901LC135 M901AC75 M901LR120SB							

For stone and gravel.



▶ LONG HANDLE FORK 904-6MC SB

REF.	€	g	A mm	B mm	C mm	L mm	M
9046MCSB	66,23	671353	2	1.600	70	280	1.650



▶ STONE AND GRAVEL FORK WITH D-HANDLE 905-9

REF.	€	g	A mm	B mm	C mm	L mm	M
905-9 MA	90,96	156195	2	3.150	180	260	1.260 35
M901LR120 M901LC135 M901AC75 M901LR120SB							

For stone and gravel.

GARDEN FORKS

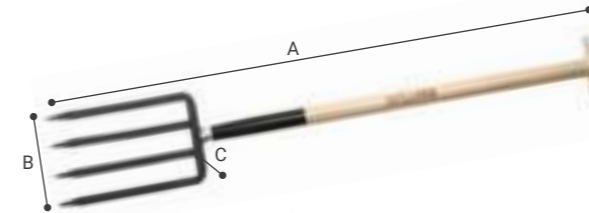

▶ GARDEN FORK WITH LONG HANDLE 911-4

REF.	€	g	A mm	B mm	C mm	L mm	M
911-4 MM	46,33	639131	2	1.850	1.165	188	50 27
M901LR120 M901LC135 M902AC75 M901LR120SB							

For turning the soil, taking out crops, areating and breaking up compact soils.



▶ GARDEN FORK WITH T-HANDLE 905-9

REF.	€	g	A mm	B mm	C mm	L mm	M
911-4 MA	51,42	156270	2	1.980	55	190	1.220 27
M901LR120 M901LC135 M902AC75 M901LR120SB							

For turning the soil, taking out crops, areating and breaking up compact soils.



▶ GARDEN FORK WITH D-HANDLE 911-4

REF.	€	g	A mm	B mm	C mm	L mm	M
911-4 ML	46,77	375428	2	2.150	70	180	1.465 27
M901LR120 M901LC135 M902AC75 M901LR120SB							

For turning the soil, taking out crops, areating and breaking up compact soils.



▶ GARDEN FORK 910-4

REF.	€	g	A mm	B mm	C mm	L mm	M
910-4	33,87	156263	12	1.210	40	195	405 27
M901LR120 M901LC135 M901AC75 M901LR120SB							

For turning the soil, taking out crops, areating and breaking up compact soils.

HAY RAKE

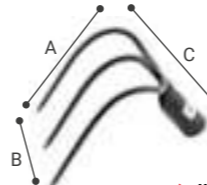

▶ HAY RAKE 903-3

REF.	€	g	A mm	B mm	C mm	L mm	M
903-3	22,55	156225	12	520	240	180	175 21
M901LR120 M901LC135 M901AC75 M901LR120SB							

For burden ripper.



▶ HAY RAKE 903-4

REF.	€	g	A mm	B mm	C mm	L mm	M
903-4	22,94	156287	12	790	210	210	250 21
M901LR120 M901LC135 M901AC75 M901LR120SB							

For burden ripper.



▶ HAY RAKE 903-5

REF.	€	g	A mm	B mm	C mm	L mm	M
903-5	27,87	156232	12	900	210	240	250 21
M901LR120 M901LC135 M901AC75 M901LR120SB							

For burden ripper.



▶ HAY RAKE 903-6

REF.	€	g	A mm	B mm	C mm	L mm	M
903-6	34,24	156249	12	980	210	225	260 21
M901LR120 M901LC135 M901AC75 M901LR120SB							

For burden ripper.

RAKES AND BROOMS

RAKES

- Manufactured with Special Bellota Steel.
- Three heads adapted to different intensities of work.
 - High intensity: steel head with temper 3+ for a longer tool life: doesn't break, warp or wear away.
 - Medium intensity: steel head with robust design: high resistance.
 - Domestic use: steel head reduced dimensions, lighter for easy handling.
- Two types of handles:
 - Varnished wooden handles, light and comfortable touch. FSC® certified.
 - Hollow fiberglass handles with two grips for a Fetter hold.

Uses:

- For clearing, levelling and preparing soil and covering seeds.

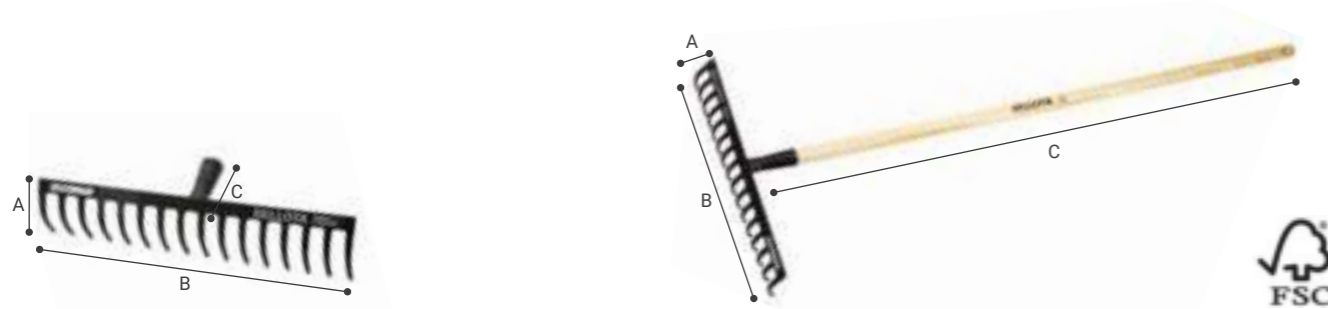

► HIGH INTENSITY RAKE 950

REF.	€	8 41 4299	g	A mm	B mm	C mm	M
950-12	12,72	157819	12	520	100	320	M952 M952L M952LSB
950-14	13,54	157802	12	610	120	375	M952 M952L M952LSB
950-16	14,45	157796	12	650	100	430	M952 M952L M952LSB
950-18	15,99	157789	12	740	100	490	M952 M952L M952LSB

► HIGH INTENSITY RAKE WITH HANDLE 950

REF.	€	8 41 4299	g	A mm	B mm	C mm	M	
950-12 CML	22,37	667387	2	1.010	100	320	1.520	M952 M952L M952LSB
950-14 CML	23,27	667424	2	1.000	100	375	1.520	M952 M952L M952LSB M952SB
950-16 CML	24,02	667349	2	1.160	100	430	1.550	M952 M952L M952LSB M952SB
950-18 CML	25,58	667462	2	1.120	100	480	1.550	M952 M952L M952LSB M952SB



► MEDIUM INTENSITY RAKE 951

REF.	€	8 41 4299	g	A mm	B mm	C mm	M	
951-10	8,63	157765	12	480	100	265	95	M952 M952L M952LSB
951-12	8,85	157758	12	540	100	320	95	M952 M952L M952LSB
951-14	9,28	157741	12	610	125	375	80	M952 M952L M952LSB
951-16	10,03	157734	12	680	100	430	199	M952 M952L M952LSB
951-18	10,53	157727	12	800	100	490	95	M952 M952L M952LSB
951-20	12,07	157710	12	820	100	545	95	M952 M952L M952LSB



► MEDIUM INTENSITY RAKE WITH HANDLE 951

REF.	€	8 41 4299	g	A mm	B mm	C mm	M	
951-10 CML	18,30	667509	2	1.030	100	260	1.550	M952 M952L M952LSB M952SB
951-12 CML	18,71	667547	2	1.070	100	320	1.550	M952 M952L M952LSB M952SB
951-14 CML	18,59	667585	2	1.080	100	425	1.550	M952 M952L M952LSB M952SB
951-16 CML	19,35	667622	2	1.280	100	430	1.520	M952 M952L M952LSB M952SB
951-18 CML	20,58	667660	2	1.385	100	490	1.520	M952 M952L M952LSB M952SB
951-20 CML	21,73	667707	2	1.440	100	545	1.520	M952 M952L M952LSB M952SB



► DOMESTIC USE RAKE 952

REF.	€	8 41 4299	g	A mm	B mm	C mm	M	
952-12	6,98	157703	12	370	100	270	75	M952 M952L M952LSB
952-14	7,04	157697	12	420	100	320	75	M952 M952L M952LSB
952-16	7,72	157680	12	470	125	370	60	M952 M952L M952LSB



► DOMESTIC USE RAKE WITH HANDLE 952

REF.	€	8 41 4299	g	A mm	B mm	C mm	M	
952-12 CML	16,57	667745	2	910	75	320	1.540	M952 M952L M952LSB M952SB
952-14 CML	16,92	667783	2	860	100	320	1.540	M952 M952L M952LSB M952SB
952-16 CML	17,59	667820	2	1.055	100	370	1.520	M952 M952L M952LSB M952SB



► DOMESTIC USE RAKE WITH FIBERGLASS HANDLE 3102

REF.	€	8 41 4299	g	A mm	B mm	C mm	M	
3102-14 MFVL	22,02	550689	2	1.300	100	375	1.560	M952 M952L M952LSB
3102-16 MFVL	22,99	550702	2	940	100	430	1.540	M952 M952L M952LSB

BROOMS

- Manufactured with Special Bellota Steel.
- Heat treated prongs for great elasticity and to prevent bending.
- Maximum bending strength prongs.
- Coatings and treatments to prevent rust.
- Two types of handles:
 - Varnished wooden handles, light and comfortable touch. FSC® certified.
 - Aluminium handles: light and long-lasting. With anti-slip vinyl coating and grips on the upper end for an improved hold.

Uses:

- For lawn cleaning.
- For clearing lawns from grass cuttings or fallen leaves.

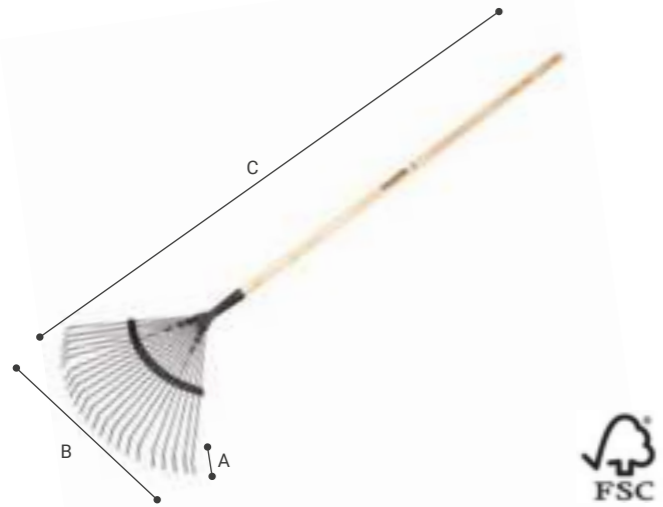

▶ ROUND PRONGS LAWN RAKE 3040

REF.	€	8 41 4299	g	A mm	B mm	C mm	M
3040 CM	22,52	185539	6	870	60	470	M3020 M3020SB
3040	14,24	195095	6	590	27	440	M3020 M3020SB

For graber soil cleaning.



▶ ROUND PRONGS LAWN RAKE WITH ALUMINIUM HANDLE 3040

REF.	€	8 41 4299	g	A mm	B mm	C mm	M
3040CMA	25,91	652086	2	770	50	410	M3020 M3020SB

For graber soil cleaning.



▶ FLAT PRONGS LAWN RAKE 3041

REF.	€	8 41 4299	g	A mm	B mm	C mm	M
3041 CM	21,73	159417	6	900	25	400	1.580 M3020 M3020SB
3041	14,30	159639	12	440	30	385	420 M3020 M3020SB

For grass, leaves or waste clearing without damaging the lawn.



▶ FLAT PRONGS ADJUSTABLE LAWN RAKE WITH ALUMINIUM HANDLE 3042

REF.	€	8 41 4299	g	A mm	B mm	C mm	M
3042 CMA	30,61	533743	6	830	40	390	1.570 M3020 M3020SB

Adjustable Width 385mm-480 mm.



▶ FLAT PRONGS LAWN RAKE WITH ALUMINIUM HANDLE 3041

REF.	€	8 41 4299	g	A mm	B mm	C mm	M
3041 CMA	26,28	533729	6	770	50	410	1.560 M3020 M3020SB

For grass, leaves or waste clearing without damaging the lawn.



▶ FLAT PRONGS ADJUSTABLE LAWN RAKE 3042

REF.	€	8 41 4299	g	A mm	B mm	C mm	M
3042 CM	26,28	159424	6	960	25	400	1.570 M3020 M3020SB
3042	18,92	159646	12	520	40	385	425 M3020 M3020SB

Working Width 385 mm-480 mm.

PLASTIC BROOMS



▶ PLASTIC LAWN RAKE 3034-24

REF.	€	8 41 4299	g	A mm	B mm	C mm	M
3034-24 CM	23,51	611410	6	850	55	630	1.810 M3020 M3020SB
3034-24	16,05	577471	6	420	40	620	500 M3020 M3020SB

Working width 620 mm.



▶ PLASTIC LAWN RAKE 3034-32

REF.	€	8 41 4299	g	A mm	B mm	C mm	M
3034-32 CM	27,76	611458	6	1.070	85	840	2.000 M3020 M3020SB
3034-32	18,48	611434	6	700	40	820	690 M3020 M3020SB

Working width 820 mm.



▶ PLASTIC BROOM 3035

REF.	€	8 41 4299	g	A mm	B mm	C mm	M
303513	4,00	048681	6	120	61	250	197 M3035
303523	8,00	048728	6	310	66	499	272 M3035
303535	11,90	048766	6	570	95	778	310 M3035

NEW



▶ ALUMINIUM HANDLE PLASTIC BROOMS M 3035

REF.	€	8 41 4299	g	A mm	B mm	C mm	M
M 3035	13,5	52978	6	470	30	30	1614 303513 303523 303535

NEW

0% CHEMICALS RANGE

1

► **We've adapted to the new regulations:**

We are committed to designing the tools that meet your actual needs and make your day-to-day activities easier.

2

► **Designed to last:**

- The diamond hoe and the weeding hoes are forged, making them extremely durable and long-lasting tools.
- Oscillating hoes have a tempered, sharp blade to easily and efficiently remove weeds.

3

► **Committed to the environment:**

- With these tools, besides taking care of your land and your plants, you'll help the environment, since you won't need to use chemical products to eliminate weeds.
- Our handles are made of beech wood and have PEFC certification.

WE HELP YOU CHOOSE YOUR TOOL:



	DIAMOND HOE	WEEDING HOE	OSCILLATING HOE 10	OSCILLATING HOE 13
For precision and detail	▲		▲	
For hard-to-reach areas	▲		▲	
To remove moss	▲	▲		
To remove fibrous weeds		▲		
To remove light/surface weeds	▲		▲	▲
To clean up pavement joints	▲			
To remove weeds in compacted soil (roads, unpaved areas, granitic sand, packed crushed rock, gutters, etc.)	▲	▲		
To remove weeds in soft soil (vegetable gardens, landscaped gardens, etc.)			▲	▲

KEEP YOUR SOIL CLEAN AND ELIMINATE WEEDS WITHOUT THE USE OF CHEMICALS.

% CHEMICALS RANGE

PHYTO 0% LONG HANDLE TOOLS

Diamond hoe:

- Removes weeds with precision and detail.
- Easy finishing for hard-to-reach areas.
- Cleans moss and scum in hard-to-reach areas.
- With a 20cm head.
- PEFC-certified handle length: 1,500mm.

Weeding hoe:

- The sharp notched blade removes the densest weeds.
- Push and pull work.
- With a 17.5cm head.
- PEFC-certified handle length: 1,500mm.

Oscillating hoe:

- Hoe swings back and forth to remove weeds on the surface.
- Sharp blade.
- Two blade sizes:
 - LHT308610W1500 OSCILLATING HOE- 10cm
 - LHT308612W1500 OSCILLATING HOE- 12cm
- PEFC-certified handle length: 1,500mm.

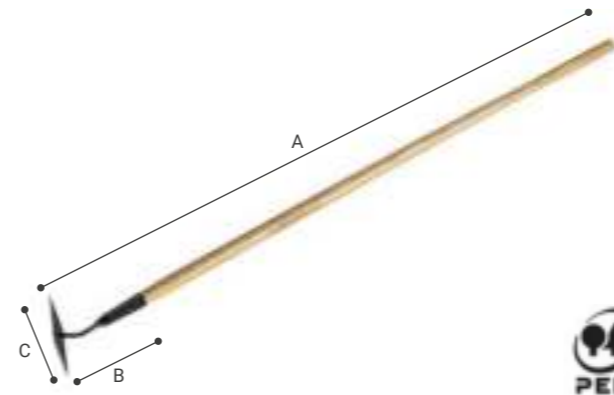

► **DIAMOND HOE**

REF.	€	8 41 4299	g	A mm	B mm	C mm	M
LHT3085W1500	19,78	705577	2	1.120	1.630	200	110 LHT3085 M3085



► **OSCILLATING HOE - 10CM**

REF.	€	8 41 4299	g	A mm	B mm	C mm	M
LHT308610W1500	18,43	705638	2	1.240	1.690	100	140 LHT308610 M3085



► **OSCILLATING HOE - 13CM**

REF.	€	8 41 4299	g	A mm	B mm	C mm	M
LHT308612W1500	19,78	705676	2	1.270	1.690	130	140 LHT308612 M3085



► **WEEDING HOE - 18CM**

REF.	€	8 41 4299	g	A mm	B mm	C mm	M
LHT3087W1500	25,78	705737	2	1.310	1.660	180	70 LHT3087 M3087

TOOLS FOR YOUR ORCHARD

LONG WOODEN HANDLE TOOLS

- Special steel and very lights tools.
- Special coating to prevent tool breakage.
- Varnished wooden handles, light and comfortable touch. length 1,500 mm. PEFC certified.
- Handles with variable diameter to Fetter fit different hand sizes.

Uses:

- For garden and vegetable tasks.
- For clearing, aerating, breaking clods and planting.

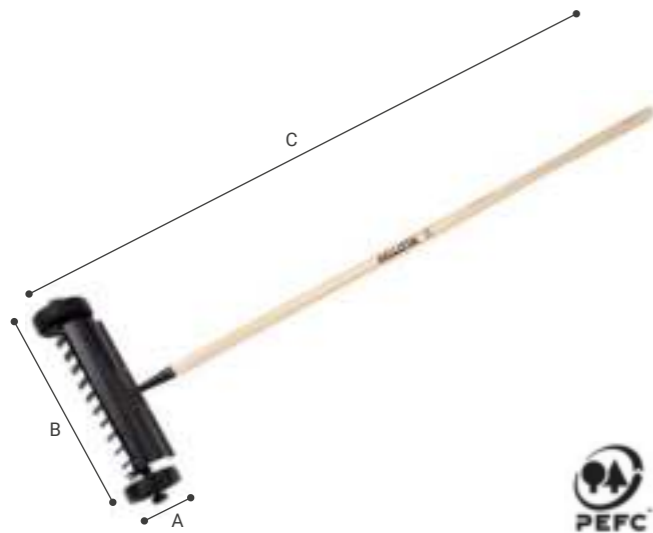

► **WHEELED SCARIFIER 3080**

REF.	€	8 41 4299	g	A mm	B mm	C mm
3080 CM	40,69	612301	1	2.400	150	520
3080	33,14	612271	1	1.650	140	180

For Spring and Autumn lawn conditioning. Spring: cleaning and moss and other waste removal. Autumn: preparing the lawn for vegetation recovery period.



► **TILLING HOE 3081**

REF.	€	8 41 4299	g	A mm	B mm	C mm
3081 CM	18,73	609912	6	1.240	150	250
3081	9,83	609899	6	360	100	155

For weeding and breaking the soil.



► **PEAK HOE 3082**

REF.	€	8 41 4299	g	A mm	B mm	C mm
3082 CM	18,80	609950	6	1.060	120	1.590
3082	8,79	609936	6	280	100	180

Multi-purpose: digging, furrow closing, weeding and preparing the soil for sowing.



► **ROOT-CUTTING HOE 3083**

REF.	€	8 41 4299	g	A mm	B mm	C mm
3083 CM	18,80	609998	6	1.070	80	150
3083	8,79	609974	6	200	65	170

For root cutting. Two sides cutting: push and pull.



► **3 PRONGS CULTIVATOR 3084**

REF.	€	8 41 4299	g	A mm	B mm	C mm
3084 CM	17,00	610031	6	1.010	80	120
3084	7,20	610017	6	210	80	125

For scratching and aerating the soil. Weeding.

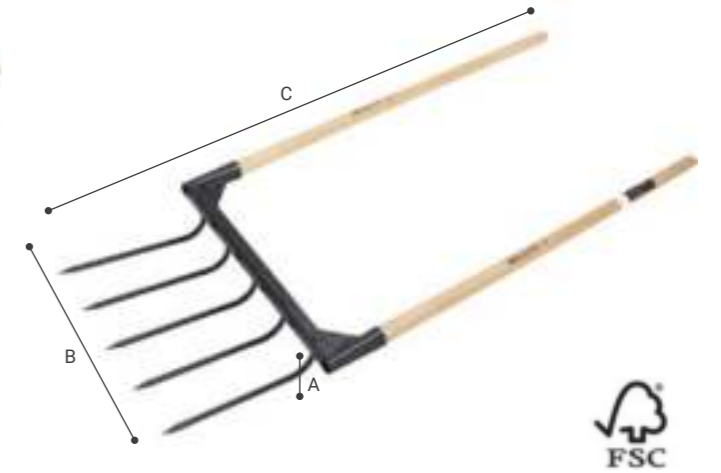

► **ECO FORK 914-5 ECO**

REF.	€	8 41 4299	g	A mm	B mm	C mm	C mm
914-5 ECO	102,99	633184	1	4.150	110	530	1.420
						42	

For breaking and aerating the soil without turning it out, in order to preserve microbiological layers of the topsoil. This allows to respect beneficial microorganisms which turn organic matter into natural fertilizer. To use in worked and broken grounds.

SHORT HANDLE TOOLS: FIBERGLASS

- Manufactured with fiberglass: light and strong.
- Optimized designs for easy working.
- Easy to clean.

Uses:

- Small tools for tasks on terraces, flower pots, rock gardens and balconies.

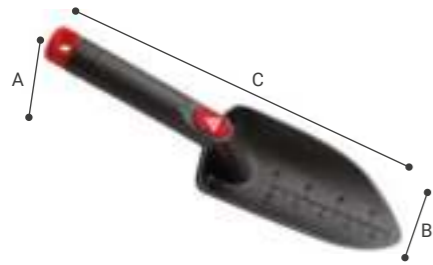

► TROWEL 2985

REF.	€	8 41 4299	g	A mm	B mm	C mm
2985	4,51	168006	6	120	40	85

For transplanting. Working width 85 mm.



► NARROW TROWEL 2986

REF.	€	8 41 4299	g	A mm	B mm	C mm
2986	4,51	169614	6	100	40	60

For transplanting. Working width 60 mm.



► RAKE 2987

REF.	€	8 41 4299	g	A mm	B mm	C mm
2987	4,51	169669	6	99	45	85

For turning and aereating the soil.



► FORK-HOE 2990

REF.	€	8 41 4299	g	A mm	B mm	C mm
2990	6,55	169812	6	160	75	210

For turning and aereating the soil.



► TOOL KIT 2994

REF.	€	8 41 4299	g	A mm	B mm	C mm
2994	15,56	577341	4	630	70	255

Perfect for basic gardening tasks. Good gift idea.



► HORI HORI HMC3000S

REF.	€	8 41 4299	g	A mm	B mm	C mm
HMC3000S	14,00	026092	1	270	326	70

SHORT HANDLE TOOLS: ALUMINIUM

- Manufactured in one single aluminium piece: light and strong.
- Special design: improved performance and easy to handle.
- Two-material handles with SOFT TOUCH for comfort during work.

Uses:

- Small tools for tasks on terraces, flower pots, rock gardens and balconies.



► TROWEL 3001

REF.	€	8 41 4299	g	A mm	B mm	C mm
3001	8,67	159493	6	200	30	80

For transplanting. Working width 80 mm.



► NARROW TROWEL 3000

REF.	€	8 41 4299	g	A mm	B mm	C mm
3000	8,82	170306	6	190	50	60

For transplanting. Working width 60 mm.



► RAKE 2998

REF.	€	8 41 4299	g	A mm	B mm	C mm
2998	9,00	170122	6	261	40	80

For turning and aereating the soil.



► FORK-HOE 3005

REF.	€	8 41 4299	g	A mm	B mm	C mm
3005	9,30	159530	6	370	50	200

For breaking and aereating the soil.



► RAKE 3006

REF.	€	8 41 4299	g	A mm	B mm	C mm
3006	8,92	159547	6	280	60	110

For clearing, levelling and covering seeds.



► DIBBER 3003

REF.	€	8 41 4299	g	A mm	B mm	C mm
3003	8,57	159516	6	180	32	120

For planting bulbs and seedlings.



► HANDHELD BULB PLANTER 3012

REF.	€	8 41 4299	g	A mm	B mm	C mm
3012	7,99	169966	6	250	75	120

For planting bulbs and seedlings up to 6cm diameter.



► TOOL KIT 3076

REF.	€	8 41 4299	g	A mm	B mm	C mm
3076	30,83	561937	4	1.200	65	260

Perfect for basic gardening tasks. Good gift idea.

CORDLESS PRUNING SHEARS

1

► **Ergonomic:**

Their design adapts very well to your hand and the normal movements between branches. You don't have to adopt any uncomfortable postures, so your hands, arms and back will thank you for it.

2

► **Freedom of movement:**

Cordless and without a backpack, you will have complete freedom of movement between branches.

3

► **Light:**

They are light and compact machines, which make your work comfortable, but not tiring.

WITH THE NEW BELLOTA POWER TOOL RANGE:

YOU WILL OPTIMIZE WORK TIME

YOU WILL GET BETTER RESULTS

IT WILL REQUIRE LESS EFFORT

NEW

O-LED DISPLAY WITH INDICATORS

- % OF BATTERY
- CUTTING HISTORY
- Nº OF CURRENT CUTS
- ERROR CODE

POWER CUT

BI-MATERIAL HANDLE WITH A LARGER ELASTOMER SURFACE TO AVOID UNPLEASANT BUMPS IN THE HAND.

DOUBLE OPENING-CUTTING CAPACITY:

EPR233P
EPR233P2B
EPR233P3B Ø 20MM A 33 MM

OPTION OF PROGRESSIVE / IMPULSE CUTTING WITH QUICK CHANGE: 1 SECOND

ONE PIECE FORGED BLADE FOR INCREASED DURABILITY.

ANTI-CUTTING SAFETY SYSTEM.

IMPROVED GREASE BOLT THAT KEEPS THE ENTIRE MECHANISM GREASED.

ON/OFF BUTTON + ACTIVATES THE VARIOUS FUNCTIONS.

EPR233P
EPR233P2B
EPR233P3B WEIGHT WITH BATTERY: 950 GR.
WEIGHT WITHOUT BATTERY: 710 GR.

EPR238P
EPR238P2B
EPR238P3B WEIGHT WITH BATTERY: 1.235 GR.
WEIGHT WITHOUT BATTERY: 890 GR

Ref. EPR233P

NEW SYSTEM POWER CUT

Improves performance and efficiency.



► **PRUNING SHEARS COMPARISON**



EPR123P



EPR233P / EPR233P2B / EPR233P3B



EPR238P / EPR238P2B / EPR238P3B

Maximum cutting capacity	Ø 23 mm	Ø 33 mm	Ø 38 mm
Cutting capacity	Ø 16 mm / 23 mm	Ø 20 mm / 33 mm	Ø 22 mm / 38 mm
Type of cutting	Progressive cutting or Cut by impulse	Progressive / impulse cutting with quick change 1s	Progressive / impulse cutting with quick change 1s
Cutting prevention	Cutting prevention system	Cutting prevention system	Progressive / impulse cutting with quick change 1s
Pruning shear weight (with battery)	880 gr	950 gr	1.235 gr
Pruning shear weight (without battery)	690 gr	710 gr	890 gr
Battery weight	190 gr	238 gr	350 gr
Maximum power	400 W	500 W	800 W
Motor	Brushless	Brushless	Brushless
Working temperature	-10°C to +60°C	-10°C to +60°C	-10°C to +60°C
Maximum voltage	10,8 V	16,8 V	25.2 V
Battery	Lithium	Lithium	Lithium
Rated voltage	10,8 V	14,4 V	21.6 V
Amperage or capacity	2.5 Ah	2.5 Ah	2.5 Ah
Autonomy per battery	2,5-4,5 h / 4.000 cuts (depending on Ø and branch hardness)	2-2,5 h / 4.000 cuts (depending on Ø and branch hardness)	3-5 h / 4.000 cuts (depending on Ø and branch hardness)
Charging time	1-2,5 h	2-2,5 h	2-2,5 h
Warranty	Pruning shears: 1 year Battery: 1 year	Pruning shears: 1 year Battery: 1 year	Pruning shears: 1 year Battery: 1 year

► **BATTERY-POWERED CHAINSAW**

ECS1100P



Chainsaw weight (with battery)	1.800 gr
Chainsaw weight (without battery)	1.300 gr
Battery weight	490 gr
Battery type	Lithium
Rated voltage	24 V
Amperage or capacity	4.2 Ah
Approx. battery life	Depends on use
Charge time per battery	2-2,5 h
Warranty	Chainsaw: 1 year. Battery: 1 year
Nominal power	470 W
Motor	Brushless
Working temperature	-10°C to +60°C
Maximum voltage	25.2 V
Maximum cutting capacity	Ø 110 mm
Chain speed	Ø 11 m/s
Guide	4,5" (110mm). Slot 0,043" 1,1 mm
Chainsaw chain	38 1/4 links " (6,35)
Chain sprocket	7
Chain lubrication	Self-adjustable oil pump
Charging voltage	CA 110V-220V
Oil tank capacity	100 ml
Screen	5 digits for item reference Percentage of battery remaining Operating time
Drive system	3 buttons must be pressed to start up the chain

PRUNING AT HEIGHT

► CHAINSAW POLE

ECSP1210P



Pruning shear weight (with battery)	3.750 gr.
Pruning shear weight (without battery)	3.000 gr.
Battery weight	750 gr.
Weight with battery	1.767-2.570 x 200 x 56 mm
Weight without battery	1.767-2.570 x 88 x 56 mm
Battery	Lithium
Maximum voltage	25.2 V
Rated voltage	21.6 V
Amperage or capacity	5 Ah
Power	108 Wh
Approx. operating time per battery	Depending on ø and branch hardness
Charge time per battery	1-2,5 h
Warranty	Battery: 1 year Battery: 1 year
Maximum voltage	25.2 V
Maximum power	550 W
Motor	Brushless
Working temperature	-10°C to +60°C
Maximum cutting capacity	Ø 210 mm
Chain speed	12 m/s
Other functions	Automatic lubrication and extendable pole
Screen	LCD displaying battery percentage
Oil tank capacity	40 ml.
Cutting prevention	Safety button

► PRUNING SHEARS POLE

EPRP140P



Recommended usage	Pruning at height
Pruning shear weight (with battery)	Depending on the battery used
Pruning shear weight (without battery)	2.200 gr.
Battery weight	Depending on the battery used
Weight with battery	1.600 x 90 x 80 mm
Weight without battery	1.600 x 90 x 80 mm
Battery	Lithium
Maximum voltage	25.2 V
Rated voltage	21,6 V
Amperage or capacity	2,5 Ah / 4,2 Ah / 5 Ah
Power	720 W
Approx. operating time per battery	Depending on ø and branch hardness
Warranty	Pruning shears: 1 year Battery: 1 year
Maximum voltage	25.2 V
Potência máxima	720 W
Motor	Brushless
Working temperature	-10°C to +60°C
Maximum cutting capacity	Ø 40 mm
Cutting speed	1,5 s
Other functions	Automatic lubrication and extendable pole
Screen	-

► ELECTRIC TYING MACHINE

ETY125P



Tying machine weight (with battery)	1.215 gr.
Tying machine weight (without battery)	897 gr.
Battery weight	228 gr.
Battery	Lithium
Rated voltage	14.4 V
Amperage or capacity	2.5 Ah
Autonomy per battery	3-4 h / 5.500 knots
Charging time	2-2,5 h
Warranty	Tying machine: 1 year Battery: 1 year
Maximum power	500 W
Motor	Brushless
Work temperature	-10°C to + 60°C
Maximum voltage	16.8 V
Tying diameter	Ø 25 mm
Tied	Position 1: 3 twists Position 2: 4 twists Position 3: 5 twists Position 4: 6 twists
Tying speed	Speed: 0,3 s.

► BATTERIES

ECBAEPR123P

Maximum voltage	12,6 V
Rated voltage	10,8 V
Amperage	2,5 Ah
Power	27 Wh
Weight	190 gr.

ECBAEPR132P

Maximum voltage	16,8 V
Rated voltage	14,4 V
Amperage	2,5 Ah
Power	36 Wh
Weight	238 gr.

ECBAEPR137P

Maximum voltage	25,2 V
Rated voltage	21,6 V
Amperage	2,5 Ah
Power	54 Wh
Weight	350 gr.

ECBAECS1100P

Maximum voltage	25,2 V
Rated voltage	21,6 V
Amperage	4,2 Ah
Power	90,72 Wh
Weight	490 gr.

ECBAETY125P

Maximum voltage	16,8 V
Rated voltage	14,4 V
Amperage	2,5 Ah
Power	36 Wh
Weight	228 gr.

► BATTERIES COMPATIBILITY

EPR123P 14,4 V	EPR233P 14,4 V	ETY125P 14,4 V	EPR238P 21,6V	ECS1100P 21,6V	EPRP140P 21,6 V	ECSP1210P 21,6 V
ECBAEPR123P 10,8V 2,5AH	ECBAEPR132P 14,4V 2,5AH	ECBAETY125P 10,8V 2,5AH	ECBAEPR137P 21,6V 2,5AH	ECBAECS1100P 21,6V 2,5AH		ECBA5AHP 21,6 5AH

FOR
MORE
INFORMATION



CUTTING AND PRUNING

- The cordless electric shears have an adaptable head design, which makes cutting faster and more accurate, thus increasing productivity significantly and favouring the proper healing and sealing of the branch.
- The chainsaw will be your perfect ally, whether for using it alone to prune and clean your trees and woody crops, or for complementing your electric pruner.
- The extendible pole for electric pruner is the perfect accessory for the shears because you will be able to reach the highest branches overhead.
- The tying machine has 4 tying modes, the 1st is for the thickest branches (3 turns) and the 4th for the thinnest branches (6 turns). At Bellota, we are environmentally friendly, which is why the thread that comes with our tying machine is made of biodegradable paper.

Uses:

- Universal pruning: vines, fruit trees and olive trees.

CORDLESS PRUNING SHEARS



► ELECTRIC PRUNING SHEARS EPR123P

REF.	€	8 41 4299	g	L mm	Ø Corte
EPR123P	230,00	015669	1 2	880 290	16-23

Contains: Electric pruning shear SKU. EPR123P, 2 Lithium-ion batteries, 2-way charger, maintenance tools and instruction manual, maintenance tools and instruction manual.



► ELECTRIC PRUNING SHEARS EPR233P / EPR233P2B / EPR233P3B

REF.	€	8 41 4299	g	L mm	Ø Corte
EPR233P	230,00	032949	1 -	710 250	20-33
EPR233P2B	346,70	054118	1 2	950 295	20-33
EPR233P3B	404,49	032925	1 3	950 295	20-33

Case content EPR233P3B: EPR133P3B electric pruning shears, 3 lithium batteries (enough charge for a whole day's work), 3-way charger, maintenance tools, oil dispenser for lubrication, instructions manual. **Case content EPR-233P2B:** EPR233P2B electric pruning shears, 2 lithium batteries, 3-way charger, maintenance tools, oil dispenser for lubrication, instructions manual. **EPR233P:** Contains the electric pruning shear EPR233P without batteries.



► ELECTRIC PRUNING SHEARS / EPR238P2B / EPR238P3B

REF.	€	8 41 4299	g	L mm	Ø Corte
EPR238P	300,00	054101	1 -	890 295	22-38
EPR238P2B	429,29	054071	1 2	1.235 290	22-38
EPR238P3B	504,29	032956	1 3	1.235 295	22-38

Case content EPR238P3B: EPR238P3B electric pruning shears, 3 lithium batteries (enough charge for a whole day's work), 3-way charger, maintenance tools, oil dispenser for lubrication, instructions manual. **Case content EPR-238P2B:** EPR238P2B electric pruning shears, 2 lithium batteries, 3-way charger, maintenance tools, oil dispenser for lubrication, instructions manual. **EPR238P:** Contains the electric pruning shear EPR238P without batteries.

ELECTRIC CHAINSAW



► ELECTRIC CHAINSAW ECST100P / ECST100PS

REF.	€	8 41 4299	g	A mm	B mm	C mm
ECS1100P	556,82	699531	1 3	1.800 450	75	160
ECS1100PS	300,00	713305	1 -	1.300 400	65	160

Case content ECS1100P: Chainsaw ECS1100P, 3 lithium batteries (enough charge for a whole day's work), 3-way charger, maintenance tools, instructions manual, hard-sided case for transport. **ECS1100PS:** Contains electric chainsaw ECS1100PS without batteries.

LIGHT ELECTRIC TYING MACHINE



► LIGHT ELECTRIC TYING MACHINE ETY125P

REF.	€	8 41 4299	g	L mm
ETY125P	473,98	690774	1 3	1.215 300

Case content: ETY125P electric tying machine, 2 lithium batteries, 2-way charger, 3 rolls of tying thread, maintenance tools, instructions manual.

PRUNING AT HEIGHT



► PRUNING SHEARS POLE EPRP140P

REF.	€	8 41 4299	g	L mm
EPRP140P	420,24	708707	1	2.200 1.600

Battery is not included.



► CHAINSAW POLE ECSP1210P

REF.	€	8 41 4299	g	L mm
ECSP1210P	462,06	708691	1	3.750 1.767 - 2.570

Sold with a 5Ah battery.



► POLE FOR THE ELECTRIC SHEARS EPP1EXTP

REF.	€	8 41 4299	g	L mm
EPP1EXTP	168,10	690767	1	1.380 1.570 - 2.200

* It can be used with the two electric pruning shear models Ref. EPR132P/EPR1322BP/EPR137P.

ACCESSORIES ELECTRIC RANGE



▶ EXTENSION CABLE FOR BATTERY ECEC115P

REF.	€	8 41 4299	g	A mm	B mm	C mm	
ECEC115P	52,89	698848	1	200	1.125	65	70



▶ CASE FOR SHEARS ECSEPR1P

REF.	€	8 41 4299	g	A mm	B mm	C mm	
ECSEPR1P	17,64	699494	1	200	440	150	50



▶ CASE FOR CHAINSAW ECECSC1P

REF.	€	8 41 4299	g	A mm	B mm	C mm	
ECECS1P	20,86	699548	1	220	500	170	80



▶ CASE FOR BATTERIES ECSEB1P

REF.	€	8 41 4299	g	A mm	B mm	C mm	
ECSEB1P	9,41	660661	1	80	120	110	80



▶ ELECTRIC CHAINSAW REPLACEMENT PARTS ECS1100P / ECS100PS

REF.	€	8 41 4299	g	A mm	B mm	C mm	
ECCHCS1100P	54,69	703757	1	270	260	170	90



▶ BELT WITH SUSPENDERS FOR CASES ECBOP1P

REF.	€	8 41 4299	g	A mm	B mm	C mm	
ECBEPR1P	33,51	704570	1	200	70	500	40



▶ LITHIUM GREASE WITH APPLICATOR 400 ML GRS6664

REF.	€	8 41 4299	g	A mm	B mm	C mm	
GRS6664	13,04	705942	12	370	70	66	190



▶ GLOVE FOR CHAINSAW

REF.	€	8 41 4299	g	A mm	B mm	C mm	
ECGL1209P	31,11	017014	1	140	125	250	40
ECGL1210P	31,11	017472	1	150	130	260	40
ECGL1211P	31,11	017519	1	160	135	280	40

POWER RANGE REPLACEMENT PARTS

FOR ELECTRIC PRUNING SHEARS EPR123P



▶ ELECTRIC PRUNERS REPLACEMENT PARTS EPR123P

REF.	€	8 41 4299	g	A mm	B mm	C mm	KEY	
SP23EPR123P	22,56	717143	1	40	80	40	5	EPR123P
SP24EPR123P	24,21	717150	1	30	72	25	4	EPR123P
SP27EPR123P	5,24	717167	1	30	24	24	34	EPR123P
ECBAEPR123P	42,41	717259	1	190	85	55	55	EPR123P
ECCHEPR123P	39,58	717242	1	280	130	100	50	ECBAEPR123P

FOR ELECTRIC PRUNING SHEARS EPR233P / EPR233P2B / EPR233P3B



▶ ELECTRIC PRUNERS REPLACEMENT PARTS EPR233P / EPR233P2B / EPR233P3B

REF.	€	8 41 4299	g	A mm	B mm	C mm	KEY	
H233P	45,33	055191	1	84	100	55	15	EPR233/EPR233P2B/EPR233P3B
CH233P	40,00	691092	1	42	78	40	5	EPR233/EPR233P2B/EPR233P3B
SP05EPR233P	4,90	055214	1	35	20	5	5	EPR233/EPR233P2B/EPR233P3B
ECBAEPR132P	64,64	690781	1	340	75	55	55	EPR233/EPR233P2B/EPR233P3B
ECCHEPR132P	52,89	690804	1	250	130	50	50	ECBAEPR132P

FOR ELECTRIC PRUNING SHEARS EPR238P / EPR238P2B / EPR238P3B



▶ ELECTRIC PRUNERS REPLACEMENT PARTS EPR238P / EPR238P2B / EPR238P3B

REF.	€	8 41 4299	g	A mm	B mm	C mm	KEY	
H238P	50,66	056235	1	97	115	45	15	EPR238P/EPR238P2B/EPR238P3B
CH238P	41,33	056426	1	62	97	50	5	EPR238P/EPR238P2B/EPR238P3B
SP05EPR238P	4,90	056471	1	35	20	5	5	EPR238P/EPR238P2B/EPR238P3B
ECBAEPR137P	76,40	690781	1	340	75	55	55	EPR238P/EPR238P2B/EPR238P3B
ECCHEPR137P	64,64	690804	1	250	130	50	50	ECBAECS1100P/ECBAEPR137P/ECBA5AHP

FOR ELECTRIC CHAINSAW ECS1100P / ECS1100PS



ELECTRIC CHAINSAW REPLACEMENT PARTS ECS1100P / ECS1100PS

REF.		€	8 41 4299	g	A mm	B mm	C mm		
SP57ECS1100P	Guide bar	14,85	703665	1	90	190	35	4	ECS1100P / ECS1100PS
SP58ECS1100P	38-link 1/4" chain	20,28	703672	1	50	240	30	4	ECS1100P / ECS1100PS
SP73ECS1100P	Oil tank cap	2,28	703825	1	10	40	40	80	ECS1100P / ECS1100PS
ECBAECS1100P	4th-generation battery	92,67	703740	1	490	80	60	75	ECS1100P / EPR137PR / EPRP140P
ECCHECS1100P	Charger	54,69	703757	1	270	260	170	90	ECBAECS1100P / ECBAEPR137P / ECBA5AHP

FOR CHAINSAW POLE ECSP1210

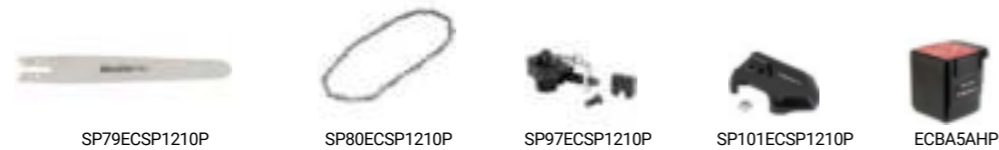

CHAINSAW POLE REPLACEMENT PARTS ECSP1210P

REF.		€	8 41 4299	g	A mm	B mm	C mm		
SP79ECSP1210P	Chain guide plate	23,07	712964	1	150	260	35	4	ECSP1210P
SP80ECSP1210P	48-link chain	28,54	712971	1	70	100	100	10	ECSP1210P
SP99ECSP1210P	Oil can cover assembly	8,37	713152	1	10	60	25	25	ECSP1210P
SP101ECSP1210P	Chain cover assembly	4,00	713176	1	40	100	65	20	ECSP1210P
ECBA5AHP	5Ah 21.6V battery	103,71	708684	1	750	90	90	90	ECSP1210P / EPRP140P

FOR PRUNING SHEARS POLE EPRP140P



CHAINSAW POLE REPLACEMENT PARTS EPRP140P

REF.		€	8 41 4299	g	A mm	B mm	C mm		
SP18EPRP140P	Counter blade for pruning pole	51,99	711431	1	190	180	80	5	EPRP140P
SP19EPRP140P	Special blade for vine pruning	60,16	711462	1	120	115	80	5	EPRP140P
SP23EPRP140P	Splined blade shaft	5,26	711554	1	30	22	22	22	EPRP140P
SP61EPRP140P	Battery protection assembly	11,31	712063	1	60	75	75	75	EPRP140P

FOR ELECTRIC TYING MACHINE ETY125P



TYING MACHINE REPLACEMENT PARTS ETY125P

REF.		€	8 41 4299	g	A mm	B mm	C mm		
ECBAETY125P	14.4V 2.5Ah Lithium-Ion battery pack	51,89	690828	1	228	100	80	70	ETY125P
ECCHETY125P	14.4V two way charger	63,42	691092	1	180	85	50	50	ECBAETY125P
ECTYWPA100P	Paper coil	3,91	690835	1	160	80	80	40	ETY125P

**For more information about spare parts, please contact your local sales representative or SAT BELLOTA.

MANUAL PRUNNERS

PROLINE - SNIPS

- Stainless steel blades with non-stick coating: avoids infection between plants and allows easy maintenance of the shears.
- Blade treatments to prevent breakage and for longer tool life.
- Dual-material ergonomic handles with SOFT TOUCH for comfort during work.
- Integrated shock absorption.
- Spring available as spare part.

Uses:

- For picking grapes, fruit and flowers.

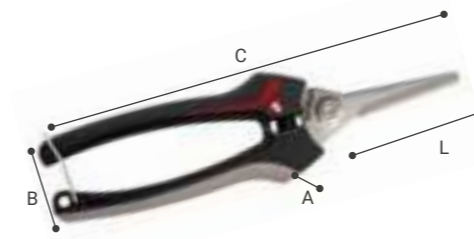

SNIP 3621

REF.	€	8 41 4299	g	A mm	B mm	C mm	L mm	Ø Corte	
3621 INOX-CE MB	9,78	608588	24	90	15	50	180	62	5
3621-C	11,60	623260	6	100	15	50	180	62	5

For fruit, vine and vegetables harvesting.



SNIP 3622

REF.	€	8 41 4299	g	A mm	B mm	C mm	L mm	Ø Corte	
3622 INOX-CE MB	9,78	588255	24	100	15	50	185	62	10
3622-C	11,60	627398	6	100	5	62	185	62	10

Straight and narrow bypass blade. To reach comfortably stems for pruning and clearing.



SNIP 3623

REF.	€	8 41 4299	g	A mm	B mm	C mm	L mm	Ø Corte	
3623 INOX-CE MB	9,78	588231	24	90	15	50	190	60	5
3623-C	11,60	635621	6	90	15	50	185	60	5

Long and narrow blade. For fruit and vine harvesting. For delicate pruning in difficult to reach areas.



SNIP 3624

REF.	€	8 41 4299	g	A mm	B mm	C mm	L mm	Ø Corte	
3624 INOX-CE MB	9,78	588279	24	90	14	50	190	62	5
3624-C	11,60	634921	6	90	15	50	185	62	5

Long and straight blade. For vine harvesting.



SNIP 3625

REF.	€	8 41 4299	g	A mm	B mm	C mm	L mm	Ø Corte	
3625 INOX-CE MB	10,10	588293	24	90	15	50	160	34	5
3625-C	11,60	635645	6	80	19	50	160	34	5

Long and curved blade. For fruit and flower harvesting.



SNIP 3628

REF.	€	8 41 4299	g	A mm	B mm	C mm	L mm	Ø Corte	
3628 INOX-CE MB	9,78	588316	24	90	17	48	172	45	10
3628-C	11,60	626940	6	93	15	50	170	45	10

Small bypass blade. For fruit and vine harvesting and cutting and pruning of small stems.



SNIP 3629

REF.	€	8 41 4299	g	A mm	B mm	C mm	L mm	Ø Corte	
3629INOXGR25MB	9,78	588330	25	100	15	50	200	79	5

Long and curved blade. For fruit and flower harvesting.

PROLINE-PRUNERS

- Easy and clean cut: designed for perfect penetration and gliding of the blade into the branch.
- Blades forged from special Bellota high wear resistant steel to extend the life of the tool.
- EASY ADJUST PATENTED articulation system to guarantee precise, simple and stable shear adjustment over time.
- The handle is ergonomically designed for a perfect fit to the hand and greater transmission of cutting force.
- All spare parts are available.

Uses:

- All purpose pruning: vines, fruit trees and olive trees.

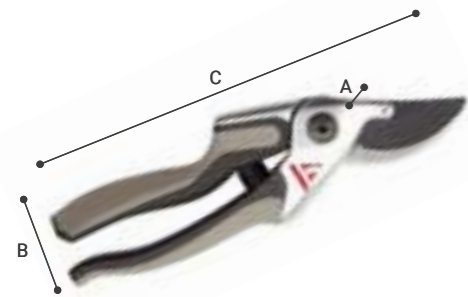

► UNIVERSAL ALUMINIUM HANDLE PRUNER 3510

REF.	€	8 41 4299	g	A mm	B mm	C mm	Ø Corte
3510-21	51,11	549775	3	280	20	60	210 25

Very ergonomic and resistant.



► EASYCUT UNIVERSAL ALUMINIUM HANDLE PRUNER 3512

REF.	€	8 41 4299	g	A mm	B mm	C mm	Ø Corte
3512-21	54,08	576276	3	240	20	55	210 30
3512-22	54,08	576290	3	270	20	55	220 30

Specially designed for big branches pruning.



► SPECIAL FRUIT TREES ALUMINIUM HANDLE PRUNER 3604

REF.	€	8 41 4299	g	A mm	B mm	C mm	Ø Corte
3604-21	46,62	187892	3	255	20	60	220 25

Aluminium handles construction with non-slip covering: light and ergonomic.



► UNIVERSAL FORGED PRUNER 3504-23

REF.	€	8 41 4299	g	A mm	B mm	C mm	Ø Corte
3504-23	43,25	143607	3	470	20	65	230 25

Forged in one single piece, highly robust.



► UNIVERSAL STAMPED STEEL HANDLES PRUNER 3505-23

REF.	€	8 41 4299	g	A mm	B mm	C mm	Ø Corte
3505-23	40,24	341416	3	330	20	55	230 25

Stamped steel light handles.

ONE HAND PRUNING SHEARS FOR GARDEN - SMART

- Non-stick coated cutting blade and counter blade for a clean, effortless cut.
- Slanted cutting head to give a comfortable cutting position to avoid bending the hand.
- Bolt designed for stable and precise adjustment.
- Stable spring that reduces fatigue.

Uses:

- For the care and maintenance of plants and trees in the garden.

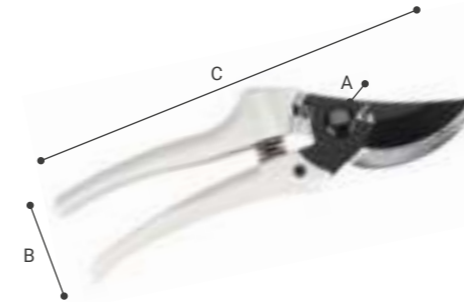

► SMART PRUNER 3408

REF.	€	8 41 4299	g	A mm	B mm	C mm	Ø Corte
3408	11,50	707144	3	188	195	60	25 20



► SMART ERGONOMIC PRUNER 3409

REF.	€	8 41 4299	g	A mm	B mm	C mm	Ø Corte
3409	12,45	707168	3	170	205	65	25 20



► SMART ANVIL PRUNER 3410

REF.	€	8 41 4299	g	A mm	B mm	C mm	Ø Corte
3410	13,00	615654	3	187	195	65	25 20

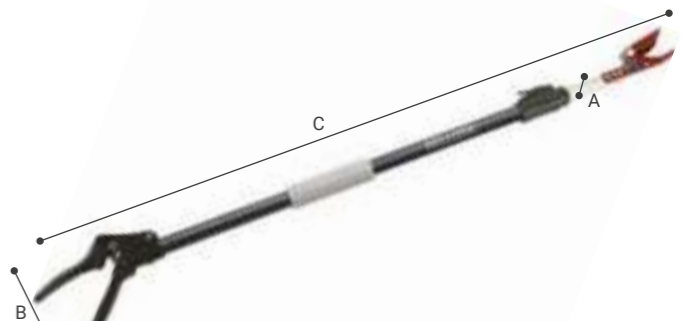

► LONG REACH PRUNER 3612

REF.	€	8 41 4299	g	A mm	B mm	C mm	Ø Corte
3612	67,52	563344	2	820	25	65	1.020 10

Detachable cut'n'hold feature holds stem until you release the grip. Pick and hold system. Extensible.



► FLORAL PRUNER 3520

REF.	€	8 41 4299	g	A mm	B mm	C mm	Ø Corte
3520	14,20	563368	6	110	15	90	205 15

Stainless steel blade. Curved and toothed blade for clean cutting.

CLASSIC LINE - PRUNERS

- Well-designed cutting angles and sharpness for accurate and clean cutting.
- Blade treated to prevent breakage and for a longer tool life.
- Classic robust design.
- Spare parts are available.

Uses:

- For intensive pruning and picking.



► UNIVERSAL FORGED PRUNER 3501

REF.	€	8 41 4299	g	A mm	B mm	C mm	Ø Corte
3501-18	12,15	160024	12	180	16	50	180 20
3501-18 BL	13,44	160444	6	170	20	40	180 20
3501-20	13,93	160086	6	280	20	55	210 22
3501-20 BL	15,70	160451	6	180	15	50	190 22
3501-22	15,71	160093	6	300	21	55	225 25
3501-22 BL	17,51	160468	6	300	20	60	220 25
3501-24	18,29	160109	6	400	21	60	240 25
3501-24 BL	20,31	160475	6	400	22	60	240 25
3501-26	21,15	078206	6	440	22	65	260 25



► HARVESTING FORGED PRUNER 3502

REF.	€	8 41 4299	g	A mm	B mm	C mm	Ø Corte
3502-19	9,93	160116	12	170	14	50	190 25
3502-19 BL	11,60	160482	6	180	15	50	190 25



► FORGED GARLIC PRUNER 3503

REF.	€	8 41 4299	g	A mm	B mm	C mm	Ø Corte
3503-19	12,67	160123	12	180	32	170	375 20
3503-19 BL	13,58	160499	6	180	16	38	200 20

PROLINE - LOPPERS

- Easy and clean cut: perfect penetration and sliding of the cutting blade on the branch.
- Highly resistant Bellota steel cutting blades for a longer tool life.
- EASY ADJUST joint system patented and exclusive to ensure precise, easy and stable system over time.
- EXTRA shock absorber with more surface contact for minimum effort and minimum fatigue.
- Elliptical aluminium handles with SOFT TOUCH grips for comfort during work, light and ergonomics.
- All spare parts are available.

Uses:

- All purpose pruning: vines, fruit trees and olive trees.

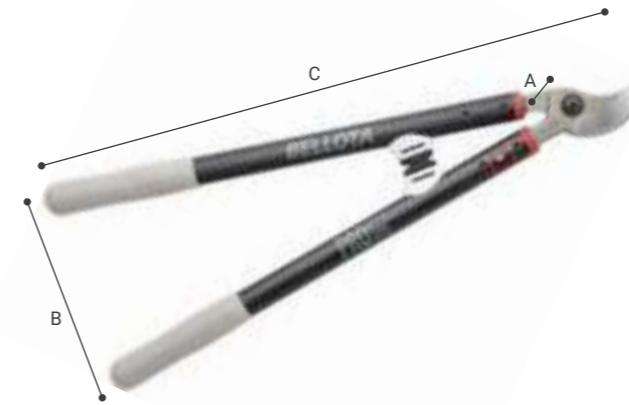

► UNIVERSAL LOPPER 3578

REF.	€	8 41 4299	g	A mm	B mm	C mm	Ø Corte
3578-40	64,96	580112	3	870	32	160	425 35
3578-45	67,69	549812	3	800	35	165	450 35
3578-50	70,49	549836	3	900	33	180	500 35
3578-60	73,24	549850	3	1.010	35	210	600 35
3578-75	75,33	588552	3	1.110	31	250	750 35
3578-90	76,79	567953	3	1.210	33	290	900 35

For all purpose pruning: vine, fruit and olive trees.



► UNIVERSAL EXTENSIBLE HANDLE LOPPER 3578

REF.	€	8 41 4299	g	A mm	B mm	C mm	Ø Corte
3578-TEL	76,73	613513	3	1.220	40	220	620 35

For all purpose pruning: vine, fruit and olive trees. Extendable handle from 60 to 90 cm.



► SPECIAL FRUIT TREES LOPPER 3580

REF.	€	8 41 4299	g	A mm	B mm	C mm	Ø Corte
3580-60	66,00	501292	3	1.080	33	210	600 50
3580-75	67,50	588590	3	950	33	250	750 50
3580-90	68,58	566543	3	1.340	32	290	900 50

For fruit tree pruning. Specially designed for thick branches pruning.



► UNIVERSAL TOOTHED COUNTER-BLADE LIGHT LOPPER 3588

REF.	€	8 41 4299	g	A mm	B mm	C mm	Ø Corte
3588D-50	66,95	579895	3	780	33	180	500 35
3588D-60	69,56	579918	3	850	35	210	600 35
3588D-75	71,56	011616	3	940	35	260	750 35

For all purpose pruning: vine, fruit and olive trees.



▶ VINE LIGHT LOPPER 3589

REF.	€	8 41 4299	g	A mm	B mm	C mm	Ø Corte	
3589-40	62,97	579932	3	700	35	155	415	30
3589-50	68,29	579956	3	720	35	180	500	30

For vine pruning and tipping.



▶ POLE PRUNER 3590

REF.	€	8 41 4299	g	A mm	B mm	C mm	Ø Corte	
3590	73,11	633399	4	1.300	35	110	430	35

For all purpose pruning: vine, fruit and olive trees.



▶ POLE PRUNER 3590

REF.	€	8 41 4299	g	A mm	B mm	C mm	Ø Corte	
3590-S	93,33	633412	4	1.420	35	150	420	35

For all purpose pruning: vine, fruit and olive trees.

PROLINE - HEDGE SHEARS

- Easy and clean cut: perfect penetration and sliding of the cutting blade on the branch.
- Highly resistant steel Bellota cutting blades for a longer tool life.
- Elliptical aluminium handles with SOFT TOUCH grips for comfort during work, light and ergonomics.
- Flexible shock absorber for minimum effort and minimum fatigue.

Uses:

- Pruning and maintenance of bushes and trees.

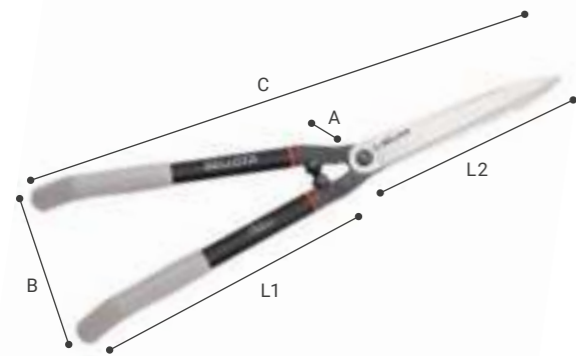

▶ TOOTHED BLADE HEDGE SHEAR 3582

REF.	€	8 41 4299	g	A mm	B mm	C mm	L1 mm	L2 mm
3582	63,37	637472	3	1.170	50	215	690	267

Serrated blade for easy cutting of wet or thick branches and to prevent sliding while cutting.

GARDEN LINE - LOPPERS

- Blade and counter blade have a non-slip coating for clean and easy cut.
- Ergonomic handles, light and balanced reinforced polyamide construction. SOFT TOUCH elastomer grips for comfort during work.
- EXTRA shock absorber with more surface contact for minimum effort and minimum fatigue.
- Bolt designed for precise and stable adjustment.

Uses:

- For pruning thick branches, both green and dry, at different heights.



▶ UNIVESAL LOPPER 3440-75

REF.	€	8 41 4299	g	A mm	B mm	C mm	Ø Corte	
3440-50	49,99	615531	3	890	40	200	510	35
3440-75	55,83	615555	3	1.020	31	270	750	35

Serrated counter blade for a better stability and for an easy cut.



▶ UNIVESAL EXTENDABLE LOPPER 3440

REF.	€	8 41 4299	g	A mm	B mm	C mm	Ø Corte	
3440-TEL	56,63	615517	3	1.130	36	230	610	35

Serrated counter blade for a better stability and for an easy cut. Extendable aluminium handle: 60cm-90 cm.



▶ ANVIL LOPPER 3441

REF.	€	8 41 4299	g	A mm	B mm	C mm	Ø Corte	
3441-75	55,83	622522	3	1.000	30	260	750	45

Aluminium anvil to reduce wear.



▶ EXTENDABLE ANVIL LOPPER 3441

REF.	€	8 41 4299	g	A mm	B mm	C mm	Ø Corte	
3441-TEL	58,33	622546	3	1.180	37	220	620	45

Aluminium anvil to reduce wear. Extendable aluminium handle: 60 cm-90 cm.



▶ POWERCUT X 2 LOPPER 3442

REF.	€	8 41 4299	g	A mm	B mm	C mm	Ø Corte	
3442-75	64,17	622584	3	1.100	30	280	790	35

Compound action system.



▶ POWERCUT X 2 LOPPER 3442

REF.	€	8 41 4299	g	A mm	B mm	C mm	Ø Corte	
3443-75	64,17	622560	3	1.100	30	285	750	35

Compound action system. Aluminium anvil to reduce wear.

GARDEN LINE - HEDGE SHEARS

- Blade and counter blade have a non-slip coating for clean and easy cut.
- Ergonomic handles, light and balanced reinforced polyamide construction. SOFT TOUCH elastomer grips for comfort during work.
- EXTRA shock absorber with more surface contact for minimum effort and minimum fatigue.
- Bolt designed for precise and stable adjustment.

Uses:

- For trimming of hedges and bushes in landscaping.

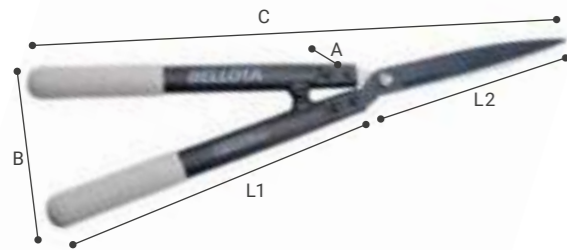

► STRAIGHT BLADE HEDGE SHEAR 3461

REF.	€	8 41 4299	g	A mm	B mm	C mm	L1 mm	L2 mm
3461-R	42,51	615616	3	1.000	30	190	660	645 230

For the cutting of thin branches and hedge and bushes trimming.



► STRAIGHT BLADE HEDGE SHEAR WITH EXTENDABLE HANDLE 3461

REF.	€	8 41 4299	g	A mm	B mm	C mm	L1 mm	L2 mm
3461-R TEL	49,60	635041	3	1.040	37	180	600	800 230

Extendable handles: 60 cm- 80 cm.



► CURVED BLADE HEDGE SHEAR 3461

REF.	€	8 41 4299	g	A mm	B mm	C mm	L1 mm	L2 mm
3461-C	42,51	615630	3	960	30	195	660	645 230

For cutting thick branches and hedges and bushes with scattered branches trimming.

GARDEN LINE - GRASS SHEARS

- Blade and counter blade with non-slip coating for clean and easy cut.
- Ergonomic handles, light and balanced reinforced polyamide construction. SOFT TOUCH elastomer grips for comfort during work.
- Ergonomic handles, light and balanced.

Uses:

- To cut and trim lawns.

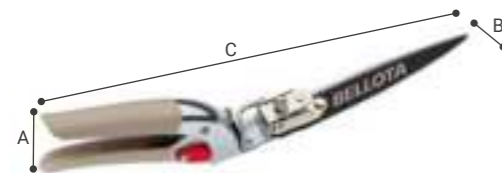

► GRASS SHEAR 3555

REF.	€	8 41 4299	g	A mm	B mm	C mm	L2 mm
3555	19,86	091328	6	410	25	60	340 15

Rotating blade.

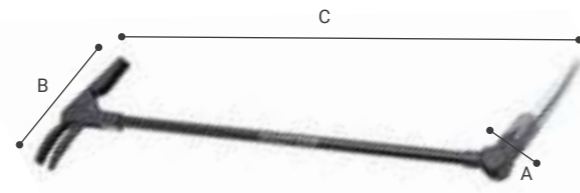

► LONG REACH GRASS SHEAR 3556

REF.	€	8 41 4299	g	A mm	B mm	C mm	L2 mm
3556	44,22	639155	2	1.070	70	270	1.000 14,5

Working height: 90 cm.

SHEARS SPARE PARTS

PROLINE-PRUNERS



► PARTS FOR UNIVERSAL SHEARS 3510

REF.	€	8 41 4299	g	Description	REF.
3510-H	17,50	551228	6	Blade	3510
3510-CH	18,86	551242	6	Counter blade	3510
3510-S	6,62	551280	6	Closing device	3510
3510-MA	10,08	551266	6	Spring + Damper	3510
3510-BT	16,45	551303	6	Bolt + Nut	3510
3510-21 H	10,17	551327	6	Blade handle	3510-21
3510-21 C	10,17	551365	6	Counter blade handle	3510-21
3510-22 H	11,92	551341	6	Blade handle	3510-22
3510-22 C	10,17	551389	6	Counter blade handle	3510-22



► PARTS FOR UNIVERSAL SHEARS 3512

REF.	€	8 41 4299	g	Description	REF.
3512-H	17,50	606294	6	Blade	3512
3512-CH	18,86	606331	6	Counter blade	3512
3512-MA	10,08	606317	6	Spring + Damper	3512
3512-BT	16,45	606270	6	Bolt + Nut	3512
3512-21 H	17,50	606355	6	Blade handle	3512-21
3512-21 CH	18,86	606393	6	Counter blade handle	3512-21
3512-22 H	13,43	017267	6	Blade handle	3512-22
3512-22 CH	13,43	222067	6	Counter blade handle	3512-22



► SPARE PARTS FOR STEEL SHEARS 3505-23

REF.	€	8 41 4299	g	Description	REF.
3505-H	12,50	618754	6	Blade	3505-23
3505-CH	10,58	618730	6	Counter blade	3505-23
3505-BT	19,20	618716	6	Bolt + Nut	3505-23
3505-MA	6,72	618778	6	Spring + Damper	3505-23
3505-S	4,86	618792	6	Closing device	3505-23



► SPARE PARTS FOR FORGED SHEARS 3504-23

REF.	€	8 41 4299	📦		🔪
3504-H	12,50	373080	6	Blade	3504-23
3504-CH	10,58	628043	6	Counter blade	3504-23
3504-S	4,86	628067	6	Closing device	3504-23
3510-BT	16,45	551303	6	Bolt + Nut	3504-23
3505-MA	6,72	618778	6	Spring + Damper	3504-23



► PARTS FOR ALUMINIUM SHEARS 3604

REF.	€	8 41 4299	📦		🔪
3604-21 H	9,29	264395	12	Blade	3604-21
3510-BT	16,45	551303	6	Bolt + Nut	3604-21

SMART-PRUNERS



► PARTS FOR SMART SHEARS

REF.	€	8 41 4299	📦		🔪
3408H	4,12	709926	1	Blade	3408
3408CH	3,61	709940	1	Counter blade	3408
3408M	1,55	709902	1	Spring	3408/3409/3410
3409H	4,12	709964	1	Blade	3409
3409CH	3,61	709988	1	Counter blade	3409
3410H	3,61	710007	1	Blade	3410
3410CH	4,12	717334	1	Counter blade	3410

PROLINE-SNIPS

► PARTS FOR HARVESTING SHEARS

REF.	€	8 41 4299	📦		🔪
3622 INOX-M	0,88	593723	12	Spring + Damper	3621, 3622, 3623, 3624, 3625, 3628, 3629

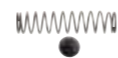

PROLINE-LOPPERS



► PARTS FOR UNIVERSAL PRUNING SHEARS

REF.	€	8 41 4299	📦		🔪
3578-H	23,11	551068	6	Blade	3578, 3578D, 3578 TEL
3578-CH	23,88	551082	6	Counter blade	3578, 3578 TEL
3578-CHD	27,54	551105	6	Serrated counter blade	3578D
3578-A	6,47	551129	6	Set damper	3578, 3578D, 3580, 3588D, 3589
3578-BT	16,45	551143	6	Bolt + Nut	3578, 3578D, 3580, 3588D, 3589
3578-TTM	6,09	135329	6	Set screw for the handle	3578, 3578D, 3580, 3581, 3588D, 3589
3578-M40	31,04	028218	6	Handle	3578, 3578D, 3580
3578-M45	31,04	551167	6	Handle	3578, 3578D, 3580
3578-M50	31,04	551181	6	Handle	3578, 3578D, 3580
3578-M60	31,04	551204	6	Handle	3578, 3578D, 3580
3578-M75	33,90	594959	6	Handle	3578, 3578D, 3580
3578-M90	34,07	231199	6	Handle	3578, 3578D, 3580

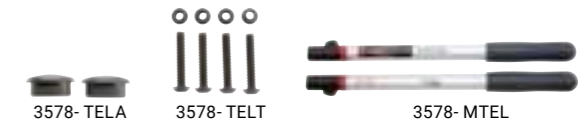

► SPARE PARTS FOR EXTENDIBLE UNIVERSAL SHEARS

REF.	€	8 41 4299	📦		🔪
3578-TELA	6,54	614152	6	Damper	3578-TEL
3578-TELT	6,09	614282	6	Screw	3578-TEL
3578-MTEL	39,88	614138	6	Handles	3578-TEL

► PARTS FOR UNIVERSAL FRUIT PRUNING SHEARS 3580

REF.	€	8 41 4299	📦		🔪
3580-H	23,11	566628	6	Blade	3580
3580-CH	23,88	566642	6	Counter blade	3580



► PARTS FOR ANVIL FRUIT PRUNING SHEARS 3581

REF.	€	8 41 4299	📦		🔪
3581-BM	25,16	593808	6	Multiplier arm	3581
3581-BT	17,35	046601	6	Bolt + Nut + Screw	3581
3581-CH	25,16	593754	6	Counter blade	3581
3581-H	24,32	057713	6	Blade	3581
3581-Y	17,91	593785	6	Aluminium anvil	3581
3581-TA	10,26	360974	6	Screw + Washer + Nut	3581
3581-TTC	8,69	611373	6	Pivot Screw + Washer	3581
3581-M	36,51	593822	6	Handle	3581



* Unit orders for pruning shears spare parts can be placed at a surcharge of 4 % on the marked price.

GARDEN LINE-PRUNERS



► PARTS FOR LIGHTWEIGHT UNIVERSAL PRUNING SHEARS

REF.	€	8 41 4299	📦		🔪
3588-H	22,07	579970	6	Blade	3588D
3588D-CH	22,73	579994	6	Serrated counter blade	3588D
3589-H	23,11	580013	6	Blade	3589
3589-CH	23,88	580037	6	Counter blade	3589
3588-M40	29,46	580051	6	Handle	3588D, 3589
3588-M50	29,46	580075	6	Handle	3588D, 3589
3588-M60	29,46	580099	6	Handle	3588D, 3589
3588-M75	29,46	594973	6	Handle	3588D, 3589



► PARTS FOR POLE 3590

REF.	€	8 41 4299	📦		🔪
3590-H	23,91	633436	4	Blade	
3590-M	9,56	633450	4	Spring	
3590-BT	17,50	633474	4	Bolt + Nut	
3590-C	14,34	633498	4	Rope	
3590-P	6,70	633511	4	Pulley	
3590-A	12,45	633559	4	Clamp	
3590-CH	39,21	633573	4	Set counter blade	

PROLINE-HEDGE SHEARS



► PARTS FOR BUSH TRIMMERS 3584

REF.	€	8 41 4299	📦		🔪
3583-A	3,18	124859	6	Set damper	3584, 3582
3583-T	10,07	125092	6	Screw + Nut	3584, 3582



► PRUNERS

REF.	€	8 41 4299	📦		🔪
3612-H	8,85	084214	1	Blade	3612

GARDEN LINE-LOPPERS



► LOPPERS

REF.	€	8 41 4299	📦		🔪
3440-HT	12,74	627909	6	Blade	3440-50, 3440-75
3440-TEL-HT	12,74	627923	6	Blade	3440-TEL
3441-HT	12,74	627947	6	Blade	3441-50, 3441-75
3441-TEL-HT	12,74	627961	6	Blade	3441-TEL
3440-B	8,85	627985	6	Bolt screw	3440-50, 3440-75, 3440-TEL, 3441-50, 3441-75, 3441-TEL, 3461R
3441-YT	8,85	628029	6	Anvil	3441-50, 3441-75, 3441-TEL
3442-HT	13,80	639056	6	Blade	3442
3443-HT	13,80	639070	6	Blade	3443
3443-YT	8,62	639117	6	Anvil	3443
3578-TELA	6,54	614152	6	Damper	3440, 3441, 3442, 3443, 3461R, 3461C, 3461RTEL, 3461RMM

CLASSIC LINE-PRUNERS

► PARTS FOR FORGED SHEARS

REF.	€	8 41 4299	📦		🔪
R3501-18	1,55	093506	24	Spring	3501-18, 3502-19, 3503-19
R3501-20	1,63	093544	24	Spring	3501-20, 3501-22
R3501-24	1,89	093582	24	Spring	3501-24, 3501,26

ACCESSORIES



► SHARPENER 3642

REF.	€	8 41 4299	📦	g	A mm	B mm	C mm
3642	13,44	091694	12	50	5	15	130

For sharpening any pruning or cutting tools. Tungsten carbide pad.

PRUNING SAWS

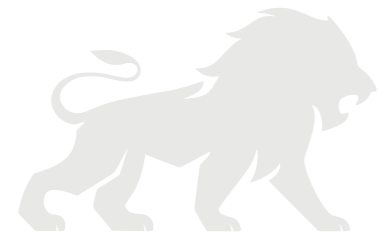

THE CLASSIC CUT RANGE

Specially designed for people who work hard and at a fast pace.

- **Rigid blade** made of special laminated steel and Japanese tothing sharpened on the three sides.
- **Aggressive, traditional cut.**
- Extra-hard tempered teeth.



THE EXPERT CUT RANGE

Specially designed for experienced people who are looking for a clean cut and smooth finish.

- **Flexible blade** made of special laminated steel and Japanese tothing sharpened on the three sides.
- **Fast, smooth and clean cut.**
- Extra-hard tempered teeth.

	CUTTING SPEED	USE INTENSITY	EASY CUTTING	FINE FINISH	FLEXIBLE BLADE	DURABILITY
CLASSIC CUT 	▲▲	▲▲▲	▲▲▲	▲	▲▲	▲▲▲
EXPERT CUT 	▲▲▲	▲▲▲	▲▲	▲▲▲	▲▲▲	▲▲▲

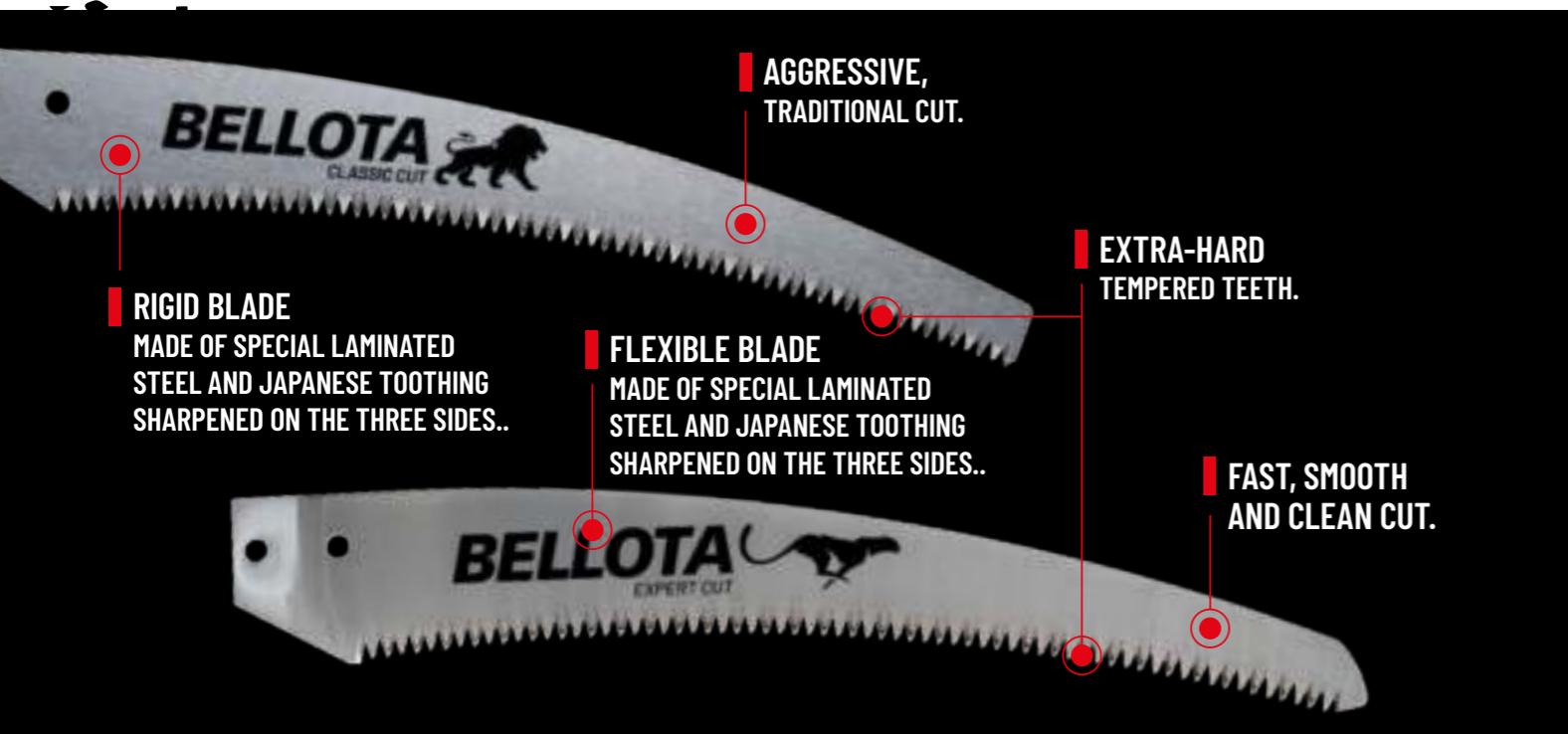

FOR MORE INFORMATION



CUSTOMIZE YOUR SAW IN JUST 3 STEPS

01 CHOOSE YOUR BLADE

▶ CURVED CLASSIC CUT BLADE

For cutting branches above your shoulder.



11 INCHES / 280MM



13 INCHES / 330MM

▶ CURVED EXPERT CUT BLADE

For cutting branches above your shoulder.



11 INCHES / 280MM



13 INCHES / 330MM

▶ STRAIGHT EXPERT CUT BLADE

For cutting branches at your height.



9 INCHES / 228MM



12 INCHES / 304MM

02 CHOOSE YOUR HANDLE

▶ CURVED HANDLE

We have kept the traditional shape, but lengthened the handle to fit your hand.



▶ STRAIGHT HANDLE

For holding the tool more firmly.



03 CHOOSE YOUR SHEATH

▶ CURVED SHEATH

For curved blades.

SAFETY TRIGGER
One-hand release.

AMBIDEXTROUS



QUICK RELEASE BUCKLE AND SWIVEL BUCKLE.

HOLE AT THE END OF THE SHEATH
Large opening to release dirt.

▶ STRAIGHT SHEATH

For straight blades.



QUICK RELEASE BUCKLE AND SWIVEL BUCKLE.

HOLE AT THE END OF THE SHEATH
Large opening to release water.

PRUNING SAWS

PRUNING SAWS



NEW

► LION SAW WITH CURVED BLADE AND CURVED BI-MATERIAL HANDLE 450BIMC

REF.	€	8 41 4299	g	A mm	B mm	C mm	L mm	Nº	
450BIMC11	21,30	028904	6	378	51	123	431	11"	6,4
450BIMC13	22,30	028935	6	395	51	123	481	13"	6,4
450BIMC13SF	15,50	028973	6	268	51	123	478	13"	6,4
H45011	11,04	030846	6	90	1,8	79	314	11"	6,4
H45013	12,33	030860	6	100	1,8	99	364	13"	6,4

* SF: Without sheath



NEW

► LION SAW WITH CURVED BLADE AND STRAIGHT BI-MATERIAL HANDLE 450BIMR

REF.	€	8 41 4299	g	A mm	B mm	C mm	L mm	Nº	
450BIMR11	21,30	028706	6	378	51	123	442	11"	6,4
450BIMR13	22,30	028744	6	395	51	123	492	13"	6,4
450BIMR13SF	15,50	028829	6	268	51	123	489	13"	6,4
H45011	11,04	030846	6	90	1,8	79	314	11"	6,4
H45013	12,33	030860	6	100	1,8	99	364	13"	6,4

* SF: Without sheath



NEW

► LION SAW WITH CURVED BLADE AND CURVED WOODEN HANDLE 450MC

REF.	€	8 41 4299	g	A mm	B mm	C mm	L mm	Nº	
450MC11	19,50	027945	6	348	51	123	431	11"	6,4
450MC13	20,50	028027	6	365	51	123	481	13"	6,4
450MC13SF	15,00	028645	6	238	51	123	478	13"	6,4
H45011	11,04	030846	6	90	1,8	79	314	11"	6,4
H45013	12,33	030860	6	100	1,8	99	364	13"	6,4

* SF: Without sheath



NEW

► LION SAW WITH CURVED BLADE AND STRAIGHT WOODEN HANDLE 450MR

REF.	€	8 41 4299	g	A mm	B mm	C mm	L mm	Nº	
450MR11	19,50	027792	6	348	51	123	442	11"	6,4
450MR13	20,50	027822	6	365	51	123	492	13"	6,4
450MR13SF	15,00	027907	6	238	51	123	489	13"	6,4
H45011	11,04	030846	6	90	1,8	79	314	11"	6,4
H45013	12,33	030860	6	100	1,8	99	364	13"	6,4

* SF: Without sheath



NEW

► CHEETAH SAW WITH CURVED BLADE AND CURVED BI-MATERIAL HANDLE 454BIMC

REF.	€	8 41 4299	g	A mm	B mm	C mm	L mm	Nº	
454BIMC11	22,50	030082	6	368	51	123	431	11"	6,4
454BIMC13	23,50	030136	6	385	51	123	481	13"	6,4
454BIMC13SF	18,40	030174	6	258	51	123	478	13"	6,4
H45411	14,09	030945	6	80	1,3	77	311	11"	6,4
H45413	16,30	031195	6	90	1,3	96	360	13"	6,4

* SF: Without sheath



NEW

► CHEETAH SAW WITH CURVED BLADE AND STRAIGHT BI-MATERIAL HANDLE 454BIMR

REF.	€	8 41 4299	g	A mm	B mm	C mm	L mm	Nº	
454BIMR11	22,50	029499	6	368	51	123	442	11"	6,4
454BIMR13	23,50	029895	6	385	51	123	492	13"	6,4
454BIMR13SF	18,40	029987	6	258	51	123	489	13"	6,4
H45411	14,09	030945	6	80	1,3	77	311	11"	6,4
H45413	16,30	031195	6	90	1,3	96	360	13"	6,4

* SF: Without sheath



NEW

► CHEETAH SAW WITH CURVED BLADE AND CURVED WOODEN HANDLE 454MC

REF.	€	8 41 4299	g	A mm	B mm	C mm	L mm	Nº	
454MC11	21,50	029154	6	338	51	123	431	11"	6,4
454MC13	22,50	029390	6	355	51	123	481	13"	6,4
454MC13SF	17,50	029451	6	228	51	123	478	13"	6,4
H45411	14,09	030945	6	80	1,3	77	311	11"	6,4
H45413	16,30	031195	6	90	1,3	96	360	13"	6,4

* SF: Without sheath



NEW

► CHEETAH SAW WITH CURVED BLADE AND STRAIGHT WOODEN HANDLE 454MR

REF.	€	8 41 4299	g	A mm	B mm	C mm	L mm	Nº	
454MR11	21,50	028997	6	338	51	123	442	11"	6,4
454MR13	22,50	029055	6	355	51	123	492	13"	6,4
454MR13SF	17,50	029093	6	228	51	123	489	13"	6,4
H45411	14,09	030945	6	80	1,3	77	311	11"	6,4
H45413	16,30	031195	6	90	1,3	96	360	13"	6,4

* SF: Without sheath



NEW

► CHEETAH SAW WITH STRAIGHT BLADE AND STRAIGHT BI-MATERIAL HANDLE 45RBIMR

REF.	€	8 41 4299	g	A mm	B mm	C mm	L mm	Nº	
45RBIMR9	23,50	033519	6	352	26	107	415	9"	6,4
45RBIMR12	25,50	030761	6	382	26	107	474	12"	6,4
H45R9	14,09	031249	6	70	1,3	737	292	9"	6,4
H45R12	16,30	031362	6	90	1,3	39	347	12"	6,4

REF.	€	8 41 4299	g	A mm	B mm	C mm	L mm	Nº	
45PBIM7	17,50	030808	6	190	25	60	230	7"	6,1
H45P7	6,60	031522	6	40	1,3	36	211	7"	6,1

Curved blade for easy cutting of difficult to reach branches.



NEW

► CHEETAH SAW WITH STRAIGHT BLADE AND STRAIGHT WOODEN HANDLE 45RMR

REF.	€	8 41 4299	g	A mm	B mm	C mm	L mm	Nº	
45RMR9	22,50	030211	6	322	26	107	415	9"	6,4
45RMR12	24,50	030594	6	352	26	107	474	12"	6,4
H45R9	14,09	031249	6	70	1,3	737	292	9"	6,4
H45R12	16,30	031362	6	90	1,3	39	347	12"	6,4

REF.	€	8 41 4299	g	A mm	B mm	C mm	L mm	Nº	
3011	24,01	089943	6	160	25	60	310	165	3

Conical blade with chrome coating for smooth and fast cutting.



► CURVED PRUNING SAW METAL HANDLE 4587

REF.	€	8 41 4299	g	A mm	B mm	C mm	L mm	Nº	
4587-13 MM	38,10	464092	6	300	27	55	540	13"	6



► CURVED PRUNING SAW METAL HANDLE 3014

REF.	€	8 41 4299	g	A mm	B mm	C mm	L mm	Nº	
3014 HM	32,88	567205	4	450	35	100	600	13"	6

Curved blade for easy cutting of difficult to reach branches.

PRUNING TOOLS

- Manufactured with Special Bellota Steel.
- Japanese teeth sharpened on three sides for easy and clean cutting.
- Double heat treatment for greater performance: fully tempered blade and extra tempered teeth.
- Extendable handle 2,200-3,200 mm for high up pruning locking positions through latches: can be fixed at each position, without gaps.

Uses:

- For pruning woody plants, ornamental plants and trees.
- For high up pruning.

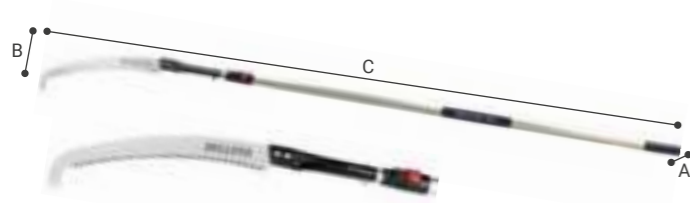

► POLE WITH JAPANESE TEETH CURVED PRUNING SAW P4580

REF.	€	8 41 4299	g	A mm	B mm	C mm	
P4580-13	82,39	582734	3	1.360	50	165	2.260

Extendable from 2,2 m to 3,2 m. Curved saw blade with hook for an easy cutting of high or difficult to reach branches.



► POLE WITH JAPANESE TEETH CURVED PRUNING SAW P4587

REF.	€	8 41 4299	g	A mm	B mm	C mm	
P4587-13	65,89	582758	3	1.330	380	500	2.230

Extendable from 2,2m to 3,2 m. Curved saw blade.



► POLE JAPANESE TEETH CURVED PRUNING SAW 3014

REF.	€	8 41 4299	g	A mm	B mm	C mm	
3014	63,10	563306	6	1.150	50	140	2.090

Japanese teethed pruning saw for easy and clean cutting. Hook on top of the blade for an easy cut of difficult to reach branches.

SPARE PARTS



REF.	€	8 41 4299	g		
3631 M	14,43	124965	1	20	Pruning pole spring 3631
3630	30,69	582772	3	980	Extensible handle P4580-13 / P4587-13 / 3590 / 3590S

BOW SAW BLADES

- Manufactured with Special Bellota Steel.
- High-frequency induction tempered blades for improved teeth durability.
- Perfectly heat treated cutting teeth for maximum strength and performance.
- Stronger cutting blades. Cut straighter, easier and safer.

Uses:

- For cutting branches and wood in general.
- For pruning work and cleaning woody plants mainly fruit trees and bushes.

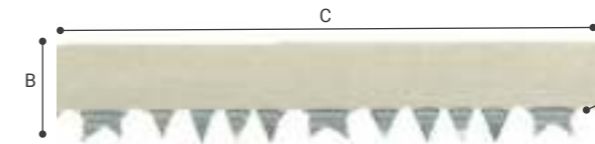

► AMERICAN TEETH BOW BLADE 4535

REF.	€	8 41 4299	g	A mm	B mm	C mm	
4535-21	2,70	314397	12	30	2	20	525
4535-24	2,85	314403	12	50	3	40	600
4535-30	2,95	314410	12	60	3	20	770

American teeth for green wood cutting.



► FINE AMERICAN TEETH BOW BLADE 4536

REF.	€	8 41 4299	g	A mm	B mm	C mm	
4536-21	2,77	032703	12	39	0,9	18	525
4536-24	2,92	032741	12	50	1	20	600
4536-30	3,03	032789	12	60	1	20	750

Fine American teeth, for clean cutting of green wood.



► UNIVERSAL TEETH BOW BLADE 4537

REF.	€	8 41 4299	g	A mm	B mm	C mm	
4537-21	2,70	314427	12	40	3	40	540
4537-24	2,85	314434	12	50	3	20	600
4537-30	3,03	314441	12	60	3	40	770

Universal teeth for dry wood cutting..



► FINE UNIVERSAL TEETH BOW BLADE 4538

REF.	€	8 41 4299	g	A mm	B mm	C mm	
4538-21	2,77	439793	12	50	2	25	520

Fine universal teeth, for clean cutting of green wood.

BOW SAWS

- Special Bellota anchoring system: safe, comfortable and stable bow blade assembly.
- Centred and straight blade for easy straight cutting.
- High-frequency induction tempered blades for improved teeth durability.
- Heat-treated teeth for maximum strength and performance.

Uses:

- For cutting branches and wood.
- For pruning tasks and cleaning woody plants, fruit trees and bushes.
- For formwork.



FINE AMERICAN TEETH BOW SAW 45391

REF.	€	8 41 4299	g	A mm	B mm	C mm
45391-21	8,76	710861	12	460	25	210
45391-24	9,44	710885	12	540	25	220
45391-30	10,09	710908	12	756	25	235

Fine American teeth, for clean cutting of green branches.



UNIVERSAL TEETH BOW SAW 45401

REF.	€	8 41 4299	g	A mm	B mm	C mm
45401-21	8,76	710922	12	460	25	210
45401-24	9,44	710946	12	540	25	220
45401-30	10,09	710960	12	756	25	235

Universal teeth for dry wood cutting.

A BOW SAW FOR EVERY SIZE

For the size 21



For the size 24



For the size 30



AXES

AXES FOR CHOPPING WOOD

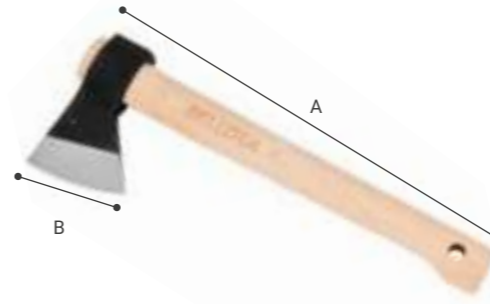

AXE 8130 C

REF.	€	8 41 4299	g	A mm	B mm	C mm	M
8130-1000C	36,81	708097	6	1.350	42	170	600
8130-300C	21,68	707977	6	500	30	119	380
8130-400C	23,86	707991	6	630	30	128	380
8130-500C	26,19	708011	6	730	32	133	400
8130-600C	27,98	708035	6	815	34	142	400
8130-700C	30,60	708059	6	1.000	34	151	450
8130-800C	32,61	708073	6	1.080	35	158	450
8130-1200C	38,97	708110	6	1.660	43	180	700
8130-1500C	43,87	708134	6	2.070	46	195	800
8130-2000C	51,61	708158	6	2.615	49	215	800

PRUNING AXE 8131

REF.	€	8 41 4299	g	A mm	B mm	C mm	M
8131-300	38,25	835762	6	630	30	165	480
8131-300 SM	28,46	835793	24	440	30	165	65

For cleaning and tree pruning.

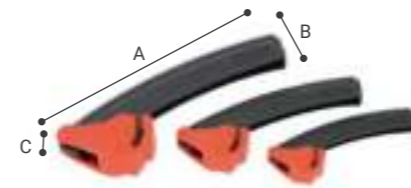

UNIVERSAL PROTECTOR FOR AXES 8130

REF.	€	8 41 4299	g	A mm	B mm	C mm	Destino
P8130-1	3,91	661965	6	12	15,2	90	3480 8130300C 8130400C 8130500C
P8130-2	4,89	661996	6	25	20	110	8130600C 8130700C 8130800C 81301000C
P8130-3	5,88	662023	6	50	50	140	81301200C 81301500C 81302000C

MEASUREMENT TABLE

300N	78-95 mm	
400N		
500N		
600N	99-113 mm	
700N		
800N		
1000N		
1200N	124-148 mm	
1500N		
2000N		
2000N		

Designed for Bellota axe and suitable for similar geometries.

AXES

- Head with non-stick coating for a clean cut without effort, comfortable notch for easy pulling out of nails.
- Injected handle on the head for a perfect union. Hollow and light fiberglass handles.

Uses:

- For wood cutting jobs. For cleaning and pruning of trees.



► GARDEN LINE AXE 3480

REF.	€	8 41 4299	g	A mm	B mm	C mm	M
3480	63,13	637526	3	780	20	130	400 P81301

WEDGES

- Manufactured with Special Bellota Steel.
- Forged in one single piece, unbreakable.
- 3+ steel treatment for a longer tool life: doesn't break, warp or wear away.
- Perfect joint between blade and handle for safety of the user.
- Special edge design to ensure good branch penetration without jamming. Clean and easy cutting.
- Special paint and varnish to avoid rust of head.
- Two types of handles:
 - Beech handle: light and comfortable touch. PEFC certified.
 - Unbreakable Carbon Fiber handle. Ergonomic design with SOFT TOUCH for comfort during work.

Uses:

- Sledgehammer-Wedge: for cutting thick and hard wood. Double use: Using the wedge as an axe for cutting wood.
- Wedges: for cutting and breaking up wood, to use with sledgehammer or sledgehammer-Wedge.

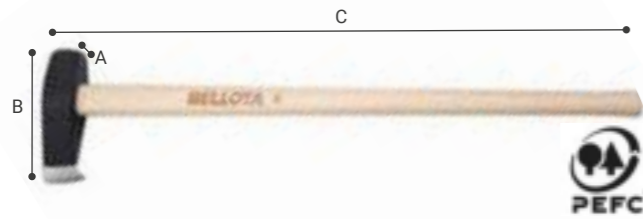

► SLEDGEHAMMER-WEDGE 5460

REF.	€	8 41 4299	g	A mm	B mm	C mm	M
5460-3	68,62	124002	6	3.580	70	210	895 M54603

To prepare wood.



► SLEDGEHAMMER-WEDGE 5460

REF.	€	8 41 4299	g	A mm	B mm	C mm	M
5460-3 CF	77,94	625257	6	3.990	70	210	900 M52006CF

To prepare wood.

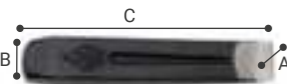

► WEDGE 5461

REF.	€	8 41 4299	g	A mm	B mm	C mm
5461-1	24,35	124101	6	1.000	35	185
5461-1,5	30,54	124200	6	1.500	40	210
5461-2	36,74	124309	6	1.970	45	225
5461-2,5	41,22	124408	6	2.500	48	255
5461-3	46,80	124507	6	2.880	52	270

MACHETES

- Manufactured with Special Bellota Steel.
- Laminated blades, conical blades for improved easy cutting.
- Optimum hardness, flexibility and resistance.
- Blade is continuous through the length of the handle.
- Three types of handles:
 - Varnished wooden handles, light and comfortable touch.
 - Dual-material handle: anatomic and anti-slip, provides comfort and safety.
 - Plastic handle high impact polypropylene, flexible.

Uses:

- For clearing brushwood, weeds and small branches.
- For multiple crops: sugar cane, coffee, etc.

B: Blade thickness (mm).

PBM: Blade Polished / Bi-material Handle

PBMA: Blade Polished / Bi-material Sharp handle

PMM: Blade Polished / Wood handle

PPN: Blade polished / Black Plastic handle

NMM: Non Polished (Raw) / Wood handle

Note: All Machetes orders have a minimum quantity requirement, except those that are marked with *.

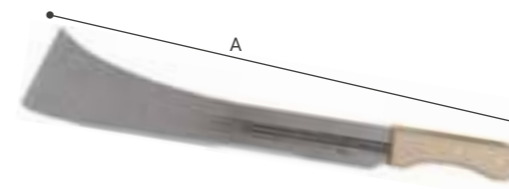

► MACHETE 202

REF.	€	8 41 4299	Pallet	g	A inches/mm	B mm
202-19,5-3 PMM	770,29	56007753	60	1.620	831 19,5"/ 495	3



► MACHETE 204

REF.	€	8 41 4299	Pallet	g	A inches/mm	B mm
204-18-3 PMM	770,29	56020158	60	1.620	758 18"/ 457	3



► MACHETE 1778

REF.	€	8 41 4299	Pallet	g	A inches/mm	B mm
1778-18-2,4 PMM	770,29	56020165	60	1.620	614 18"/ 457	2,4
1778-22-2,4 PMM	770,29	56006978	60	1.620	685 22"/ 559	2,4



► MACHETE 368

REF.	€	8 41 4299	Pallet	g	A inches/mm	B mm
368-16-3 PMM	770,29	56019930	60	1.620	565 16"/ 406	2,4



► MACHETE 448

REF.	€	8 41 4299	Pallet	g	A inches/mm	B mm
448-21-3 PMM	770,29	56020172	60	1.620	792 21"/ 533	3



► MACHETE 443

REF.	€	8 41 4299	Pallet	g	A inches/mm	B mm
443-18-3 PMM	770,29	56011446	60	1.620	700 18"/ 457	3



► MACHETE 244

REF.		Pallet	g	A inches/mm	B mm
244-18-3 PMM	7702956020141	60	1.560 677	18"/ 457	3



► MACHETE 1055

REF.		Pallet	g	A inches/mm	B mm
1055-22-3 PPN	7702956019916	60	1.620 510	22"/ 559	3



► MACHETE W550

REF.		Pallet	g	A inches/mm	B mm
W550-22-3 PMM	7702956020202	60	1.620 583	22"/ 559	3



► MACHETE 1779

REF.		Pallet	g	A inches/mm	B mm
1779-22-2,4 PMM	7702956007241	60	1.620 635	22"/ 559	2,4



► MACHETE 31W

REF.		Pallet	g	A inches/mm	B mm
31W-14-2 PMM	7702956020264	60	1.620 366	14"/ 356	2
31W-16-2 PMM	7702956020271	60	1.620 385	16"/ 406	2
31W-18-2 PMM	7702956020288	60	1.620 436	18"/ 457	2
31W-20-2 PMM	7702956020295	60	1.620 485	20"/ 508	2
31W-22-2 PMM	7702956009702	60	1.620 495	22"/ 559	2



► MACHETE 410

REF.		Pallet	g	A inches/mm	B mm
410-19,5-3 PMM	7702956020189	60	1.620 570	19,5"/ 495	3



► MACHETE 741

REF.		Pallet	g	A inches/mm	B mm
741-18-3 PMM	7702956020196	60	1.560 710	18"/ 457	3



► MACHETE 638

REF.		Pallet	g	A inches/mm	B mm
638-16-3 PMM	7702956019954	60	1.620 575	16"/ 406	3



► MACHETE 31B

REF.		Pallet	g	A inches/mm	B mm
31B-14-2 PPN	7702956020219	60	1.620 340	14"/ 356	2
31B-16-2 PPN	7702956020226	60	1.620 370	16"/ 406	2
31B-18-2 PPN	7702956020233	60	1.620 395	18"/ 457	2
* 31B-20-2 PPN	26,90 968002	12	576 450	20"/ 508	2
31B-22-2 PPN	7702956020257	60	1.620 470	22"/ 559	2



► MACHETE 127H

REF.		Pallet	g	A inches/mm	B mm
127H-16-2 PPN	7702956020301	60	1.620 365	16"/ 406	2
127H-18-2 PPN	7702956020318	60	1.620 408	18"/ 457	2
127H-20-2 PPN	7702956020325	60	1.620 433	20"/ 508	2
127H-22-2 PPN	7702956020332	60	1.620 463	22"/ 559	2
127H-24-2 PPN	7702956020349	60	1.620 495	24"/ 610	2



► MACHETE 2127H

REF.		Pallet	g	A inches/mm	B mm
2127H-16-2 PBM	7702956020356	60	1.620 373	16"/ 406	2
2127H-18-2 PBM	7702956020363	60	1.620 420	18"/ 457	2
2127H-20-2 PBM	7702956020370	60	1.620 450	20"/ 508	2
2127H-22-2 PBM	7702956020387	60	1.620 470	22"/ 559	2
2127H-24-2 PBM	7702956020394	60	1.620 510	24"/ 610	2



► MACHETE 2127F

REF.		Pallet	g	A inches/mm	B mm
2127F-16-2 PBM	7702956020455	60	1.620 373	16"/ 406	2
2127F-18-2 PBM	7702956020462	60	1.620 420	18"/ 457	2
2127F-20-2 PBM	7702956020479	60	1.620 450	20"/ 508	2
2127F-22-2 PBM	7702956020486	60	1.620 470	22"/ 559	2
2127F-24-2 PBM	7702956020493	60	1.620 510	24"/ 610	2



► MACHETE 2460

REF.		Pallet	g	A inches/mm	B mm
2460-16-2 PBM	7702956020554	60	1.620 370	16"/ 406	2
2460-18-2 PBM	7702956020561	60	1.620 410	18"/ 457	2
2460-20-2 PBM	7702956020578	60	1.620 425	20"/ 508	2
2460-22-2 PBM	7702956020585	60	1.620 460	22"/ 559	2
2460-24-2 PBM	7702956020592	60	1.620 480	24"/ 610	2



► MACHETE 2128F

REF.		Pallet	g	A inches/mm	B mm
2128F-18-2 PPN	7702956020646	60	1.620 401	18"/ 457	2
2128F-20-2 PPN	7702956020653	60	1.620 450	20"/ 508	2
2128F-22-2 PPN	7702956020660	60	1.620 477	22"/ 559	2
2128F-24-2 PPN	7702956020677	60	1.620 507	24"/ 610	2



► MACHETE 127F

REF.		Pallet	g	A inches/mm	B mm
127F-16-2 PPN	7702956020400	60	1.620 365	16"/ 406	2
127F-18-2 PPN	7702956020417	60	1.620 408	18"/ 457	2
127F-20-2 PPN	7702956020424	60	1.620 433	20"/ 508	2
127F-22-2 PPN	7702956020431	60	1.620 463	22"/ 559	2
127F-24-2 PPN	7702956020448	60	1.620 495	24"/ 610	2



► MACHETE 460

REF.		Pallet	g	A inches/mm	B mm
460-16-2 PPN	7702956020509	60	1.620 370	16"/ 406	2
460-18-2 PPN	7702956020516	60	1.620 395	18"/ 457	2
460-20-2 PPN	7702956020523	60	1.620 440	20"/ 508	2
460-22-2 PPN	7702956020530	60	1.620 470	22"/ 559	2
460-24-2 PPN	7702956020547	60	1.620 500	24"/ 610	2



► MACHETE 128F

REF.		Pallet	g	A inches/mm	B mm
128F-18-2 PPN	7702956020608	60	1.620 395	18"/ 457	2
128F-20-2 PPN	7702956020615	60	1.620 444	20"/ 508	2
128F-22-2 PPN	7702956020622	60	1.620 470	22"/ 559	2
128F-24-2 PPN	7702956020639	60	1.620 500	24"/ 610	2



► MACHETE 32L

REF.		Pallet	g	A inches/mm	B mm
32L-16-3 PMM	7702956009764	60	1.620 492	16"/ 406	3
32L-18-3 PMM	7702956009795	60	1.620 553	18"/ 457	3
32L-20-3 PMM	7702956009825	60	1.620 594	20"/ 508	3
32L-22-3 PMM	7702956009856	60	1.620 649	22"/ 559	3
32L-24-3 PMM	7702956009887	60	1.620 747	24"/ 610	3



► MACHETE 350

REF.	€	8 41 4299	Pallet	g	A inches/mm	B mm
* 350-14-2 PMM	32,90	200478	12 864 490	14"/ 356	2	
* 350-16-2 PMM	31,95	200546	12 540 518	16"/ 406	2	
350-18-2 PMM		7702956020707	60 1.620 555	18"/ 457	2	
* 350-20-2 PMM	26,90	200614	12 576 550	20"/ 508	2	
350-22-2 PMM		7702956020721	60 1.620 595	22"/ 559	2	



► MACHETE 1002

REF.	€	8 41 4299	Pallet	g	A inches/mm	B mm
1002-14-1,8 PMM		7702956020738	60 1.620 592	14"/ 356	1,8	



► MACHETE 1004

REF.	€	8 41 4299	Pallet	g	A inches/mm	B mm
1004-14-1,8 PMM		7702956020745	60 1.620 612	14"/ 356	1,8	



► MACHETE 1060

REF.	€	8 41 4299	Pallet	g	A inches/mm	B mm
1060-11-1,3 PMM		7702956020769	60 1.620 494	11"/ 279	1,3	



► MACHETE 781

REF.	€	8 41 4299	Pallet	g	A inches/mm	B mm
781-26-2 NMM		7702956015079	60 1.620 469	26"/ 660	2	



► MACHETE 5813

REF.	€	8 41 4299	Pallet	g	A inches/mm	B mm
5813-1,6 NMM		7702956020776	100 2.700 172	6"/ 152	1,6	



► MACHETE 465

REF.	€	8 41 4299	Pallet	g	A inches/mm	B mm
* 465-12 PBMA	55,76	620139	12 864 250	12"/ 304	1,8	

SCYTHES

- Manufactured with Special Bellota Steel.
- Tempered and perfectly tensioned for maximum cutting.
- Special sharpening of edge to ensure uniform blade thickness.
- With edge protection for greater safety.

Uses:

- For general mowing. Especially designed for confined or difficult spaces.



► SCYTHE 2503

REF.	€	8 41 4299	g	A mm	B mm	C mm	M	L mm
2503-20	81,84	116700	6	710	80	125	600	M2503R 510
2503-22	84,15	116809	6	780	50	600	130	M2503R 560
2503-24	89,90	116908	6	760	80	130	700	M2503R 610
2503-26	95,48	117004	6	1.020	90	150	760	M2503R 660



► SCYTHE 2506

REF.	€	8 41 4299	g	A mm	B mm	C mm	M	L mm
2506-20	87,86	117707	6	760	95	175	580	M2503R 510
2506-22	91,83	117806	6	770	90	180	620	M2503R 560



► SCYTHE 2509

REF.	€	8 41 4299	g	A mm	B mm	C mm	M	L mm
2509-22	81,62	118308	6	590	70	100	645	M2503R 578
2509-24	84,89	118407	6	650	80	110	670	M2503R 610
2509-26	88,82	118506	6	670	70	110	750	M2503R 660
2509-28	93,87	118605	6	730	70	100	800	M2503R 707

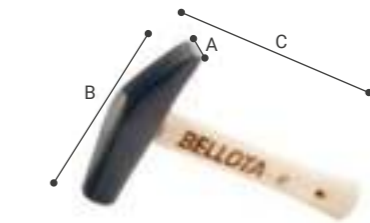

► HAMMER FOR SCYTHES 1071

REF.	€	8 41 4299	g	A mm	B mm	C mm
1071	36,93	116205	6	720	34	130 200



For scythes sharpening and shaping, together with the hammer in order to ensure a good finishing.

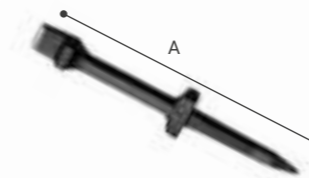

► ANVIL FOR SCYTHES 1051

REF.	€	8 41 4299	g	A mm	B mm	C mm
1051	69,10	115703	12	1.650	40	65 400

For scythes sharpening and shaping, together with the hammer in order to ensure a good finishing.

SICKLES

- Manufactured with Special Bellota Steel.
- Laminated blades, conical blades for improved easy cutting.
- Two blades models:
 - Serrated sickles: pitted on one side, ground on the other and induction tempered.
 - Edging sickles: ground on both sides and fully tempered.
- With edge guard for greater safety.
- Wooden handles, light and comfortable touch with ferrule handle and blade mounting.

Uses:
 • For mowing with one hand in confined or difficult spaces. For cutting grass and undergrowth.

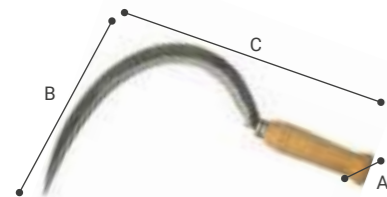

► SERRATED SICKLE 2550

REF.	€	8 41 4299	g	A mm	B mm	C mm	L mm
2550-000 N	11,54	159899	6	196	40	320	370
2550-00 N	11,75	159905	6	200	32	330	394
2550-0 N	12,38	159912	6	310	32	340	421
2550-1 N	12,79	159929	6	220	33	290	437
2550-2 N	13,12	159936	6	240	33	210	370



► SERRATED SICKLE 2551

REF.	€	8 41 4299	g	A mm	B mm	C mm	L mm
2551	12,88	158588	6	230	40	230	460



► SERRATED SICKLE 2552

REF.	€	8 41 4299	g	A mm	B mm	C mm	L mm
2552	13,24	158595	6	220	55	33	450



► EDGING SICKLE 2560

REF.	€	8 41 4299	g	A mm	B mm	C mm	L mm
2560-0	22,73	158601	6	260	40	380	400
2560-1	22,91	158618	6	300	40	390	445
2560-2	24,03	158625	6	330	32	240	430
2560-3	25,97	159943	6	390	32	285	460



► EDGING SICKLE 2561

REF.	€	8 41 4299	g	A mm	B mm	C mm	L mm
2561	28,30	158632	6	500	40	500	515



► EDGING SICKLE 2562

REF.	€	8 41 4299	g	A mm	B mm	C mm	L mm
2562	21,29	158649	6	250	40	360	440



► EDGING SICKLE 2563

REF.	€	8 41 4299	g	A mm	B mm	C mm	L mm
2563	25,89	158656	6	250	34	210	380



BILL HOOKS

- Manufactured with Special Bellota Steel.
- 3+ steel treatment for a longer tool life: doesn't break, warp or wear away.
- Precision sharpening for clean and uniform cut.

Uses:
 • For cutting weeds and brambles.
 • For deep pruning and cleaning of branches.
 • For cleaning palm trees.

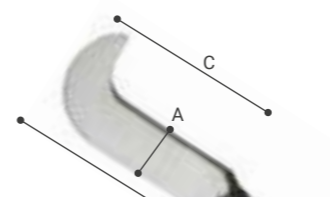

► BILL HOOK 1111

REF.	€	8 41 4299	g	A mm	B mm	C mm	L mm
1111-A	71,04	116403	12	870	42	400	132

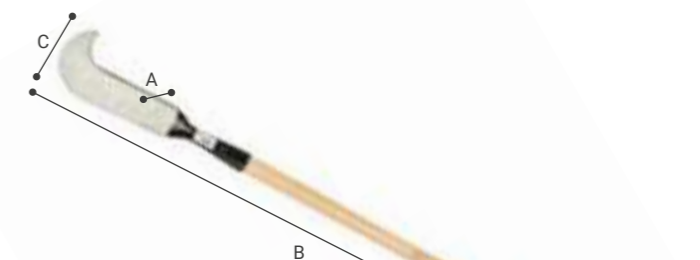

► BILL HOOK WITH HANDLE 1111

REF.	€	8 41 4299	g	A mm	B mm	C mm	L mm
1111-A CM	83,31	652024	2	870	42	400	132



► BILL HOOK 1116

REF.	€	8 41 4299	g	A mm	B mm	C mm	L mm
1116	94,38	116502	12	780	115	365	210



► BILL HOOK WITH HANDLE 1116

REF.	€	8 41 4299	g	A mm	B mm	C mm	L mm
1116 CM	106,67	652048	2	780	115	365	210



► BILL HOOK 1118

REF.	€	8 41 4299	g	A mm	B mm	C mm	L mm
1118-A	52,80	116601	12	770	38	140	300



► BILL HOOK WITH HANDLE 1118

REF.	€	8 41 4299	g	A mm	B mm	C mm	L mm
1118-A CM	67,37	652062	2	770	38	140	300



AGRICULTURAL FILES

- Manufactured with Special Bellota Steel.
- Forged in one single piece, unbreakable.
- 3+ steel treatment for a longer tool life: doesn't break, warp or wear away.
- Each fle has the perfect hardness, to get the maximum durability, depending on the work to be done.
- Uniform teeth for a uniform result.
- Option to put a dual material ergonomic handle with SOFT TOUCH for comfort during work.

SHARPENING FILES

- For sharpening machetes, hoes, saws and all types of agricultural tools.

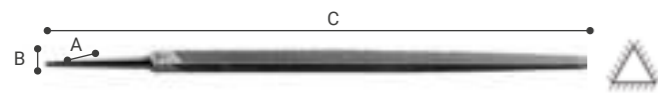

▶ SHARPENING TRIANGULAR EXTRA THIN FILE FOR SAW 4040

REF.	€	8 41 4299	g	A mm	B mm	C mm	L1 mm	L2 mm	M	
4040-5	8,76	431605	12	20	6	6	165	5 / 125	4,8	40902 4093B5 40891
4040-6	9,20	431803	12	30	8	7	195	6 / 150	6,1	40892 40903 4093B4

Triangular file.



▶ SHARPENING TRIANGULAR THIN FILE FOR SAW 4041

REF.	€	8 41 4299	g	A mm	B mm	C mm	L1 mm	L2 mm	M	
4041-4	6,99	432305	12	20	5,5	5,5	135	4 / 100	6,9	4093B5 40891
4041-5	7,12	432701	12	20	7	7	165	5 / 125	7	40892 40902 4093B5
4041-6	7,72	432909	12	50	9	9	195	6 / 150	9	40892 40903 4093B3
4041-7	8,50	433104	12	70	10	10	225	7 / 175	10	40893 40904 4093B3
4041-8	10,54	433302	12	90	11	11	255	8 / 200	11	40893 40904 4093B2

Triangular file.



▶ SHARPENING TRIANGULAR NORMAL FILE FOR SAW 4042

REF.	€	8 41 4299	g	A mm	B mm	C mm	L1 mm	L2 mm	M	
4042-3 V	6,40	433609	12	10	6	6	112	3 / 75	6	4093B5 40891
4042-4 V	6,47	434002	12	30	9	9	138	4 / 100	9	40892 4093B4
4042-5 V	7,27	434606	12	50	11	11	170	5 / 125	11	40893 40902 4093B3
4042-6 V	8,53	435009	12	70	10	10	196	6 / 150	10	40893 40903 4093B3
4042-7 V	9,93	435405	12	110	13	12	235	7 / 175	12	40893 40904 4093B3
4042-8 V	11,03	435801	12	140	14	14	245	8 / 200	14	40894 40904 4093B2
4042-9 V	12,95	436204	12	240	17	17	301	9 / 225	17	40894 40905 4093B2
4042-10 V	14,53	436501	12	270	17	17	321	10 / 250	17	40897 40905 4093B1

Triangular file.



▶ BIMATERIAL HANDLE SHARPENING TRIANGULAR NORMAL FILE FOR SAW 4042

REF.	€	8 41 4299	g	A mm	B mm	C mm	L1 mm	L2 mm	M	
4042-3 V MB	8,54	136944	6	80	30	30	225	3 / 75	6	4093B5
4042-4 V MB	8,31	137262	6	90	30	30	225	4 / 100	9	40892 4093B4
4042-5 V MB	9,73	137019	6	110	30	30	249	5 / 125	11	40893 40902 4093B3
4042-6 V MB	10,45	130973	6	130	30	30	276	6 / 150	10	40893 40903 4093B3
4042-7 V MB	12,18	136692	6	160	32	32	300	7 / 175	12	40893 40904 4093B3
4042-8 V MB	13,47	136760	6	200	30	30	322	8 / 200	14	40894 40904 4093B2

Triangular file.



▶ BIMATERIAL HANDLE SHARPENING FLAT PARALLEL FILE FOR SAW (ONE ROUNDED EDGE) 4045

REF.	€	8 41 4299	g	A mm	B mm	C mm	L1 mm	L2 mm	M	
4045-6 1CR MB	15,91	137330	6	120	30	30	280	150	-	4093B5
4045-8 1CR MB	18,57	137392	6	160	32	32	330	200	-	4093B4

Mill saw file.



▶ SHARPENING ROUNDED FILE FOR CHAINSAW 4050

REF.	€	8 41 4299	g	A mm	B mm	C mm	L1 mm	L2 mm	M	
4050-8x4,0	1,56	442601	12	20	4	4	245	8 / 200	4	4093B4
4050-8x4,5	1,56	469363	12	20	4	4	246	8 / 200	4	4093B4
4050-8x4,8	1,56	442502	12	30	5	5	246	8 / 200	5	4093B4
4050-8x5,5	1,56	442700	12	40	5	5	245	8 / 200	5	4093B4
4050-8x4,0 BS	3,44	612059	6	20	4	4	248	8 / 200	4	4093B4
4050-8x4,5 BS	3,44	612073	6	20	4	4	245	8 / 200	4	4093B4
4050-8x4,8 BS	3,44	612097	6	30	4	4	246	8 / 200	4	4093B4
4050-8x5,5 BS	3,44	612110	6	40	5	5	246	8 / 200	5	4093B4
4050-8x3,2	1,56	673715	12	10	3	3	247	8 / 200	3	4093B4
4050-8x3,6	1,56	673975	12	10	3	3	245	8 / 200	3	4093B4

Round file.



▶ SHARPENING TRIANGULAR FILE FOR MACHETE 4081

REF.	€	8 41 4299	g	A mm	B mm	C mm	L1 mm	L2 mm	M	
4081-5	6,72	466607	12	60	11	11	171	5 / 125	11	40893 40902 4093B3
4081-6	7,58	466706	12	70	11	11	195	6 / 150	11	40894 40903 4093B3
4081-7	9,13	466805	12	110	14	14	235	7 / 175	14	40894 40904 4093B3
4081-8	11,09	466904	12	140	14	15	260	8 / 200	15	40894 40904 4093B2
4081-10	14,58	469233	12	250	18	18	327	10 / 250	18	40897 40905 4093B1

Triangular file.

FARRIER TOOLS

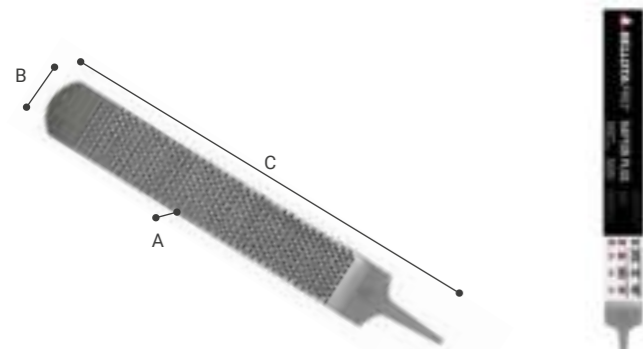

▶ HORSESHOEING RASP RAPTOR PLUS 4140

REF.	€	8 41 4299	g	A mm	B mm	C mm	L mm
41401418RAF	51,45	7500372015204	6	828	5	57	430



▶ HORSESHOEING RASP PRIME FINISH PLUS 4139

REF.	€	8 41 4299	g	A mm	B mm	C mm	L mm
41391417RAF	38,20	7500372015174	6	620	5	45	430

* Served upon request.



▶ HORSESHOEING RASP PRIME LEVEL 4137

REF.	€	8 41 4299	g	A mm	B mm	C mm	L mm
41371415RAF	45,38	7500372015112	6	653	4,5	50	430



▶ HORSESHOEING RASP LEVEL LONG 4138

REF.	€	8 41 4299	g	A mm	B mm	C mm	L mm
41381716RAF	45,38	7500372015143	6	780	4,5	50	457



▶ TOP LEVEL HORSESHOEING RASP

REF.	€	8 41 4299	g	A mm	B mm	C mm	L mm
413614RAF	45,38	7500372014511	6	653	4,5	50	430



▶ CLASSIC HORSESHOEING RASP 4132

REF.	€	8 41 4299	g	A mm	B mm	C mm	L mm
4132148RAF	42,69	7500372009340	6	622	5	45	430

Smooth finishing..



▶ TOP SHARP HORSESHOEING RASP 4132

REF.	€	8 41 4299	g	A mm	B mm	C mm	L mm
4132147RAF	42,69	7500372009319	6	622	5	45	430

Fast finishing.



▶ TWO-HANDED HORSESHOEING RASP 4133

REF.	€	8 41 4299	g	A mm	B mm	C mm	L mm
41331411RAF	46,98	7500372009364	6	593	5	45	355
41331611RAF	51,44	7500372010902	6	678	5	45	406

Flat file. Four sides.



▶ HORSESHOEING RASP RAZOR PLUS 4131

REF.	€	8 41 4299	g	A mm	B mm	C mm	L mm
4131142RAFP	46,62	7500372009999	6	622	5	45	430



▶ CLASSIC HORSESHOEING RASP 4132

REF.	€	8 41 4299	g	A mm	B mm	C mm	L mm
413208RAFMB	37,25	7500372010414	4	415	5	45	330



▶ BIG RAPTOR PLUS RASP

REF.	€	8 41 4299	g	A mm	B mm	C mm	L mm
RFA411PA	51,80	7500372706161	6	1.013	5	57	507

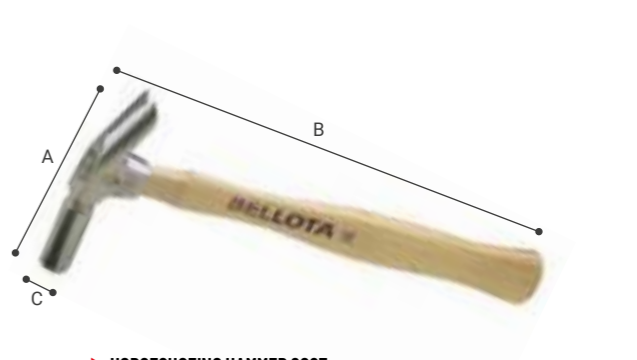

▶ HORSESHOEING HAMMER 8027

REF.	€	8 41 4299	g	A mm	B mm	C mm	L mm
8027	41,84	144604	6	240	24	110	310
8027SM	26,47	144703	12	170			



▶ HANDLE FOR RASPS 4090-7

REF.	€	8 41 4299	g	A mm	B mm	C mm
4090-7	6,12	184341	24	110	50	100



▶ HANDLE FOR RASPS 4090-7 NG

REF.	€	8 41 4299	g	A mm	B mm	C mm
4090-7NG	6,12	184341	24	110	50	100



▶ BIMATERIAL HANDLE FOR RASPS 7HDLA5BM

REF.	€	8 41 4299	g	A mm	B mm
7HDLA5BM	7,25	7750037212747	12	110	119

ACCESSORIES FOR AGRICULTURE

GLOVES

- Innovative materials and comfortable designs suitable for each task.
- Different textures, maximum sensitivity and protection.

Uses:

- For main gardening tasks: transplanting, pruning, maintenance watering, fumigation.

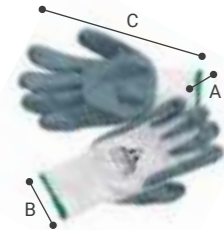

► CONFORT GLOVE 75101

REF.	€	8 41 4299	g	A mm	B mm	C mm	Mbox	Talla
75101-7/S	6,16	534344	10	50	20	120	260	120 7/S
75101-8/M	6,16	533989	10	50	15	120	235	120 8/M
75101-9/L	6,16	534009	10	50	20	90	230	120 9/L

For transplanting and garden maintenance tasks.



► GRIP GLOVE 75102

REF.	€	8 41 4299	g	A mm	B mm	C mm	Mbox	Talla
75102-8/M	6,42	534023	10	50	20	110	220	120 8/M
75102-9/L	6,25	534047	10	70	20	110	230	120 9/L
75102-10/XL	6,25	534061	10	67	10	110	275	120 10/XL

For transplanting and garden maintenance tasks.



► HYDRO GLOVE 75103

REF.	€	8 41 4299	g	A mm	B mm	C mm	Mbox	Talla
75103-8/M	4,98	534085	10	78	20	140	380	100 8/M

For transplanting and gardening tasks in wet conditions.



► UNIVERSAL GLOVE 75104

REF.	€	8 41 4299	g	A mm	B mm	C mm	Mbox	Talla
75104-7/S	6,42	534122	10	45	10	100	220	120 7/S
75104-8/M	6,42	534146	10	50	10	100	225	120 8/M
75104-9/L	6,25	534160	10	60	20	110	230	120 9/L
75104-10/XL	6,25	534184	10	60	10	110	250	120 10/XL

For gardening maintenance purpose.



► 4X4 GLOVE 75105

REF.	€	8 41 4299	g	A mm	B mm	C mm	Mbox	Talla
75105-8/M	7,46	534207	10	125	20	120	270	120 8/M
75105-9/L	7,46	534221	10	110	20	130	250	120 9/L
75105-10/XL	7,26	534245	10	138	20	120	240	120 10/XL

For pruning and gardening task purpose.



► PROTECT GLOVE 75106

REF.	€	8 41 4299	g	A mm	B mm	C mm	Mbox	Talla
75106-9/L	10,36	534283	10	130	20	130	470	60 9/L
75106-10/XL	10,36	534306	10	140	20	140	500	60 10/XL
75106-8/M	10,36	534269	10	120	20	130	380	60 8/M

Pruning trees, bushes and thorny plants.

KNEEPADS



► GARDEN KNEEPADS KPGA1S

REF.	€	8 41 4299	g	A mm	B mm	C mm	Talla
KPGA1S	11,26	705089	6	140	250	200	70 Única

LUBRICANT

- Optimised blends for improved machinery performance.

Uses:

- Grease for parts and engines.



► LUBRICANTS FOR PREPARING CHAINSAWS 3660

REF.	€	8 41 4299	g	A mm	B mm	C mm	ml
3660	12,95	299397	20	970	75	110	220 1000

To lubricate chains with cutting blades on mechanical saws and chainsaws.



► LUBRICANT FOR ENGINES 3661

REF.	€	8 41 4299	g	A mm	B mm	C mm	ml
3661-2T	17,26	299519	20	980	70	115	220 1000
3661-4T	17,63	299595	20	960	70	115	220 1000

For all kinds of four-stroke engines.



► MULTIUSE LUBRICANT 6660

REF.	€	8 41 4299	g	A mm	B mm	C mm	ml
6660	9,66	299458	24	210	53	53	175 270

Loosens, lubricates and protects.



► MULTIUSE LUBRICANT 6661

REF.	€	8 41 4299	g	A mm	B mm	C mm	ml
6661	10,93	299762	24	220	53	53	170 270

Loosen and release all kinds of screws, nuts, bolts, pins, threaded joints, etc. Loosen seized up mechanisms. Dismantle rusted and corroded pieces and accessories.



► MULTIUSE LUBRICANT 6662

REF.	€	8 41 4299	g	A mm	B mm	C mm	ml
6662	15,38	299854	12	370	66	66	210 400

To solve problems when lubricating mechanisms that must work at temperatures from -55 to 150C. Without losing its lubricating properties. A film lubrication is preserved to stop metal coming directly into contact with metal between the surfaces that have to be lubricated, despite the significant variation in the working conditions.

LITHIUM GREASE



► MULTIPURPOSE LITHIUM GREASE 6663

REF.	€	8 41 4299	g	A mm	B mm	C mm	ml
6663	9,00	299915	24	150	47	80	165 150

For bearings used at very high temperatures and loads.



► LITHIUM GREASE 3662

REF.	€	8 41 4299	g	A mm	B mm	C mm	ml
3662-1	19,41	605877	12	1.180	115	115	160 1000
3662-5	64,88	299717	4	5.530	190	190	270 5000

For ball bearings, roller bearings, axle bearings and all kinds of parts that are used at temperatures of between -20 to 120 °C

SPRAYERS

BACKSACK SPRAYER

- Perforation free tank with a wider thread to avoid possible leaks.
- High performance: the bottle design reduces the amount of pumping.
- High-quality nozzle for an even spray. Adjustable jet cone.
- Maximum comfort, with adjustable cushioned straps.
- Operating pressure of 1-3 bar.
- Arm length 60 cm. Hose length 120 cm.

Uses:

- For farming and gardening fertilisation and fumigation.



▶ 16L AND 12 L SPRAYER 3710

REF.	€	8 41 4299	g	A mm	B mm	C mm	
3710-16	59,40	604993	1	3.400	150	420	610
3710-12	56,67	443578	1	3.200	150	400	550

Adjustable nozzle included.

* Pressure pump, specially designed for use: for fertilising and fumigation in agriculture and gardening.

** In construction, DO NOT USE WITH AGGRESSIVE PRODUCTS, such as oils, lubricants, release agents, solvents, detergents and descaling agents.

▶ PROFESSIONAL SPRAYER 5/10 LITERS 3710

REF.	€	8 41 4299	g	A mm	B mm	C mm	
3710-10	52,56	606751	1	1.750	200	200	570
3710-05	33,33	688887	1	950	200	200	570

* Pressure pump, specially designed for use: for fertilising and fumigation in agriculture and gardening.

** In construction, DO NOT USE WITH AGGRESSIVE PRODUCTS, such as oils, lubricants, release agents, solvents, detergents and descaling agents.

PARTS FOR PROFESSIONAL RANGE SPRAYERS



REF.	€	8 41 4299	Destino
R3710-1	10,00	606652	1 Arm and jet 3710-10, 3710-12, 3710-16, 3710-05
R3710-2	6,83	606669	1 Handle 3710-10, 3710-12, 3710-16, 3710-05
R3710-3	12,35	606676	1 Hose 3710-10, 3710-12, 3710-16, 3710-10
R3710-4	5,04	606683	1 12 and 16 litres pump 3710-12, 3710-16
R3710-5	3,96	606690	1 Miscellaneous 12 and 16 litres Rod, rings 3710-12, 3710-16
R3710-6	11,35	606706	1 Air chamber 16 litres 3710-16
R3710-7	10,86	606713	1 Air chamber 12 litres 3710-12
R3710-8	7,79	606720	1 10 litres pump 3710-10
R3710-9	6,43	606737	1 10 litres pump bar 3710-05, 3710-10
R3710-10	4,37	606744	1 Miscellaneous 10 litres Rod, diaphragm, ring, spring 3710-05, 3710-10
R3710-11	10,23	706277	1 5 litre hose 3710-05, 3710-10

PRE-SET PRESSURE HAND SPRAYER

- Strap handles for continuous effortless spraying.
- Adjustable nozzle for fine spraying up to a long distance jet.
- Easy maintenance and cleaning.

Uses:

- For plants watering, protecting roses, flowers and Vegetables.
- For eliminating weeds and moss on garden furniture, swings, etc.



▶ 1/1,5/2 L GARDEN SPRAYER 3700-015

REF.	€	8 41 4299	g	A mm	B mm	C mm	
3700-015	17,83	460117	1	350	120	180	305
3700-010	10,83	691108	12	340	120	180	295
3700-020	19,61	691122	12	360	120	180	310

BUCKETS

- Made of top quality 100% recycled Polyethylene. Strong, durable, easy-to-clean tubs with high thermal and chemical resistance.
- Impact resistant: Very flexible and lightweight, which makes it easier to carry around materials and rubble in them. Furthermore, the inside and the handles have been reinforced so that they do not break or crack.
- Food grade certificate to guarantee fruit and vegetable safety during transportation.

Uses:

- To carry around rubble, waste, water, sand and cement in the agricultural and construction sectors.
- Food grade certificate fruit and vegetables.

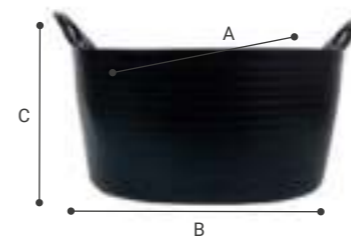

▶ 30L BLACK PLASTIC BUCKET

REF.	€	8 41 4299	g	A mm	B mm	C mm	L	
BKT30BP	5,12	676570	12	630	475	420	280	30



▶ 42L RED PLASTIC BUCKET

REF.	€	8 41 4299	g	A mm	B mm	C mm	L	
BKT42RP	6,51	676655	12	980	520	450	380	42



▶ WHITE PLASTIC BUCKET FOR FOOD USE

REF.	€	8 41 4299	g	A mm	B mm	C mm	L	
BKT42WP	10,54	676891	12	890	520	450	370	42
BKT65WP	15,24	677096	6	1.410	560	615	400	65



▶ BLUE PLASTIC BUCKET FOR FOOD USE

REF.	€	8 41 4299	g	A mm	B mm	C mm	L	
BKT42BLP	10,54	676969	12	890	520	450	380	42
BKT65BLP	15,24	677010	6	1.420	560	615	400	65

PRESSURE CLEANERS

1

► **Range variety:**

The Bellota range of pressure washers offers different flow rates and pressures, to suit the required use.

2

► **Versatility:**

Different nozzles are available to adjust the water output to the surface to be cleaned: turbo nozzle to concentrate the pressure, an adjustable nozzle and an adjustable foam sprayer.

3

► **Maximum comfort:**

Its external water inlet filter makes it easy to clean and maintain. In addition, they are able to draw water from any tank, with no need to rely on a main water supply.



PRESSURE CLEANERS COMPARISON



	HL1400E	HL1700E	HL2400PROE
Motor type	Universal brush motor	Universal brush motor	Copper-wound induction motor
Power	1,4 kW	1,7 kW	2,4 kW
Max. Pressure	120 bar	140 bar	150 bar
Max. Flow rate	330 l/h	380 l/h	500 l/h
High pressure hose	3 m (PVC)	5 m (PVC)	8 m (PVC)
Power cable	5 m	5 m	5 m
Special features	<ul style="list-style-type: none"> No Force system gun. Transport wheels. Water Suction capacity. Adjustable foam sprayer with soap reservoir. 	<ul style="list-style-type: none"> No Force system gun. Transport wheels. Water Suction capacity. Adjustable foam sprayer with soap reservoir. Hose reel. 	<ul style="list-style-type: none"> No Force system gun. Transport wheels. Water Suction capacity. Adjustable foam sprayer with soap reservoir. Hose reel.
Weight (net/gross)	5 / 6 kg	8 / 9,5 kg	19 / 21 kg
Overall dimensions product	397x238x651 mm	333x394x855 mm	303x384x916 mm
Pump type	Axial pump	Axial pump	Axial pump
Pump material	PA	Aluminium	Aluminium
Piston type	Steel	Steel	Steel

WHAT DO YOU WANT TO CLEAN UP?



	HL1400E	HL1700E	HL2400PROE
Garden tools	▲	▲	▲
Garden furniture	▲	▲	▲
Fences	▲	▲	▲
Paths	▲	▲	▲
Garden paths		▲	▲
Outdoor staircases		▲	▲
Stone walls		▲	▲
Outdoor flooring		▲	▲
Swimming pools	▲	▲	▲
Roofs		▲	▲
Façades		▲	▲
Bicycles	▲	▲	▲
Motorbikes and mopeds	▲	▲	▲
Medium-sized vehicles		▲	▲
Family vehicles		▲	▲
Vans		▲	▲
Mobile homes			▲

VACUUM MACHINE

1

► **It vacuums everything:**

Wet and dry vacuuming of solids and liquids to help you with the most complete cleaning.

2

► **Versatile:**

Synchronous socket that allows you to connect different power tools up to 1.000W to the vacuum cleaner.

3

► **Increased efficiency:**

Special blower function that helps to pile up dust and debris for faster and easier cleaning of large areas. Increased efficiency.

USES

Suction of both solid and liquid waste from workshops or different work areas.



FEATURES



ASL2500E

Motor type	Universal brush motor
Power	2 kW
Tank size	25 l
Max. Pressure	16 kPa
Max. Flow rate	28 ± 2 l/s
High pressure hose	2 m (EVA)
Power cable	5 m
Special features	<ul style="list-style-type: none"> • With special blowing function • Synchronous socket • Wet and dry suction of solids and liquids
Weight (net/gross)	4,7 / 5,2 Kg
Overall dimensions product	362x342x615 mm

ACCESSORIES IN THE CLEANING RANGE



HL1400E / HL1700E



NO FORCE GUN



LANCES



HIGH PRESSURE HOSE 3M / 5M



DETERGENT CANISTER



REMOVABLE WATER FILTER



QUICK HOSE CONNECTOR



ADJUSTABLE NOZZLE



TURBO NOZZLE



HL2400PROE



REINFORCED METAL GUN



LANCE WITH TURBO NOZZLE



LANCE WITH ADJUSTABLE NOZZLE (0°-60°)



HIGH PRESSURE HOSE 8M



REMOVABLE WATER FILTER



QUICK HOSE CONNECTOR



FOAM SPRAY NOZZLE



ASL2500E



TELESCOPIC STEEL TUBE



FLEXIBLE HOSE



NON-WOVEN FABRIC BAG



SPONGE FILTER



SWIVEL CASTORS



WATER SUCTION BRUSH



COMBINATION BRUSH



NARROW SUCTION NOZZLE

CLEANING

PRESSURE WASHERS



► HIGH PRESSURE WASHER 120 BAR HL1400E

REF.	€	8 41 4299	g	A mm	B mm	C mm	Kw	bar	l/h
HL1400E	110,60	032680	1	5.000	295	270	400	1,4	120 330



► HIGH PRESSURE WASHER 140 BAR HL1700E

REF.	€	8 41 4299	g	A mm	B mm	C mm	Kw	bar	l/h
HL1700E	172,30	032819	1	9.000	307	307	651	1,7	140 380



► HIGH PRESSURE WASHER 150 BAR HL2400PROE

REF.	€	8 41 4299	g	A mm	B mm	C mm	Kw	bar	l/h
HL2400PROE	312,30	032833	1	19.000	360	400	770	2,4	150 500

VACUUM CLEANERS



► SYNCHRONOUS VACUUM FOR LIQUIDS AND SOLIDS ASL2500SE

REF.	€	8 41 4299	g	A mm	B mm	C mm	Kw	L	kPa
ASL2500SE	88,06	032666	1	6.700	345	345	590	2	25 16

ACCESSORIES FOR HIGH PRESSURE WASHER



► ACCESSORIES FOR HIGH PRESSURE CLEANERS HL1400E / HL1700E / HL2400PROE

REF.	€	8 41 4299	g	Accessories	HL1400E / HL1700E / HL2400PROE
AC59HL2400PRO	0,40	37968	1	Cleaning needle	HL2400PROE
AC61HL1400	9,32	34639	1	Rotating power nozzle	HL1400E
AC62HL1400	7,98	34738	1	Adjustable nozzle (0°-60°)	HL1400E
AC66HL1400	19,33	35292	1	3m high-pressure hose	HL1400E / HL2400PROE / HL2400PROE
AC68HL1400	0,40	24807	1	Cleaning needle	HL1400E / HL1700E
AC80HL	21,31	76608	1	No Force gun	HL1400E / HL1700E
AC81HL	8,67	76646	1	First lance	HL1400E / HL1700E
AC82HL	8,67	76660	1	Second lance	HL1400E / HL1700E
AC83HL	13,40	76707	1	Detergent bottle	HL1400E / HL1700E
AC84HL	6,84	76738	1	Water inlet filter	HL1400E / HL1700E / HL2400PROE
AC84HL1700	7,98	37111	1	Adjustable nozzle (0°-60°)	HL1700E
AC85HL	2,48	76752	1	Quick hose connector	HL1400E / HL1700E / HL2400PROE
AC85HL1700	9,32	37135	1	Rotating power nozzle	HL1700E
AC85HL2400PRO	26,26	38279	1	Metallic gun	HL2400PROE
AC86HL1700	25,74	37159	1	5m high-pressure hose	HL1700E
AC86HL2400PRO	12,47	38309	1	Rotating power PRO lance	HL2400PROE
AC87HL2400PRO	10,96	38323	1	Adjustable power PRO lance	HL2400PROE
AC89HL2400PRO	38,42	38361	1	8m high-pressure hose	HL2400PROE
AC91HL2400PRO	8,24	38422	1	Detergent nozzle	HL2400PROE
MSF3HL	25,82	49091	1	Suction hose	HL1400E / HL1700E / HL2400PROE

ACCESSORIES FOR VACUUM CLEANERS



► ACCESSORIES FOR VACUUM CLEANER ASL2500SE

REF.	€	8 41 4299	g	Accessories	ASL2500SE
AC16ASL2500S	6,14	38750	1	Foam motor filter	ASL2500SE
AC20ASL2500S	7,68	38774	1	Fabric filter for water suction	ASL2500SE
AC27ASL2500S	14,29	38866	1	Wheel	ASL2500SE
AC38ASL2500S	16,82	38910	1	Flexible hose	ASL2500SE
AC43ASL2500S	21,02	38941	1	Telescopic metal tube	ASL2500SE
AC44ASL2500S	10,23	38965	1	Liquid and solids suction brush	ASL2500SE
AC45ASL2500S	2,52	38989	1	Combi brush	ASL2500SE
AC46ASL2500S	2,52	39009	1	Groove suction nozzle	ASL2500SE



Tools to break down
walls and build
your dreams

**FOR
CONSTRUCTION**

CONSTRUCTION SHOVELS

SHOVELS

- Made with special Bellota steel.
- 3+ steel treatment for a longer tool life: doesn't break, warp or wear away.
- Very strong, riveted holder ensuring the perfect joint between blade and handle.
- Varnished Feech handle, light, pleasant touch wooden handles. PEFC certificated. Available in T-shaped M, D (A), and long sizes (L).
- Epoxy coating to prevent rust on tool.

Uses:

- For digging and collecting rubble, cement, soil, etc.

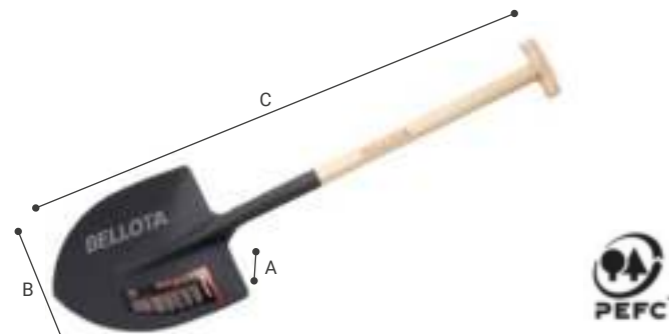

▶ T HANDLE POINTED SHOVEL 5501

REF.	€	8 41 4299	g	A mm	B mm	C mm	M
5501-2 M	23,60	500103	6	1.800	140	265	1.015 M5501M M5501A M5501L M5501MSB
5501-3 M	24,36	500400	6	1.900	150	285	1.020 M5501M M5501A M5501L M5501MSB
5501-4 M	27,93	500608	6	2.180	155	295	1.025 M5501M M5501A M5501L M5501MSB



▶ D HANDLE POINTED SHOVEL 5501

REF.	€	8 41 4299	g	A mm	B mm	C mm	M
5501-2 A	26,83	500202	6	1.800	140	265	1.015 M5501M M5501A M5501L M5501MSB
5501-3 A	27,59	500509	6	1.960	150	285	1.025 M5501M M5501A M5501L M5501MSB
5501-4 A	33,00	500707	6	2.190	155	295	1.030 M5501M M5501A M5501L M5501MSB



▶ LONG HANDLE POINTED SHOVEL 5501

REF.	€	8 41 4299	g	A mm	B mm	C mm	M
5501-2 L	31,61	500301	6	2.290	140	265	1.480 M5501M M5501A M5501L M5501MSB



▶ T HANDLE SQUARE SHOVEL 5502

REF.	€	8 41 4299	g	A mm	B mm	C mm	M
5502-2 M	24,61	501100	6	1.900	150	255	1.005 M5501M M5501A M5501L M5501MSB
5502-3 M	25,01	501308	6	2.000	160	265	1.020 M5501M M5501A M5501L M5501MSB
5502-4 M	27,93	501506	6	2.240	170	275	1.030 M5501M M5501A M5501L M5501MSB
5502-6 M	30,19	501704	6	2.660	190	305	1.050 M5501M M5501A M5501L M5501MSB



▶ D HANDLE SQUARE SHOVEL 5502

REF.	€	8 41 4299	g	A mm	B mm	C mm	M
5502-2 A	27,90	501209	6	2.190	150	255	1.010 M5501M M5501A M5501L M5501MSB
5502-3 A	28,71	501407	6	2.120	160	265	1.030 M5501M M5501A M5501L M5501MSB
5502-4 A	33,00	501605	6	2.420	170	275	1.035 M5501M M5501A M5501L M5501MSB
5502-6 A	35,36	501803	6	2.750	190	305	1.062 M5501M M5501A M5501L M5501MSB



▶ LONG HANDLE SQUARE SHOVEL 5502

REF.	€	8 41 4299	g	A mm	B mm	C mm	M
5502-2 L	31,61	501254	6	2.280	150	255	1.470 M5501M M5501A M5501L M5501MSB



▶ POINTED SHOVEL WITH LONG HANDLE / 5505L

REF.	€	8 41 4299	g	A mm	B mm	C mm	
5505L	27,75	710328	6	2.290	140	265	1.480

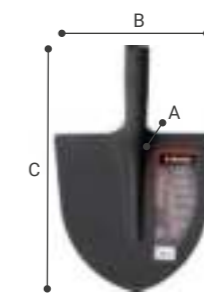

▶ POINTED SHOVEL 5550

REF.	€	8 41 4299	g	A mm	B mm	C mm	M
5550-27 SM	14,60	606829	6	940	125	270	400 M55562CSB M55562RSB
5550-29 SM	16,51	537536	130	1.050	140	295	415 M55562CSB M55562RSB
5550-31 SM	16,72	526547	120	1.300	160	310	456 M55562CSB M55562RSB



▶ LONG HANDLE POINTED SHOVEL 5550

REF.	€	8 41 4299	g	A mm	B mm	C mm	M
5550-27 MRSB	30,13	671384	2	2.100	125	270	1.420 M55562RSB
5550-27 MLSB	30,74	675290	2	1.950	125	270	1.550 M55562RSB



▶ POINTED SHOVEL 5551

REF.	€	8 41 4299	g	A mm	B mm	C mm	M
5551 SPUL	12,31	501810	20	890	95	294	373 M55562CSB M55562RSB



▶ POINTED SHOVEL 5552

REF.	€	8 41 4299	g	A mm	B mm	C mm	M
5552-26 SM	13,52	501544	25	620	60	265	340 M55562CSB M55562RSB



▶ ROUNDED SHOVEL 5556

REF.	€	8 41 4299	g	A mm	B mm	C mm	M
5556-2 SM	13,30	779790	25	890	50	264	360 M55562CSB M55562RSB



▶ LONG HANDLE ROUNDED SHOVEL 5556

REF.	€	8 41 4299	g	A mm	B mm	C mm	M
5556-2 MRSB	29,47	675276	2	2.000	60	265	1.480 M55562RSB



▶ POINTED SHOVEL 5557

REF.	€	8 41 4299	g	A mm	B mm	C mm	M
5557-23 SM	12,84	598926	25	950	43	218	375 M55562CSB M55562RSB

SCRAPER

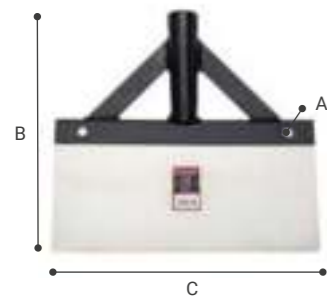

▶ REINFORCED SCRAPER 5710

REF.	€	8 41 4299	g	A mm	B mm	C mm	M
5710	20,96	638950	6	1.040	35	304	291 M5701L M5701L120

FORMWORK TOOLS

- Made with special Bellota steel.
- 3+ steel treatment for a longer tool life: doesn't break, warp or wear away.
- Heat treated heads and claws for greater resistance.
- Claw special design for minimum effort.
- Water-based paint to prevent oxidation of tools.

Uses:

- Wrecking bar: For levering and removing the form supports.
- Bending wrench: For bending ironworking during the shuttering process.

WRECKING BAR

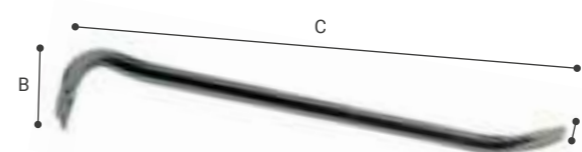

▶ WRECKING BAR 5982

REF.	€	8 41 4299	g	A mm	B mm	C mm	
5982-18x500	19,68	157000	6	1.120	30	95	500
5982-20x600	22,53	156997	6	1.710	40	105	605
5982-20x700	25,24	156980	6	2.080	48	120	706
5982-22x800	30,10	156973	6	2.790	50	130	800
5982-22x1000	37,20	156966	6	3.330	50	130	1.000
5982-22x1200	40,44	433098	4	4.100	50	135	1.200



▶ SMALL NAIL PULLER 5981

REF.	€	8 41 4299	g	A mm	B mm	C mm	
59818	15,18	705430	6	200	12	65	200
598110	16,27	705454	6	300	12	70	250
598112	17,36	705478	6	350	15	75	300

BENDING WRENCH

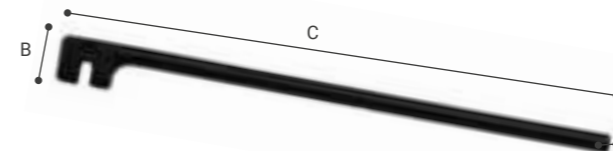

▶ BENDING WRENCH 5985

REF.	€	8 41 4299	g	A mm	B mm	C mm	
5985-8	18,17	157901	6	450	12	31	390
5985-10	20,06	157079	6	820	15	37	456
5985-12	22,88	157062	6	870	15	38	495
5985-14	27,64	157055	6	1.810	20	50	595
5985-16	34,72	157048	10	2.090	20	50	700
5985-18	41,40	157031	6	2.500	20	50	855
5985-20	52,07	157024	6	2.880	20	50	997
5985-22	67,56	157017	4	5.040	25	62	1.094

SCRAPERS AND RAKES

- Made with special Bellota steel.
- Forged in one single piece, unbreakable.
- 3+ steel treatment for a longer tool life: doesn't break, warp or wear away.
- Epoxy coating to prevent rust on tool.

Uses:

- Scrapers and rakes: for moving and spreading cement, concrete, sand, stones, etc.

SCRAPERS

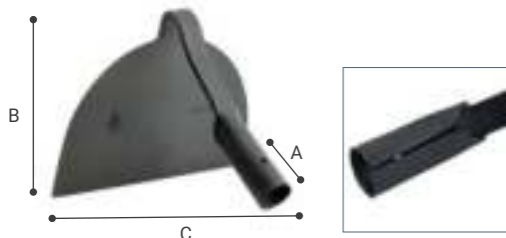

► CURVED SHOULDER SCRAPER 5701

REF.	€	8 41 4299	g	A mm	B mm	C mm
5701-0	36,12	126402	6	1.190	185	258
5701-B	43,09	126600	6	1.290	190	300



► CURVED SHOULDER SCRAPER 5702

REF.	€	8 41 4299	g	A mm	B mm	C mm	M
SCR5702AP	26,86	704990	6	1.310	65	264	230



► SQUARE SHOULDER SCRAPER 5709

REF.	€	8 41 4299	g	A mm	B mm	C mm
5709	48,88	127003	6	1.146	135	305

RAKES

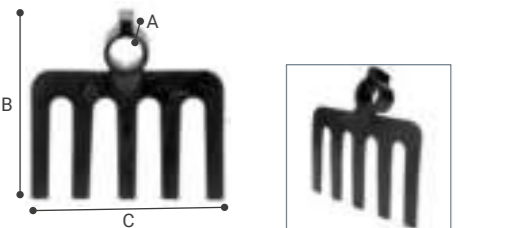

► 5 FLAT PRONG RAKE PRK5751P

REF.	€	8 41 4299	g	A mm	B mm	C mm	M
PRK5751P	35,25	699388	6	1.520	40	235	225



► 5-POINT RAKE PRK5753P

REF.	€	8 41 4299	g	A mm	B mm	C mm	M
PRK5753BP	31,59	696653	6	1.320	45	200	230



► 6 PRONG RAKE PRK5754P

REF.	€	8 41 4299	g	A mm	B mm	C mm	M
PRK5754P	36,57	699364	6	1.430	35	220	230

NIPPERS

- Made with special Bellota steel.
- Forged in one single piece, unbreakable.
- 3+ steel treatment for a longer tool life: doesn't break, warp or wear away.
- Perfect edge alignment for clean cutting.
- Epoxy coating to prevent rust on tool.

Uses:

- For formwork or carpentry work.

CONCRETE'S NIPPER

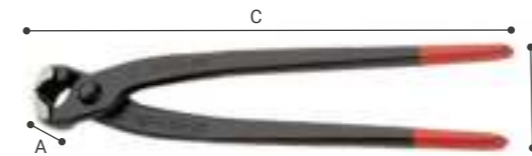

► CONCRETE'S NIPPER 6001

REF.	€	8 41 4299	g	A mm	B mm	C mm
6001-225	16,56	157604	6	310	22	45
6001-250	17,84	157611	6	390	25	50
6001-280	21,30	157628	6	420	25	50
6001-300	22,28	949711	6	530	25	57

CARPENTER'S NIPPER



► CARPENTER'S NIPPER 6005

REF.	€	8 41 4299	g	A mm	B mm	C mm
6005-180	18,37	157635	6	300	21	50
6005-200	19,23	157642	6	380	25	53
6005-225	21,90	157659	6	410	25	55
6005-250	26,39	157666	6	540	27	57

CERAMIC NIPPER



► STRAIGHT CUTS CERAMIC NIPPER 6003

REF.	€	8 41 4299	g	A mm	B mm	C mm
6003	18,17	628982	6	360	57	25

For ceramic tiles to go over straight cuts.



► INNER HOLES CUTS CERAMIC NIPPER 6004

REF.	€	8 41 4299	g	A mm	B mm	C mm
6004	18,17	629002	6	240	55	13

For ceramic tiles to go over inner holes.

BOLT CUTTERS

- Forged in one single piece, unbreakable.
- 3+ steel treatment for a longer tool life: doesn't break, warp or wear away.
- Anti-slip elastomer grips to prevent slippage when being used.
- Epoxy coating to prevent rust on tool.

Uses:

- For cutting steel rods.

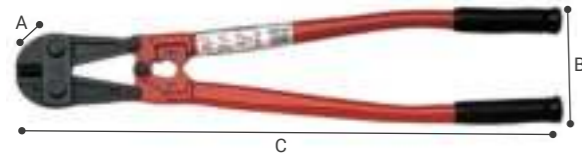

▶ BOLT CUTTER 6009

REF.	€	8 41 4299	g	A mm	B mm	C mm
6009-450	97,33	159011	1 1.550	35	125	472
6009-600	110,69	159028	1 2.600	40	146	627
6009-750	144,12	159035	1 4.010	45	150	780
6009-900	183,29	159042	1 6.110	50	160	930
6009-1050	238,38	159059	1 8.940	55	202	1.070



▶ MINI ROD CUTTER 26009

REF.	€	8 41 4299	g	A mm	B mm	C mm
26009-300	20,31	699630	1 700	310	52	18
26009-350	25,40	699654	1 810	365	60	19

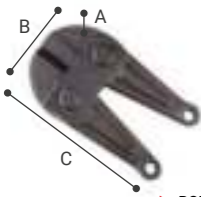

▶ BOLT CUTTER HEAD 6009

REF.	€	8 41 4299	g	A mm	B mm	C mm
C 6009-450	55,22	158960	3 1.000	35	70	130
C 6009-600	75,52	158977	3 2.510	40	85	148
C 6009-750	89,53	158984	1 1.430	45	95	165
C 6009-900	106,60	158991	1 2.080	50	110	186
C 6009-1050	138,86	159004	1 2.910	60	122	210



▶ BOLT CUTTER HEAD SCREW 6009

REF.	€	8 41 4299	g	A mm	B mm	C mm
T 6009-450 M	5,33	179569	100 10	11	21	27
T 6009-600 M	5,33	179576	100 30	13	13	30
T 6009-750 M	5,33	179606	100 30	15	15	40
T 6009-900 M	5,33	179620	100 60	12	12	43
T 6009-1050 M	5,33	179637	100 80	20	20	45
T 6009-450 C	5,33	179477	1 40	17	17	36
T 6009-600 C	5,33	179484	1 60	19	19	40
T 6009-750 C	5,33	179514	1 90	21	21	45
T 6009-900 C	5,33	179521	100 130	25	25	50
T 6009-1050 C	5,33	179538	100 190	28	28	57

M: handle
C: head

LENGTH

Material to be cut	450 mm 19"	600 mm 24"	750 mm 30"	900 mm 36"	1.050 mm 24"
Soft wire 50 kgs/mm ²	Ø 8 mm	Ø10 mm	Ø 13 mm	Ø 16 mm	Ø 19 mm
Hard wire 133 kgs/mm ² HRC-41	Ø 6 mm	Ø 8 mm	Ø 9 mm	Ø 10 mm	Ø 11 mm
Extra hard wire 50 kgs/mm ² HRC-48	Ø 5,5 mm	Ø 7 mm	Ø 8 mm	Ø 9 mm	Ø 10 mm

ORDER

TOOL HOLDER

- High quality tool holder with closed rivets and reinforced seams, long lasting and strong.
- Adjustable to fit any waist and with capacity for whatever you need.
- Two types:
 - High quality split leather
 - High quality technical polyester

Uses:

- For construction workers, installers and especially shuttering workers and plasterers.

BAGS AND BACKPACKS

- Made of high quality technical polyester with reinforced seams, very durable and resistant.
- With divisions and compartments for everything you need.

Uses:

- For workers in construction, industry, technical services, installers...

LEATHER TOOL HOLDER



▶ LEATHER HAMMER HOLDER PCMAR

REF.	€	8 41 4299	g	A mm	B mm	C mm
PCMAR	4,35	715224	1 130	70	135	180



▶ LEATHER TOOL BELT WITH 3 POUCHES PC3BOL

REF.	€	8 41 4299	g	A mm	B mm	C mm
PC3BOL	7,61	715309	1 318	70	225	215



▶ LEATHER TOOL BELT WITH 6 POCKETS PC6BOL

REF.	€	8 41 4299	g	A mm	B mm	C mm
PC6BOL	18,64	715323	1 545	70	550	215



▶ LEATHER TOOL BAG WITH 4 POCKETS PC4BOL

REF.	€	8 41 4299	g	A mm	B mm	C mm
PC4BOL	9,88	715347	1 345	80	320	300



▶ CARTRIDGE BELT 51308

REF.	€	8 41 4299	g	A mm	B mm	C mm
51308	42,66	162271	2 683	50	575	230

Made in leather with heavy duty rivets. Long life and maximum resistance. Four pockets and hammer holder.



▶ TOOL BELT 51320

REF.	€	8 41 4299	g	A mm	B mm	C mm
51320	47,97	561678	3 753	40	1.300	225

High quality leather with heavy duty rivets. Nylon belt with reinforced holes and metal buckle. 5 pockets to hold different types of screws and rivets. Special reinforced pocket to hold aviations snips

TEXTILE TOOL HOLDER



▶ TOOL HOLDER PNT00L

REF.	€	8 41 4299	g	A mm	B mm	C mm
PNT00L	4,59	011722	1 200	40	230	165



▶ FLEXOMETER HOLDER PNFLEX

REF.	€	8 41 4299	g	A mm	B mm	C mm
PNFLEX	3,29	715446	1 66	55	120	160



▶ CUTTER HOLDER PNCUT

REF.	€	8 41 4299	g	A mm	B mm	C mm
PNCUT	3,24	715248	1 78	20	135	190



▶ DRILL HOLDER PNTALAD

REF.	€	8 41 4299	g	A mm	B mm	C mm
PNTALAD	16,75	715361	1 265	90	165	345



▶ BELT PNCIN

REF.	€	8 41 4299	g	A mm	B mm	C mm
PNCIN	3,40	715385	1 115	15	140	60



▶ TOOL BELT WITH 4 POCKETS PN4BOL

REF.	€	8 41 4299	g	A mm	B mm	C mm
PN4BOL	7,61	715262	1 332	80	235	280



▶ TOOL BELT WITH 7 POCKETS PN7BOL

REF.	€	8 41 4299	g	A mm	B mm	C mm
PN7BOL	14,94	715286	1 545	80	600	250

BAGS, BACKPACKS AND TROLLEYS



▶ TOOL BAG BN

REF.	€	8 41 4299	g	A mm	B mm	C mm
BN35	8,37	715408	1 765	230	310	260
BN45	12,92	715422	1 970	230	430	265



▶ 30 CM OPEN BAG BN30A

REF.	€	8 41 4299	g	A mm	B mm	C mm
BN30A	52,79	011760	4 1.360	200	320	260



▶ 45 CM FLAT TOP BAG BN45P

REF.	€	8 41 4299	g	A mm	B mm	C mm
BN45P	58,00	011807	4 1.630	250	440	260



▶ 35 L WHEELED BACKPACK MN35R

REF.	€	8 41 4299	g	A mm	B mm	C mm
MN35R	75,45	011845	6 2.400	250	360	540



▶ 20 L BACKPACK MN20

REF.	€	8 41 4299	g	A mm	B mm	C mm
MN20	71,10	011883	6 1.670	185	305	475



▶ 32L TROLLEY TR32

REF.	€	8 41 4299	g	A mm	B mm	C mm
TR32	119,97	011920	2 4.910	250	430	380

TOOL CASE



▶ TOOL CASE 6900

REF.	€	8 41 4299	g	A mm	B mm	C mm
6900-400	45,12	057133	1 3.240	200	415	230
6900-500	48,97	057140	1 3.680	200	510	230



▶ TOOL CASE 6902

REF.	€	8 41 4299	g	A mm	B mm	C mm
6902-500	86,26	057157	1 4.740	200	505	280

TROWELS

Conical blade:
Thickness adapted so
that the blade bends
perfectly

Ref. 5842-H BIM



Withstands 600 Kg.

Forged in one single piece,
unbreakable



TROWELS

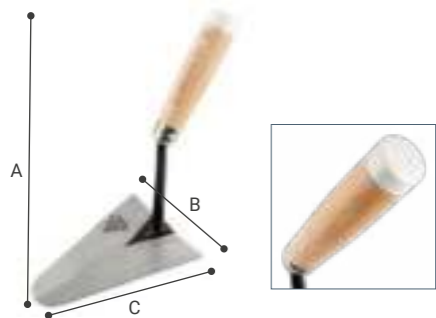

▶ WOODEN HANDLE TROWEL WITH BLOCK TRF41BPB

REF.	€	8 41 4299	g	A mm	B mm	C mm	L mm
TRF41BPB	23,35	690590	6	420	250	120	320 165



▶ BIMATERIAL HANDLE TROWEL TRF42BM

REF.	€	8 41 4299	g	A mm	B mm	C mm	L mm
TRF42HPB	21,75	690613	6	320	110	103	318 190



▶ TROWEL 5841

REF.	€	8 41 4299	g	A mm	B mm	C mm	L mm
5841-A	23,62	131208	6	400	235	115	310 150
5841-B	22,88	131307	6	410	235	120	320 165
5841-C	23,21	131406	6	460	235	125	325 180

Catalan Model.



▶ TROWEL 5842

REF.	€	8 41 4299	g	A mm	B mm	C mm	L mm
5842-B	19,00	131604	6	170	90	67	235 115
5842-D	19,99	131802	6	210	100	80	255 140
5842-F	19,88	132007	6	210	100	91	280 165
5842-H	21,17	132205	6	320	105	103	318 190
5842-J	22,93	132403	6	340	105	115	342 215
5842-K	23,92	155228	6	380	105	121	350 227
5842-L	24,20	132601	6	400	105	127	365 240

Madrid Model.



▶ BIMATERIAL HANDLE TROWEL TRF41BM

REF.	€	8 41 4299	g	A mm	B mm	C mm	L mm
TRF41ABM	25,17	695748	6	400	240	114	325 150
TRF41BBM	25,05	695809	6	455	240	119	330 165
TRF41CBM	25,64	695786	6	470	240	123	340 180



▶ BIMATERIAL HANDLE TROWEL TRF42BM

REF.	€	8 41 4299	g	A mm	B mm	C mm	L mm
TRF42FBM	22,30	695823	6	280	110	91	295 165
TRF42HBM	23,53	695847	6	330	115	102	330 190
TRF42JBM	25,17	695861	6	360	115	115	345 215
TRF42KBM	25,77	695885	6	380	115	120	360 227
TRF42LBM	26,11	695908	6	380	115	127	380 240



▶ TROWEL 5843

REF.	€	8 41 4299	g	A mm	B mm	C mm	L mm
5843-A	25,92	132700	6	400	100	110	310 180
5843-C	26,78	132908	6	420	100	118	330 200

Andalucia Model.



▶ BIMATERIAL HANDLE TROWEL TRF43BM

REF.	€	8 41 4299	g	A mm	B mm	C mm	L mm
TRF43ABM	27,47	699883	6	430	110	110	320 180
TRF43CBM	27,57	699906	6	430	115	118	340 200



▶ TROWEL 5844

REF.	€	8 41 4299	g	A mm	B mm	C mm	L mm
5844-A	25,44	133004	6	430	160	115	320 180
5844-B	25,44	133103	6	480	160	130	320 180
5844-C	26,65	133202	6	460	170	117	325 190

Andalucia Model.



▶ BIMATERIAL HANDLE TROWEL TRF44BM

REF.	€	8 41 4299	g	A mm	B mm	C mm	L mm
TRF44ABM	27,06	695922	6	470	175	115	292 180
TRF44BBM	27,06	695946	6	510	175	130	292 180
TRF44CBM	27,65	695960	6	520	180	117	340 190



▶ WOODEN HANDLE TROWEL WITH BLOCK TRF44BM

REF.	€	8 41 4299	g	A mm	B mm	C mm	L mm
TRF44APB	25,80	690637	6	450	175	115	287 180



▶ TROWEL 5850

REF.	€	8 41 4299	g	A mm	B mm	C mm	L mm
5850-B	28,91	133370	6	360	70	110	370 240

Portuguese Model.



▶ TROWEL 5848

REF.	€	8 41 4299	g	A mm	B mm	C mm	L mm
5848	23,97	236972	6	367	175	110	278 120

Rounded point trowel special for tiling. Special handle for striking tiles.



▶ BIMATERIAL HANDLE TROWEL TRF48BM

REF.	€	8 41 4299	g	A mm	B mm	C mm	L mm
TRF48BM	24,92	695984	6	400	175	110	280 120



▶ TROWEL 5849

REF.	€	8 41 4299	g	A mm	B mm	C mm	L mm
5849	23,97	906394	6	458	180	110	280 120

Square point trowel special for tiling. Special handle for striking tiles.



▶ BIMATERIAL HANDLE TROWEL TRF49BM

REF.	€	8 41 4299	g	A mm	B mm	C mm	L mm
TRF49BM	24,92	696004	6	350	180	110	280 120

FOR CONSTRUCTION



▶ TROWEL 5851

REF.	€	8 41 4299	g	A mm	B mm	C mm	L mm
5851-B	29,54	133400	6	320	75	110	215
5851-C	29,99	133509	6	330	75	115	230
5851-D	30,54	133608	6	390	75	120	240
5851-E	30,91	133615	6	450	75	130	255

Portuguese Model.



▶ TROWEL 5857

REF.	€	8 41 4299	g	A mm	B mm	C mm	L mm
5857-8	20,92	160321	6	275	318	90	200
5857-85	21,11	908657	6	320	338	96	220
5857-7	20,51	136654	6	260	290	81	180
5857-95	21,37	908732	6	365	348	106	240

Trowel Greek.



▶ BIMATERIAL HANDLE TROWEL TRF14BM

REF.	€	8 41 4299	g	A mm	B mm	C mm	L mm
TRF14ABM	24,54	696141	6	490	130	125	180



▶ BIMATERIAL HANDLE TROWEL 5919

REF.	€	8 41 4299	g	A mm	B mm	C mm	L mm
5919-14 CC BIM	22,87	624120	6	310	125	82	140
5919-16 CC BIM	22,87	624144	6	330	130	88	160
5919-18 CC BIM	22,87	624168	6	320	130	95	180

Special for Plastering.



▶ BIMATERIAL HANDLE TROWEL 5904

REF.	€	8 41 4299	g	A mm	B mm	C mm	L mm
5904-14 CC BIM	18,79	624069	6	180	94,9	50	140
5904-16 CC BIM	19,09	624083	6	170	95	50	160
5904-18 CC BIM	20,31	624106	6	190	95	50	180

For finishing and light duty masonry works



▶ BIMATERIAL HANDLE TROWEL TRF51BM

REF.	€	8 41 4299	g	A mm	B mm	C mm	L mm
TRF51BBM	30,29	696028	6	330	85	110	215
TRF51CBM	30,62	696042	6	410	85	115	230
TRF51DBM	31,41	696066	6	380	85	120	240
TRF51EBM	31,58	696080	6	420	85	130	255



▶ BIMATERIAL HANDLE TROWEL TRF57BM

REF.	€	8 41 4299	g	A mm	B mm	C mm	L mm
TRF57ABM	23,26	696103	6	275	95	90	200
TRF57BBM	23,47	696127	6	320	95	96	220



▶ BIMATERIAL HANDLE TROWEL 5915

REF.	€	8 41 4299	g	A mm	B mm	C mm	L mm
5915-17 CC BIM	24,08	624021	6	420	130	120	170

Special for tiling.



▶ TROWEL WITH BI-MATERIAL HANDLE TRF21BM

REF.	€	8 41 4299	g	A mm	B mm	C mm	L mm
TRF21BBM	23,63	696301	6	480	130	125	180

POINTING TROWELS



▶ POINTING TROWEL 5901

REF.	€	8 41 4299	g	A mm	B mm	C mm	L mm
5901-A	20,61	134902	6	170	95	70	125
5901-B	23,54	135008	6	170	95	100	150

For finishing and light duty masonry works



▶ POINTING TROWEL 5902

REF.	€	8 41 4299	g	A mm	B mm	C mm	L mm
5902	19,99	135107	6	183	93	60	135

For finishing and light duty masonry works



▶ POINTING TROWEL 5903

REF.	€	8 41 4299	g	A mm	B mm	C mm	L mm
5903	20,61	135206	6	203	90	75	125

For finishing and light duty masonry works



▶ BIMATERIAL HANDLE POINTING TROWEL TRF01BM

REF.	€	8 41 4299	g	A mm	B mm	C mm	L mm
TRF01BM	20,66	696387	6	170	95	70	125

For finishing and light duty masonry works.



▶ BIMATERIAL HANDLE POINTING TROWEL TRF02BM

REF.	€	8 41 4299	g	A mm	B mm	C mm	L mm
TRF02BM	21,73	696400	6	180	95	60	135

For finishing and light duty masonry works.



▶ BIMATERIAL HANDLE POINTING TROWEL TRF03BM

REF.	€	8 41 4299	g	A mm	B mm	C mm	L mm
TRF03BM	21,73	696424	6	180	90	76	125

For finishing and light duty masonry works.

REPOINTER



▶ BIMATERIAL HANDLE POINTING TROWEL 5913

REF.	€	8 41 4299	g	A mm	B mm	C mm	L mm
5913-06 BIM	9,14	623680	6	110	95	6	288
5913-08 BIM	9,23	623703	6	120	90	8	290
5913-10 BIM	9,69	623727	6	120	90	10	289
5913-12 BIM	10,17	623741	6	170	100	12	315

* AVAILABLE UNTIL END OF STOCK.



▶ POINTING TROWEL 5897

REF.	€	8 41 4299	g	A mm	B mm	C mm	L mm
5897-6	7,21	134285	6	100	90	30	299
5897-8	7,29	134889	6	110	95	30	300
5897-10	7,66	134957	6	100	85	30	302
5897-12	7,86	124989	6	140	90	30	310



TROWELS, FLOATS, SCRAPERS AND SPATULAS

PLASTERING TROWELS

- Made with special Bellota steel.
- 3+ steel treatment for a longer tool life: doesn't break, warp or wear away.
- Very light and ergonomic handles: handle designed to adapt user's hand. For both left and right handed users.
- Two types of handles:
 - Very light and pleasant to touch ergonomic poplar handle.
 - Dual-material ergonomic handles with SOFT TOUCH for comfort during work.
- Perfect Noint and fat Flades.
- Epoxy coating to prevent rust on tool.

Uses:

- For finishing work.
- For spreading and smoothing materials such as cement, mortar and plaster, etc.

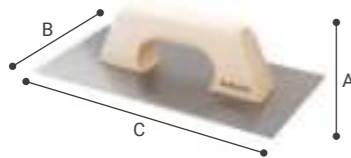

► SQUARE PLASTERING TROWEL 5861

REF.	€	8 41 4299	g	A mm	B mm	C mm
5861-00	12,00	133707	6	370	75	135
5861-0	12,00	133806	6	360	75	120
5861-1	12,25	133905	6	510	75	150
5861-2	12,42	134001	6	430	75	160
5861-3	13,06	134100	6	460	75	180



► BIMATERIAL HANDLE SQUARE PLASTERING TROWEL 5861

REF.	€	8 41 4299	g	A mm	B mm	C mm
5861-00 BIM	12,53	547160	6	380	75	135
5861-0 BIM	12,53	547184	6	370	75	120
5861-1 BIM	13,06	547207	6	420	75	150
5861-2 BIM	14,00	547221	6	430	75	160
5861-3 BIM	14,19	547245	6	460	75	180



► STAINLESS STEEL SQUARE PLASTERING TROWEL 5861

REF.	€	8 41 4299	g	A mm	B mm	C mm
5861-1 INOX	13,27	663037	6	410	75	150



► BIMATERIAL HANDLE STAINLESS STEEL SQUARE PLASTERING TROWEL 5861

REF.	€	8 41 4299	g	A mm	B mm	C mm
5861-1 BIM INOX	14,03	547269	6	410	75	150



► SHARPENED EDGES STAINLESS STEEL SQUARE PLASTERING TROWEL 5861

REF.	€	8 41 4299	g	A mm	B mm	C mm
5861-1 A INOX	15,80	592146	6	420	75	150



► BIMATERIAL HANDLE ROUNDED PLASTERING TROWEL 5863

REF.	€	8 41 4299	g	A mm	B mm	C mm
5863 BIM	13,42	547306	6	410	75	150



► BIMATERIAL HANDLE SHARPENED EDGES STAINLESS STEEL SQUARE PLASTERING TROWEL 5861

REF.	€	8 41 4299	g	A mm	B mm	C mm
5861-1 A BIM INOX	17,44	592160	6	410	75	150



► BIMATERIAL HANDLE SQUARE PLASTERING TROWEL 5864

REF.	€	8 41 4299	g	A mm	B mm	C mm
5864 BIM	13,92	597950	6	340	85	130



► TRAPEZOIDAL PLASTERING TROWEL 5862

REF.	€	8 41 4299	g	A mm	B mm	C mm
5862	13,68	134209	6	444	75	180



► BIMATERIAL HANDLE TRAPEZOIDAL PLASTERING TROWEL 5862

REF.	€	8 41 4299	g	A mm	B mm	C mm
5862 BIM	15,08	547283	6	440	75	180



► ROUNDED PLASTERING TROWEL 5863

REF.	€	8 41 4299	g	A mm	B mm	C mm
5863	12,41	134308	6	450	75	150



► LONG PLASTERING TROWEL 5865

REF.	€	8 41 4299	g	A mm	B mm	C mm
5865	19,06	663075	6	806	75	150



► BIMATERIAL HANDLE STAINLESS STEEL SQUARE PLASTERING TROWEL 5864

REF.	€	8 41 4299	g	A mm	B mm	C mm
5864 BIM INOX	14,57	597974	6	340	85	130



► PLASTIC HANDLE SQUARE PLASTERING TROWEL 25864

REF.	€	8 41 4299	g	A mm	B mm	C mm
25864	5,37	636529	6	297	85	130



► PLASTIC HANDLE STAINLESS STEEL SQUARE PLASTERING TROWEL 25864

REF.	€	8 41 4299	g	A mm	B mm	C mm
25864 INOX	5,76	636543	6	300	85	130



► STAINLESS STEEL LONG PLASTERING TROWEL 5865

REF.	€	8 41 4299	g	A mm	B mm	C mm
5865 INOX	21,24	663112	6	810	75	150



► STAINLESS STEEL FINISHING TROWEL FOR STUCCO WORK OR MICROCEMENT 587003

REF.	€	8 41 4299	g	A mm	B mm	C mm
587003I	57,92	679137	6	460	87	110



► LEVELLING STEEL PLASTERING TROWEL WITH WOODEN HANDLE 5866450

REF.	€	8 41 4299	g	A mm	B mm	C mm
5866450	22,75	045123	6	469	450	105
5866500	27,75	052084	6	523	500	108
5866600	32,75	052916	6	607	600	113



► POLYCARBONATE FINISHING TROWEL FOR STUCCO WORK OR MICROCEMENT 587020

REF.	€	8 41 4299	g	A mm	B mm	C mm
587020P	45,05	679175	6	440	87	110

NEW



► ABS FLEXIBLE PLASTERING TROWEL 5869

REF.	€	8 41 4299	g	A mm	B mm	C mm
5869	9,87	594935	6	264	80	142



► ABS FINISHING TROWEL FOR EXTERIOR INSULATION FINISHING WORK 5869R

REF.	€	8 41 4299	g	A mm	B mm	C mm
5869R	5,58	679106	6	230	85	130



► RENDERING SCRAPER 5880

REF.	€	8 41 4299	g	A mm	B mm	C mm
5880	14,02	554519	6	393	85	135



► BIMATERIAL HANDLE RENDERING SCRAPER 5880

REF.	€	8 41 4299	g	A mm	B mm	C mm
5880 BIM	13,88	554533	6	380	80	135



► SCRAPER BLADE FOR SINGLE LAYER MORTAR 5880H

REF.	€	8 41 4299	g	A mm	B mm	C mm
5880H	7,08	024456	6	393	85	135

NEW



► PLASTER SCRAPER 5879

REF.	€	8 41 4299	g	A mm	B mm	C mm
5879	38,18	133479	1	668	95	90

FINISHING FLOATS

- High finishing quality. High-performance cross-linked polyethylene finishing float, up to 1,000m² working life.
- Prevents cracking of worked surfaces.
- Lightweight and comfortable grip. Finishing jobs will be easier with a handle to protect your hands.

Uses:

- Prevents cracking of worked surface.
- For finishing work, surface finishing, grouting or troweling of cement, mortar and other materials.

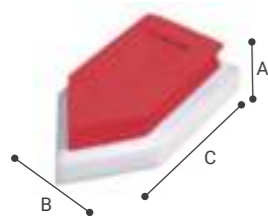

► ANGULAR FINISHING FLOAT 5881PE

REF.	€	8 41 4299	g	A mm	B mm	C mm	L mm
5881PE	11,22	714913	36	31	230	120	50

NEW



► RECTANGULAR FINISHING FLOAT 5883PE

REF.	€	8 41 4299	g	A mm	B mm	C mm	L mm
5883PE	11,22	714937	36	36	230	120	50

NEW

FLOATS

- Top quality dent-proof, polystyrene or polyurethane blade: maximum duration, does not deteriorate.
- Ergonomic and light plastic handle: handle space defined according to user's needs.
- Perfect handle fitting and base flatness.

Uses:

- For finishing tasks.
- To foat or smooth cement, mortar surfaces, etc.

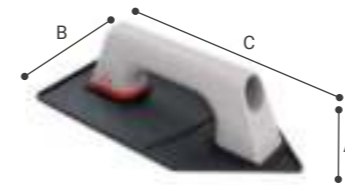

► POINTED FLOAT 5881

REF.	€	8 41 4299	g	A mm	B mm	C mm
5881	8,33	157598	12	230	75	140

Pointed shape, special for corners. Notched Base.



► SQUARE FLOAT 5883

REF.	€	8 41 4299	g	A mm	B mm	C mm
5883	8,63	157581	12	300	76	185

Square Shape. Notched Base.



► BIG SQUARE FLOAT 5885

REF.	€	8 41 4299	g	A mm	B mm	C mm
5885	10,04	157574	12	350	75	220

Square Shape. Notched Base.



► FLAT BASE SQUARE FLOAT 5887

REF.	€	8 41 4299	g	A mm	B mm	C mm
5887	10,04	157567	12	357	75	190

Square Shape. Flat Base.



► LIGHT POINTED FLOAT 5882

REF.	€	8 41 4299	g	A mm	B mm	C mm
5882	6,68	442922	12	185	90	140

Pointed shape, special for corners. Very light.



► LIGHT SQUARE FLOAT 5884

REF.	€	8 41 4299	g	A mm	B mm	C mm
5884	7,09	443318	12	193	95	140

Square Shape. Very light.



► SPONGE FLOAT 5889

REF.	€	8 41 4299	g	A mm	B mm	C mm
5889	11,49	445732	6	439	95	160

Sponge with large cells.

SPECIAL TILING TROWELS

- Made with special Bellota flexible steel.
- 3+ steel treatment for a longer tool life: doesn't break, warp or wear away.
- Very ergonomic handles: handle defined according to the user's needs.
- Two types of handles:
 - VERY light and pleasant to touch ergonomic varnished poplar handle.
 - Bi-material ergonomic handles with SOFT TOUCH for comfort during work.
- Perfect Noint and fat Flades.
- Epoxy varnished blades to prevent rust.

Uses:

- Preparing surfaces for tiling.
- For spreading adhesive to attach ceramic materials.



► V NOTCHED TROWEL 5871

REF.	€	8 41 4299	g	A mm	B mm	C mm
5871-00	13,03	134704	6	360	135	80



► BIMATERIAL HANDLE V NOTCHED TROWEL 5871

REF.	€	8 41 4299	g	A mm	B mm	C mm
5871-00 BIM	13,34	547344	6	360	135	80



► SQUARE NOTCHED TROWEL 5873

REF.	€	8 41 4299	g	A mm	B mm	C mm
5873-03	12,79	663198	6	340	135	80
5873-06	12,39	134803	6	360	135	80
5873-08	12,39	663235	6	340	135	80
5873-10	12,39	663273	6	340	135	80
5873-12	12,79	663358	6	370	135	80
5873-15	12,79	708554	6	360	135	80
5873-20	12,79	708578	6	360	135	80



► BIMATERIAL HANDLE SQUARE NOTCHED TROWEL 5873

REF.	€	8 41 4299	g	A mm	B mm	C mm
5873-03 BIM	13,57	547320	6	360	135	80
5873-06 BIM	13,57	547368	6	360	135	80
5873-08 BIM	13,57	547382	6	350	135	80
5873-10 BIM	13,57	547405	6	360	135	80
5873-12 BIM	13,57	547443	6	350	135	80
5873-15 BIM	13,57	015676	6	360	135	80
5873-20 BIM	13,57	015720	6	360	135	80



► U NOTCHED TROWEL 5873

REF.	€	8 41 4299	g	A mm	B mm	C mm
5873-10R	12,79	663310	6	360	135	80



► BIMATERIAL HANDLE U NOTCHED TROWEL 5873

REF.	€	8 41 4299	g	A mm	B mm	C mm
5873-10R BIM	13,57	547429	6	350	140	80



► BIMATERIAL HANDLE STAINLESS STEEL SQUARE NOTCHED TROWEL 5874

REF.	€	8 41 4299	g	A mm	B mm	C mm
5874-06 BIM INOX	15,20	624526	6	330	130	87
5874-08 BIM INOX	15,20	624540	6	330	130	87
5874-10 BIM INOX	15,20	624564	6	330	130	87
5874-12 BIM INOX	15,20	687002	6	330	130	87



► STAINLESS STEEL SQUARE NOTCHED TROWEL 5874

REF.	€	8 41 4299	g	A mm	B mm	C mm
5874-15 R BIM INOX	15,20	678499	6	330	80	130
5874-10 R BIM INOX	15,20	624588	6	330	80	130



► BIMATERIAL HANDLE U NOTCHED TROWEL 25874

REF.	€	8 41 4299	g	A mm	B mm	C mm
25874-06	5,95	636567	6	290	130	270
25874-10	5,95	636581	6	290	130	270



► LONG SQUARE NOTCHED TROWEL 5875

REF.	€	8 41 4299	g	A mm	B mm	C mm
5875-10	17,65	663396	6	790	135	80
5875-20	17,65	686944	6	650	135	80



► LONG U NOTCHED TROWEL 5875R

REF.	€	8 41 4299	g	A mm	B mm	C mm
5875-10R	17,65	663433	6	760	135	80

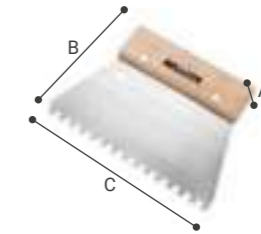

► SQUARE NOTCHED GROUT SPREADER 5877

REF.	€	8 41 4299	g	A mm	B mm	C mm
5877-03	5,26	134605	12	120	125	16
5877-06	5,26	134780	12	120	130	16
5877-08	5,26	134865	12	110	125	16

NOTCHED TROWELS



► LIGHT RUBBER GROUT FLOAT 5898 A

REF.	€	8 41 4299	g	A mm	B mm	C mm
5898 A	12,86	445855	6	220	110	80

EVA Rubber, very flexible and adaptable to all type of surfaces. Very light.



► COMPOUNDED RUBBER GROUT FLOAT 5898 B

REF.	€	8 41 4299	g	A mm	B mm	C mm
5898 B	16,03	445985	6	300	110	80

Very flexible Polyurethane sponge adaptable to all surfaces. Covered by a layer of rubber very resistant to abrasion.



► HARD RUBBER GROUT FLOAT 5898 C

REF.	€	8 41 4299	g	A mm	B mm	C mm
5898 C	14,73	446388	6	500	110	80

Abrasive resistant Rubber, very strong. Ideal for wider joints.

PUTTY KNIVES

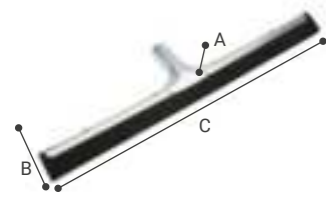

► RUBBER GROUT FLOOR SPREADER 5886F

REF.	€	8 41 4299	g	A mm	B mm	C mm
5886F-45	4,85	629064	12	240	35	450
5886F-60	6,61	629088	12	310	35	600
5886F-75	8,88	699920	12	370	750	35

Very flexible EVA band.



► RUBBER GROUT MANUAL SPREADER 5886W

REF.	€	8 41 4299	g	A mm	B mm	C mm
5886W-20	4,21	629286	12	120	20	200
5886W-30	5,81	629040	12	190	20	300

Top quality Rubber made.

CLEANING FLOATS



► CLEANING FLOAT 5888PE

REF.	€	8 41 4299	g	A mm	B mm	C mm
5888PE	8,49	681970	6	280	280	140



► SPONGE WITH NETTING FOR A BETTER AND EASIER CLEAN-UP.

REF.	€	8 41 4299	g	A mm	B mm	C mm
5888	9,99	135138	6	280	160	100

Sponge with netting for a better and easier clean-up.



► SIMPLE INTERCHANGEABLE CLEANING FLOAT 5810-S

REF.	€	8 41 4299	g	A mm	B mm	C mm
5810-S	9,17	639254	6	320	130	100

Average absorption capacity and durability.



► CLOUD INTERCHANGEABLE CLEANING FLOAT 5810-CL

REF.	€	8 41 4299	g	A mm	B mm	C mm
5810-CL	11,25	639278	6	340	135	100

High absorption capacity and durability. Stays wet longer, makes work easier.



► INTERCHANGEABLE CLEANING FLOAT HANDLE 5810

REF.	€	8 41 4299	g	A mm	B mm	C mm
5810	4,92	639292	6	170	100	75



► SIMPLE BASE FOR INTERCHANGEABLE CLEANING FLOAT 5810B-S

REF.	€	8 41 4299	g	A mm	B mm	C mm
5810B-S	6,05	639315	6	150	130	40

Average absorption capacity and durability.



► CLOUD BASE FOR INTERCHANGEABLE CLEANING FLOAT 5810B-CL

REF.	€	8 41 4299	g	A mm	B mm	C mm
5810B-CL	8,03	639339	6	170	135	30

High absorption capacity and durability. Stays wet longer, makes work easier.



► EPOXY SPONGE FLOAT FLTSP24P

REF.	€	8 41 4299	g	A mm	B mm	C mm
FLTSP24P	16,46	684186	12	295	250	120



► SPARE HARD SPONGE FLOAT SP24HP

REF.	€	8 41 4299	g	A mm	B mm	C mm
SP24SP	7,13	684353	12	125	250	120
SP24MP	7,13	684377	12	150	250	120
SP24HP	7,13	684414	12	200	250	120
SP24XP	7,13	684469	12	155	250	120

White: soft
Red: Medium
Blue: Hard
Tricolour: Mixed

SPECIAL TILIN SPATULAS

- Made with special Bellota steel: maximum durability, does not deteriorate.
- Blades are rectified, aligned and polished to perfect finish.
- Excellent flexibility and comfort when working, which enhances accuracy.
- Two types of handles:
 - Varnished handles, light and pleasant touch wooden handles.
 - Dual-material ergonomic handles with SOFT TOUCH for comfort during work.

Uses:

- For finishing-off tasks.

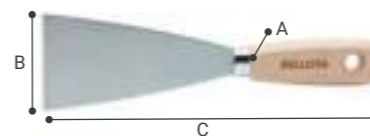

► STEEL PUTTY KNIFE 5890

REF.	€	8 41 4299	g	A mm	B mm	C mm	L mm
5890-30	4,25	098013	12	50	25	30	210
5890-40	4,51	098044	12	50	25	40	210
5890-50	4,76	098075	12	60	25	50	210
5890-60	4,86	098105	12	60	25	60	210
5890-70	5,19	098136	12	70	25	70	210
5890-80	5,36	098167	12	70	25	80	210
5890-100	6,91	098228	12	70	25	100	210



► BIMATERIAL HANDLE STEEL PUTTY KNIFE 5890

REF.	€	8 41 4299	g	A mm	B mm	C mm	L mm
5890-30 BIM	4,49	635089	12	80	25	30	225
5890-40 BIM	4,75	635102	12	80	25	40	225
5890-50 BIM	4,99	635126	12	80	25	50	225
5890-60 BIM	5,27	635140	12	90	25	60	230
5890-70 BIM	5,62	635164	12	90	25	70	230
5890-80 BIM	5,81	635188	12	90	25	80	230
5890-100 BIM	7,25	635201	12	100	25	100	230

▶ **STAINLESS STEEL PUTTY KNIFE 5893**

REF.	€	8 41 4299	g	A mm	B mm	C mm	L mm
5893-40	4,97	120035	12	50	20	40	210
5893-60	5,48	120028	12	60	20	60	210
5893-80	6,07	120042	12	70	20	80	210
5893-100	7,60	120066	12	70	20	100	210

▶ **GROUT SPREADER 5876**

REF.	€	8 41 4299	g	A mm	B mm	C mm	L mm
5876	5,14	134032	12	118	16	180	125

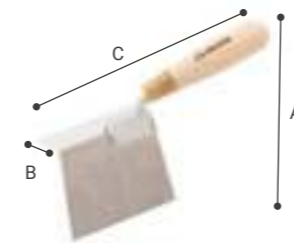
▶ **OUTSIDE CORNER JOINT KNIFE 5896-E**

REF.	€	8 41 4299	g	A mm	B mm	C mm
5896-E	14,86	564525	6	200	110	87

For outside corners.

▶ **INSIDE CORNER JOINT KNIFE 5896-R**

REF.	€	8 41 4299	g	A mm	B mm	C mm
5896-R	14,38	564549	6	230	105	160

For outside corners.

▶ **BIMATERIAL HANDLE STAINLESS STEEL TAPING KNIFE 5899**

REF.	€	8 41 4299	g	A mm	B mm	C mm	L mm
5899-400 BIM	16,03	623789	6	340	15	400	215
5899-500 BIM	18,08	623802	6	400	15	500	215

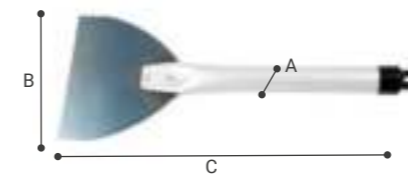
▶ **LIGHT JOINT KNIFE 5896**

REF.	€	8 41 4299	g	A mm	B mm	C mm
5896-180	24,01	561326	6	250	37	177

For review of the tape or removal of the paste after application bazooka.

JOINT KNIVES

Uses:

- Sealing and finishing drywall joints.
- To putty screw heads.

▶ **BIMATERIAL HANDLE JOINT KNIFE 5894**

REF.	€	8 41 4299	g	A mm	B mm	C mm
5894-150 N	13,92	635225	6	180	20	152

Bimaterial handle with aluminium core. High resistance against striking screws.

▶ **BIMATERIAL HANDLE JOINT KNIFE WITH BIT 5894**

REF.	€	8 41 4299	g	A mm	B mm	C mm
5894-150P N	13,69	635249	6	180	20	152

Bimaterial handle with aluminium core with PH2 bit. High resistance against striking screws.

▶ **BIMATERIAL HANDLE TAPING KNIFE 5900**

REF.	€	8 41 4299	g	A mm	B mm	C mm
5900-140	6,32	635263	6	150	20	140
5900-160	6,63	635287	6	170	20	160
5900-180	6,96	635300	6	190	20	180
5900-200	7,30	635324	6	220	20	200

▶ **STAINLESS STEEL TAPING KNIFE 5895**

REF.	€	8 41 4299	g	A mm	B mm	C mm
5895-200	11,16	564440	6	210	20	204
5895-250	12,63	564464	6	260	24	255
5895-300	12,97	564488	6	270	20	305

CAULKING GUNS

- Friction propelled guns, for greater precision.
- Force/effort ratio multiplier by 1:10 in 50262 guns and 1:15 in professional 50264 guns, to maximize the force transmitted during application.
- Steel body for long life and maximum resistance.

Uses:

- Guns for sealants in cartridges or bags of 300 ml.

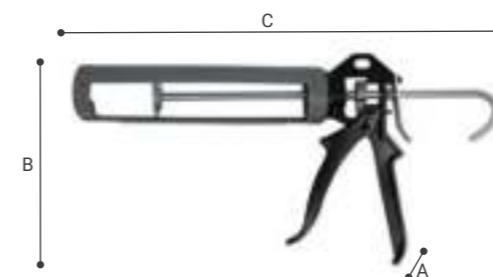
▶ **CAULKING GUN 50262**

REF.	€	8 41 4299	g	A mm	B mm	C mm
50262	8,56	342239	12	646	55	210

For silicon. With anti-drip system.

▶ **PROFESSIONAL CAULKING GUN 50264**

REF.	€	8 41 4299	g	A mm	B mm	C mm
50264	19,48	639094	6	753	60	220

For high viscosity materials: silicon, putties and polyurethane sealants.

HAMMERS AND STRIKING TOOLS



Unbreakable:
Forged in one piece.

They are non-slip, they adapt to you:
Bi-material wooden handles.

SLEDGE HAMMER

• For demolition works.

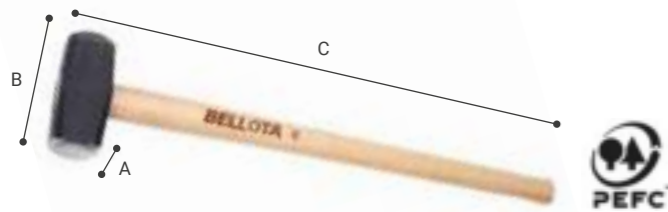

► MALLET 5200

REF.	€	8 41 4299	g	A mm	B mm	C mm	M	Kg
5200-2	38,79	120806	6	2.200	54	125	600	M52002N 1,89
5200-3	46,60	121001	6	3.130	60	140	600	M52003N 2,70 M52004CF
5200-4	56,99	121209	6	4.410	65	156	700	M52004N 3,80 M52004CF
5200-5	68,51	121407	4	5.440	70	170	800	M52005N 4,79 M52006CF
5200-6	79,02	121605	4	6.440	75	180	800	M52006N 5,77 M52006CF
5200-8	97,40	121803	4	8.120	80	195	900	7,27

Beech wood. Perfect join with wedge.



► CARBON FIBER HANDLE SLEDGE HAMMER 5200

REF.	€	8 41 4299	g	A mm	B mm	C mm	M	Kg
5200-3 CF	57,58	625172	6	3.500	60	140	700	M52003N 2,70 M52004CF
5200-4 CF	61,54	625196	6	4.490	65	156	700	M52004N 3,80 M52004CF
5200-5 CF	70,28	625219	4	5.680	70	170	900	M52005N 4,79 M52006CF
5200-6 CF	83,36	625233	4	6.780	75	180	900	M52006N 5,77 M52006CF

Perfect join.



► UNTEMPERED SLEDGE HAMMER WITH CARBON FIBRE HANDLE 5200

REF.	€	8 41 4299	g	A mm	B mm	C mm	M	Kg
5200-3 0 HRc CF	59,57	695496	6	3.500	60	140	700	2,70

PICKS

- Made with special Bellota steel.
- Forged in one single piece, unbreakable.
- 3+ steel treatment for a longer tool life: doesn't break, warp or wear away.
- Epoxy coating to prevent rust on tool.

Uses:

- Pick: for opening trenches and digging stones.

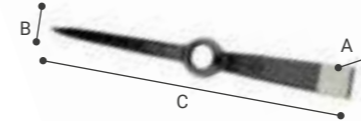

► PICK 5001

REF.	€	8 41 4299	g	A mm	B mm	C mm	M	Kg
5001-A	29,98	120004	6	2.020	65	60	455	M6900 2,05 M6CF M61200 M61400 M6900SB M61200SB
5001-B	29,26	120103	6	2.450	65	60	485	M6900 2,50 M6CF M61200 M61400 M6900SB M61200SB
5001-C	33,80	120202	6	2.970	85	70	530	M6900 3,00 M6CF M61200 M61400 M6900SB M61200SB
5001-D	39,09	120301	6	3.330	85,1	70	575	M6900 3,50 M6CF M61200 M61400 M6900SB M61200SB

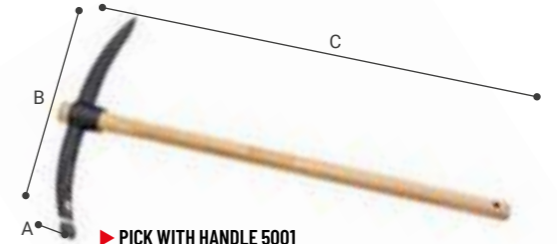

► PICK WITH HANDLE 5001

REF.	€	8 41 4299	g	A mm	B mm	C mm	M	Kg
5001-A CM	42,17	142792	2	2.850	60	465	901	M6900 2,05 M6CF M61200 M61400 M6900SB M61200SB
5001-B CM	42,28	638974	2	3.290	60	495	901	M6900 2,50 M6CF M61200 M61400 M6900SB M61200SB

Eucalyptus wood.



► PICK WITH CARBON FIBER HANDLE 5001

REF.	€	8 41 4299	g	A mm	B mm	C mm	M	Kg
5001-A CF	58,04	638998	2	3.010	60	465	901	M6900 2,05 M6CF M61200 M61400 M6900SB M61200SB
5001-B CF	58,19	639018	2	3.220	60	495	901	M6900 2,50 M6CF M61200 M61400 M6900SB M61200SB



► PICK 5016

REF.	€	8 41 4299	g	A mm	B mm	C mm	M	Kg
5016-00	30,21	182651	6	1.500	45	55	505	M501600 1,50



► PICK WITH HANDLE 5016

REF.	€	8 41 4299	g	A mm	B mm	C mm	M	Kg
5016-00 CM	43,20	225167	6	2.390	55	505	905	M501600 1,50

DRILLING HAMMERS

- For hitting different kinds of construction material and opening up grooves using a chisel or cold chisel.
- New handles design: they are very comfortable, grip well and feel great in your hands.
- New eyes design: oval eyes for maximum comfort when working, avoids the handle turning around.

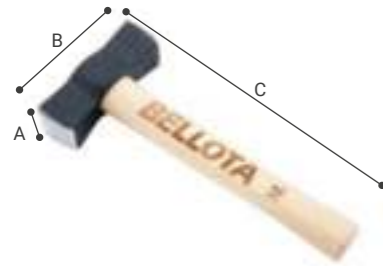

▶ DRILLING HAMMER 5308

REF.	€	8 41 4299	g	A mm	B mm	C mm	M	Kg
5308-0 N	18,44	624731	6	890	45	109	280 M53080N	0,70
5308-A N	20,22	353143	6	1.160	45	125	280 M5308AN	1,00
5308-B N	22,64	353198	6	1.400	49	130	280 M5308BN	1,30

Beech wood. Perfect join with wedge.



▶ CARBON FIBER HANDLE DRILLING HAMMER 5308

REF.	€	8 41 4299	g	A mm	B mm	C mm	M	Kg
5308-0 CF	21,09	625028	6	880	45	109	270 M53080N	0,70
5308-A CF	23,43	625059	6	1.140	45	125	270 M5308AN	1,00
5308-B CF	26,30	625073	6	1.430	49	134	270 M5308BN	1,30

Perfect join.



▶ SQUARE DRILLING HAMMER 5310

REF.	€	8 41 4299	g	A mm	B mm	C mm	M	Kg
5310-A	18,99	661231	6	940	40	88	280 M5308CF	0,80
5310-B	20,83	661316	6	1.190	40	95	280 M5308CF	0,98
5310-C	23,34	661415	6	1.350	43	100	280 M5308CF	1,16
5310-D	25,76	661491	6	1.630	45	110	280 M5308CF	1,50

Beech wood. Perfect join with wedge.



▶ CARBON FIBER HANDLE SQUARE DRILLING HAMMER 5310

REF.	€	8 41 4299	g	A mm	B mm	C mm	M	Kg
5310-A CF	21,69	625097	6	950	40	88	270 M5308CF	0,80
5310-B CF	24,14	625110	6	1.120	40	95	270 M5308CF	0,98
5310-C CF	27,09	625134	6	1.340	43	100	272 M5308CF	1,16
5310-D CF	29,43	625158	6	1.630	45	110	270 M5308CF	1,50

Perfect join.



▶ DRILLING HAMMER 5312

REF.	€	8 41 4299	g	A mm	B mm	C mm	M	Kg
5312-400	22,97	040432	6	1.350	55	170	400 M5312	1,08

Perfect join.



▶ QUARRY DRILLING HAMMER 5305

REF.	€	8 41 4299	g	A mm	B mm	C mm	M	Kg
5305-0	31,06	249163	6	1.070	65	65	235 M5305	1,00
5305-A	33,11	123302	6	1.280	68	68	235 M5305	1,25

Beech wood. Perfect join with wedge.



PICKAXES

- To break up and loosen surfaces.
- New handles design: they are very comfortable, grip well and feel great in your hands.
- New eyes design: oval eyes for maximum comfort when working, avoids the handle turning around.

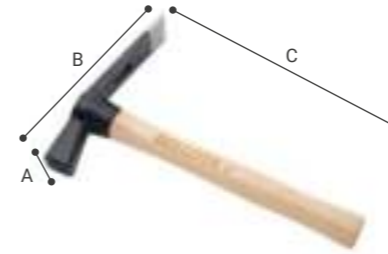

▶ HAMMER-DIGGER PICKAXE 5931

REF.	€	8 41 4299	g	A mm	B mm	C mm	M	Kg
5931-A N	26,18	631777	6	830	45	200	310 M5931AN	0,69
5931-B N	28,86	631814	6	950	50	215	335 M5931BN	0,81

Beech wood. Perfect join with wedge.



▶ CARBON FIBER HANDLE HAMMER-DIGGER PICKAXE 5931

REF.	€	8 41 4299	g	A mm	B mm	C mm	M	Kg
5931-A CF	34,61	631999	6	900	45	200	310	0,81

Perfect join.



▶ HATCHET-DIGGER PICKAXE 5932

REF.	€	8 41 4299	g	A mm	B mm	C mm	M	Kg
5932-00 N	23,68	631852	6	540	38	200	290 M59310N	0,41
5932-0 N	25,24	631876	6	720	39	265	290 M59310N	0,54
5932-A N	25,45	631890	6	800	40	290	310 M5931AN	0,73
5932-B N	29,22	631913	6	1.010	44	315	335 M5931BN	0,84

Beech wood. Perfect join with wedge.



▶ CARBON FIBER HANDLE HATCHET-DIGGER PICKAXE 5932

REF.	€	8 41 4299	g	A mm	B mm	C mm	M	Kg
5932-0 CF	33,31	632019	6	730	38	265	289	0,54
5932-A CF	33,60	632033	6	940	40	290	305	0,73

Perfect join.



▶ PICKAXE 5933

REF.	€	8 41 4299	g	A mm	B mm	C mm	M	Kg
5933-00 N	23,95	631937	6	540	38	210	290 M59310N	0,36
5933-0 N	23,91	631951	6	590	40	270	290 M59310N	0,47
5933-A N	25,66	631975	6	800	41	305	310 M5931AN	0,62

Beech wood. Perfect join with wedge.



▶ CARBON FIBER HANDLE PICKAXE 5933

REF.	€	8 41 4299	g	A mm	B mm	C mm	M	Kg
5933-0 CF	31,49	632057	6	660	40	270	290	0,47
5933-A CF	33,91	632071	6	870	41	305	310	0,62

Perfect join.



▶ SKEPARNI PICKAXE 5938

REF.	€	8 41 4299	g	A mm	B mm	C mm	M	Kg
5938-SM	22,17	999457	12	340	41,5	115,5	30 M5938	0,33

HAMMERS

• For hitting objects, mainly steel or metal sheets; joints, riveting, welded seams and mechanical adjustments in general.



▶ CARPENTER HAMMER 8005

REF.	€	8 41 4299	g	A mm	B mm	C mm	M	Kg
8005-16	13,13	139402	6	130	18	78	250	M800516 0,10
8005-A	11,95	138207	6	190	20	85	280	M8005A 0,14
8005-B	12,11	138504	6	250	23	90	280	M8005B 0,18
8005-C	13,11	138801	6	330	25	100	300	M8005C 0,23
8005-D	14,83	139006	6	430	28	105	300	M8005D 0,32
8005-E	16,13	139105	6	500	30	115	325	M8005E 0,44
8005-F	17,37	139204	6	620	33	120	325	M8005F 0,55

Beech wood. Perfect join with wedge.



▶ CARBON FIBER HANDLE CARPENTER HAMMER 8005

REF.	€	8 41 4299	g	A mm	B mm	C mm	Kg
8005-A CF	18,68	634051	6	250	20	85	270 0,14
8005-B CF	19,49	634075	6	310	23	90	275 0,18
8005-C CF	21,10	634099	6	420	25	100	295 0,23
8005-D CF	22,41	634112	6	510	28	105	295 0,32
8005-E CF	24,40	634136	6	600	30	115	320 0,44

Perfect join.



▶ CLAW HAMMER 8002

REF.	€	8 41 4299	g	A mm	B mm	C mm	M	Kg
8002-13	20,55	363708	6	480	25	120	300	M800213 0,35
8002-16	22,29	611915	6	610	32	130	325	M800216 0,45
8002-20	23,63	611939	6	690	34	135	325	M800220 0,54
8002-24	25,56	611953	6	840	37	150	345	M800224 0,66

Removing nails from 0-1 mm. Beech wood. Perfect join with wedge.



▶ CARBON FIBER HANDLE CLAW HAMMER 8002

REF.	€	8 41 4299	g	A mm	B mm	C mm	Kg
8002-13 CF	24,14	625271	6	550	25	120	300 0,35
8002-16 CF	26,21	625295	6	690	32	130	325 0,45
8002-20 CF	27,77	625318	6	770	34	135	325 0,54
8002-24 CF	30,00	625332	6	920	37	150	336 0,66

Removing nails from 0-1 mm. Perfect join.



▶ CARBON FIBER HANDLE RIP HAMMER 8003

REF.	€	8 41 4299	g	A mm	B mm	C mm	Kg
8003-20 CF	28,35	625356	6	770	31	150	320 0,57

Removing nails from 0-1 mm. Perfect join.



▶ CARBON FIBER HANDLE CARPENTER HAMMER 8006

REF.	€	8 41 4299	g	A mm	B mm	C mm	Kg
8006 CF	30,54	625370	6	780	30	170	325 0,57

Perfect join.



▶ NAIL HAMMER 8007

REF.	€	8 41 4299	g	A mm	B mm	C mm	M	Kg
8007-A	20,16	139600	6	480	38	105	300	M8007A 0,35
8007-B	21,71	139808	6	570	41	115	300	M8007B 0,45
8007-C	22,23	140002	6	670	44	120	335	M8007C 0,54
8007-D	24,38	140101	6	800	47	130	345	M8007D 0,68
8007-E	25,62	140200	6	920	49	135	360	M8007E 0,78
8007-F	29,36	140309	6	1.090	52	142	370	M8007F 0,89

Removing nails from 0-1 mm. Beech wood. Perfect join with wedge. CI: models with magnet.



▶ SHUTTERING HAMMER 8017

REF.	€	8 41 4299	g	A mm	B mm	C mm	M	Kg
8017-0 CI	22,29	458312	6	400	35	122	450	M80170 0,25 M8017A
8017-A CI	22,42	159073	6	450	39	130	450	M8017A 0,31
8017-B	24,45	143102	6	540	42	136	450	M8017B 0,40
8017-C	26,04	143201	6	700	45	150	450	M8017C 0,49
8017-D	29,66	143300	6	840	47	160	450	M8017D 0,59

CI: models with magnet.



▶ SHUTTERING HAMMER 8017

REF.	€	8 41 4299	g	A mm	B mm	C mm	M	Kg
8017-0 CI SM	18,55	466126	12	230	30	35	125	M8030 0,25
8017-A CI SM	19,30	422436	12	280	39	36	130	M8030 0,31

CI: models with magnet.



▶ SHUTTERING HAMMER 8030

REF.	€	8 41 4299	g	A mm	B mm	C mm	M	Kg
8030 CI	26,12	469851	6	860	40	170	450	M8030 0,72 M8030CF

CI: models with magnet.



▶ CARBON FIBER HANDLE SHUTTERING HAMMER WITH MAGNET 8030

REF.	€	8 41 4299	g	A mm	B mm	C mm	M	Kg
8030 CI CF	33,26	439816	6	1.040	40	170	450	M8030 0,72 M8030CF

CI: models with magnet.



▶ AXE-HAMMER 8008

REF.	€	8 41 4299	g	A mm	B mm	C mm	M	Kg
8008	35,54	140408	6	837	30	170	370	M8008 0,57

Beech wood. Perfect join with wedge.



▶ BALL PEEN HAMMER 8011

REF.	€	8 41 4299	g	A mm	B mm	C mm	M	Kg
8011-A	16,27	141009	6	300	25	80	295	M8011A 0,23
8011-B	16,85	141207	6	370	29	90	297	M8011B 0,32
8011-C	17,52	141405	6	520	32	100	319	M8011C 0,42
8011-D	18,95	141603	6	660	34	110	315	M8011D 0,54
8011-E	20,73	141702	6	860	35	120	350	M8011E 0,70
8011-F	22,51	141801	6	1.040	39	129	350	M8011F 0,87
8011-G	24,44	141900	6	1.280	40	137	390	M8011G 1,07
8011-H	27,75	142006	6	1.420	43	145	390	M8011H 1,32

Beech wood. Perfect join with wedge.



▶ CARBON FIBER HANDLE BALL PEEN HAMMER 8011

REF.	€	8 41 4299	g	A mm	B mm	C mm	M	Kg
8011-C CF	29,19	634150	6	630	32	100	310	M8011C 0,42
8011-D CF	31,63	634174	6	760	34	110	315	M8011D 0,54
8011-E CF	34,52	634198	6	970	35	120	345	M8011E 0,70
8011-F CF	37,51	634211	6	1.150	39	129	351	M8011F 0,87
8011-G CF	40,67	634235	6	1.370	40	137	375	M8011G 1,07

Perfect join.



▶ BALL PEEN HAMMER 8009

REF.	€	8 41 4299	g	A mm	B mm	C mm	M	Kg
8009-A	20,83	140507	6	400	27	94	295 M8011B	0,32
8009-B	23,40	140606	6	540	30	105	320 M8011C	0,42
8009-C	23,77	140705	6	660	34	115	320 M8011C	0,54
8009-D	25,67	140804	6	810	36	123	347 M8011E	0,70
8009-E	28,25	140903	6	1.050	39	133	350 M8011F	0,87

Beech wood. Perfect join with wedge.



▶ CARBON FIBER HANDLE BALL PEEN HAMMER 8009

REF.	€	8 41 4299	g	A mm	B mm	C mm	M	Kg
8009-C CF	37,95	639483	6	760	34	115	315 M8011C	0,54
8009-E CF	41,60	639506	6	1.150	39	133	349 M8011E	0,87

Perfect join.



▶ CHIPPING HAMMER 5454

REF.	€	8 41 4299	g	A mm	B mm	C mm	M	Kg
5454-450	18,62	072211	6	590	30	170	325 M8005E	0,45

Beech wood. Perfect join with wedge.



▶ CROSS PEIN GERMAN STYLE HAMMER 2018

REF.	€	8 41 4299	g	A mm	B mm	C mm	Kg
28018B	9,51	705119	6	180	15	82	260 0,10
28018C	10,64	705133	6	300	19	95	280 0,20
28018D	11,20	705157	6	400	23	105	300 0,30
28018F	12,89	705171	6	680	27	118	320 0,50
28018I	17,38	705232	6	1.260	36	135	360 1,00
28018G	14,01	705195	6	700	29	122	330 0,60
28018H	15,70	705218	6	800	33	130	350 0,80

NON-TOUGHENED HAMMERS

- New non-toughened models:
- Recommended for striking hard materials while avoiding breakage.
- MAXIMUM SAFETY. With continued use, the hammer will lose its shape but not its striking capacity, thereby ensuring maximum safety for the user.



▶ CARBON FIBER HANDLE NON-HEAT TREATED DRILLING HAMMER 5308

REF.	€	8 41 4299	g	A mm	B mm	C mm	M	Kg
5308-A 0 HRc CF	24,14	635522	6	1.150	45	125	270 M5308CF	1,00

Perfect join.



▶ CARBON FIBER HANDLE NON-HEAT TREATED BALL PEEN HAMMER 8011

REF.	€	8 41 4299	g	A mm	B mm	C mm	M	Kg
8011-F 0 HRc CF	37,98	635546	6	1.160	39	129	350 0,87	

Perfect join.

NYLON HAMMERS

- For tapping or hitting steel pieces.



▶ NYLON HAMMER 8050

REF.	€	8 41 4299	g	A mm	B mm	C mm	M	Kg
8050-25	15,99	530476	6	250	25	100	270 BB805025	0,19
8050-32	18,58	530513	6	350	32	102	270 BB805032	0,30
8050-38	24,01	530551	6	530	38	110	270 BB805038	0,50
8050-44	33,42	530599	6	770	40	120	315 BB805044	0,63

Beech wood. Perfect join with wedge.



▶ SPARE NYLON HEADS 8050-8051

REF.	€	8 41 4299	g	A mm	B mm	C mm	Kg
BB 8050-25	3,85	531312	12	10	25	20	25 0,00
BB 8050-32	4,82	531350	12	20	32	102	30 0,00
BB 8050-38	5,99	531398	12	20	38	110	36 0,00
BB 8050-44	7,12	531435	12	40	44	120	45 0,00
BB 8050-50	9,20	531473	12	50	50	140	50 0,00
BB 8050-63	12,21	573756	12	70	63	165	65 0,00

RUBBER MALLET

- Head made of top quality resistance isoprene rubber: maximum resistance and durability. Odourless, no crystallization.
- With an excellent bounce that guarantees accuracy and comfort when tapping the tiles into place, as well as the protection of the ceramic material used in the job.
- Varnished Beech handle, light, pleasant touch wooden handles. PEFC certified.

Uses:

- In general, used for tapping things into place.
- Specially, tiling jobs, to adjust the position of the ceramic tiles when they are being laid.



▶ RUBBER MALLET 8053

REF.	€	8 41 4299	g	A mm	B mm	C mm	M	Kg
8053-250	11,19	598179	6	320	100	60	320 M8053250	0,25
8053-500	14,11	598193	6	640	130	80	360 M8053500	0,50
8053-750	18,92	598216	6	890	140	90	360 M8053750	0,75

For general adjustment work and special for tiling jobs.



▶ RUBBER MALLET 8054

REF.	€	8 41 4299	g	A mm	B mm	C mm	M	Kg
8054-250	11,99	598230	6	360	100	60	320 M8053250	0,25
8054-500	14,87	598254	6	640	130	70	360 M8053500	0,50
8054-750	19,86	598278	6	960	140	85	360 M8053750	0,75

For general adjustment work and special for tiling jobs. Special non surface marking.

CHISELS

- Made with special Bellota steel.
- 3+ steel treatment for a longer tool life: doesn't break, warp or wear away.
- Different heat treatments in three areas: head, point and body, no splinters. Maximum safety.
- Ground, bevelled and varnished points.
- Respects the environment.
- Protector with three levels for greater hand protection.

POINT CHISEL

- For opening cracks and breaking in general.
- To remove excess of concrete, cement and other materials from building work.

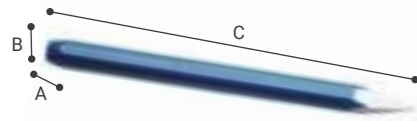

► CLOUD BASE FOR INTERCHANGEABLE CLEANING FLOAT 5810B-CL

REF.	€	8 41 4299	g	A mm	B mm	C mm	L mm
5821-14x200	9,90	127706	6	230	14	14	200
5821-14x250	10,51	127904	6	290	14	14	250
5821-16x200	10,31	128109	6	290	16	16	200
5821-16x250	11,16	128208	6	380	16	16	250
5821-16x300	11,49	128307	6	460	16	16	300
5821-16x350	12,56	128406	6	540	16	16	345
5821-18x250	11,92	128604	6	470	18	18	250
5821-18x300	12,92	128703	6	570	18	18	300
5821-18x350	13,79	128802	6	680	18	18	350
5821-18x400	14,87	128901	6	800	18	18	400



► POINT CHISEL WITH HAND GUARD 5821

REF.	€	8 41 4299	g	A mm	B mm	C mm	L mm
5821-14x250 CP	14,23	037944	6	510	85	100	250
5821-16x250 CP	14,87	038125	6	590	85	100	250
5821-16x300 CP	15,22	038163	6	660	85	100	300
5821-18x250 CP	15,56	038200	6	670	85	100	250
5821-18x300 CP	16,69	038248	6	800	85	100	300
5821-18x350 CP	17,45	038286	6	900	85	100	350
5821-18x400 CP	18,36	360547	6	1.000	85	100	400

CHISEL



► CHISEL 5825

REF.	€	8 41 4299	g	A mm	B mm	C mm	L mm
5825-14x200	9,99	129502	6	240	14	20	200
5825-14x250	10,74	129700	6	300	14	20	250
5825-16x200	10,74	129908	6	310	16	23	200
5825-16x250	11,49	130003	6	390	16	23	250
5825-16x300	11,63	130102	6	470	16	23	300
5825-16x350	12,50	130201	6	560	16	23	350
5825-18x250	12,09	130409	6	480	18	26	250
5825-18x300	13,28	130508	6	590	18	26	300
5825-18x350	14,28	130607	6	710	18	26	350
5825-18x400	15,20	130706	6	790	18	26	400
5825-20x300	14,57	130805	6	740	20	30	300



► CHISEL WITH HAND GUARD 5825

REF.	€	8 41 4299	g	A mm	B mm	C mm	L mm
5825-14x250 CP	14,33	038446	6	510	85	100	250
5825-16x250 CP	14,99	038484	6	600	85	100	250
5825-16x300 CP	15,27	038521	6	680	85	100	300
5825-18x250 CP	15,74	038569	6	700	85	100	250
5825-18x300 CP	16,88	038606	6	800	85	100	300
5825-18x350 CP	17,70	038644	6	900	85	100	350
5825-18x400 CP	18,57	360615	6	1.020	85	100	400

COLD CHISEL



► COLD CHISEL 8251

REF.	€	8 41 4299	g	A mm	B mm	C mm	L mm
8251-150	8,79	660609	6	190	11	20	150
8251-175	9,40	146004	6	180	11	18	175
8251-200	10,21	146103	6	330	12	23	200
8251-225	11,28	146301	6	370	12	22	225
8251-250	12,44	146400	6	490	12	22	250
8251-300	13,66	146509	6	600	12	25	300
8251-350	15,46	146608	6	720	12	25	350
8251-400	17,13	146707	6	810	12	25	400



► COLD CHISEL WITH HAND GUARD 8251

REF.	€	8 41 4299	g	A mm	B mm	C mm	L mm
8251-250 CP	16,13	038804	6	700	85	100	250
8251-300 CP	17,58	038842	6	800	85	100	300
8251-350 CP	19,12	038880	6	960	85	100	350
8251-400 CP	20,89	038927	6	990	85	100	400



► COLD CUTTER GUARD

REF.	€	8 41 4299	g	A mm	B mm	C mm
M8251-25X12BIM	5,40	663341	12	220	98	85

BRICK CHISEL



► BRICK CHISEL 8271

REF.	€	8 41 4299	g	A mm	B mm	C mm	L mm
8271-60	12,07	624816	6	460	13	60	230
8271-70	13,04	037241	6	450	13	70	230
8271-80	15,52	037272	6	540	13	80	230
8271-90	18,58	624847	6	580	13	90	230
8271-100	22,69	624878	6	570	13	100	230

* 8271-90/8271-100: AVAILABLE UNTIL END OF STOCK.



► BRICK CHISEL WITH HAND GUARD 8271

REF.	€	8 41 4299	g	A mm	B mm	C mm	L mm
8271-60 CP	16,87	624908	6	660	85	100	230
8271-80 CP	20,97	624922	6	760	85	100	230

* 8271-100 CP: AVAILABLE UNTIL END OF STOCK.

CHISEL FOR WORKSHOP

- For canal opening, even in areas difficult to reach.
- To remove welds and other debris.



► MECHANIC GRAVER 8241

REF.	€	8 41 4299	g	A mm	B mm	C mm	L mm
8241-175	17,84	145700	6	200	22	11	175
8241-200	19,55	145809	6	300	28	12	200
8241-250	21,56	145908	6	480	25	12	250



► MECHANIC CHISEL 8245

REF.	€	8 41 4299	g	A mm	B mm	C mm	L mm
8245-200	11,07	660647	6	340	12	26	200
8245-250	11,50	660685	6	400	12	26	250
8245-300	12,44	660722	6	610	12	29	300
8245-350	12,55	660760	6	700	12	29	350



► ELECTRICIAN'S CHISEL 8255

REF.	€	8 41 4299	g	A mm	B mm	C mm	L mm
8255-8x200	10,02	660883	6	50	6	8	200
8255-10x200	10,06	660920	6	90	8	10	200
8255-10x250	10,29	660968	6	120	8	10	250
8255-12x200	10,29	661002	6	100	8	12	200
8255-12x250	10,63	661040	6	120	8	12	250
8255-12x300	10,88	661088	6	140	8	12	300



► TINSMITH'S CHISEL 8261

REF.	€	8 41 4299	g	A mm	B mm	C mm	L mm
8261-240	14,86	661125	6	310	7	26	240

MASON PINS

- Made with special Bellota steel.
- Tip with 3+ steel treatment for a longer tool life: doesn't break, warp or wear away.
- Resharpenable tip.
- Non-slip effect on head.

Uses:

- Holds rules for the application of construction materials.

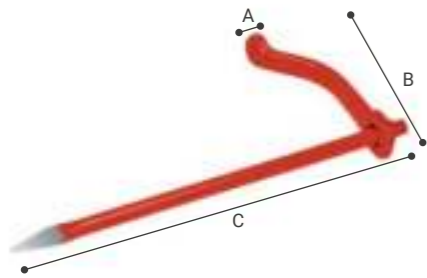

► ROUND PROFILE PLASTER POINTER 8280

REF.	€	8 41 4299	g	A mm	B mm	C mm	L mm
8280-200	4,60	037364	6	240	25	120	200
8280-250	4,57	037395	6	270	25	120	250
8280-300	4,67	037425	6	300	25	120	300



► SQUARE PROFILE PLASTER POINTER 8281

REF.	€	8 41 4299	g	A mm	B mm	C mm	L mm
8281-200	4,72	037494	6	270	25	120	200
8281-250	4,64	037555	6	310	30	120	250
8281-300	5,13	037616	6	310	30	120	300

NEW ELECTRIC MIXER 1,400W

MAIN FEATURES

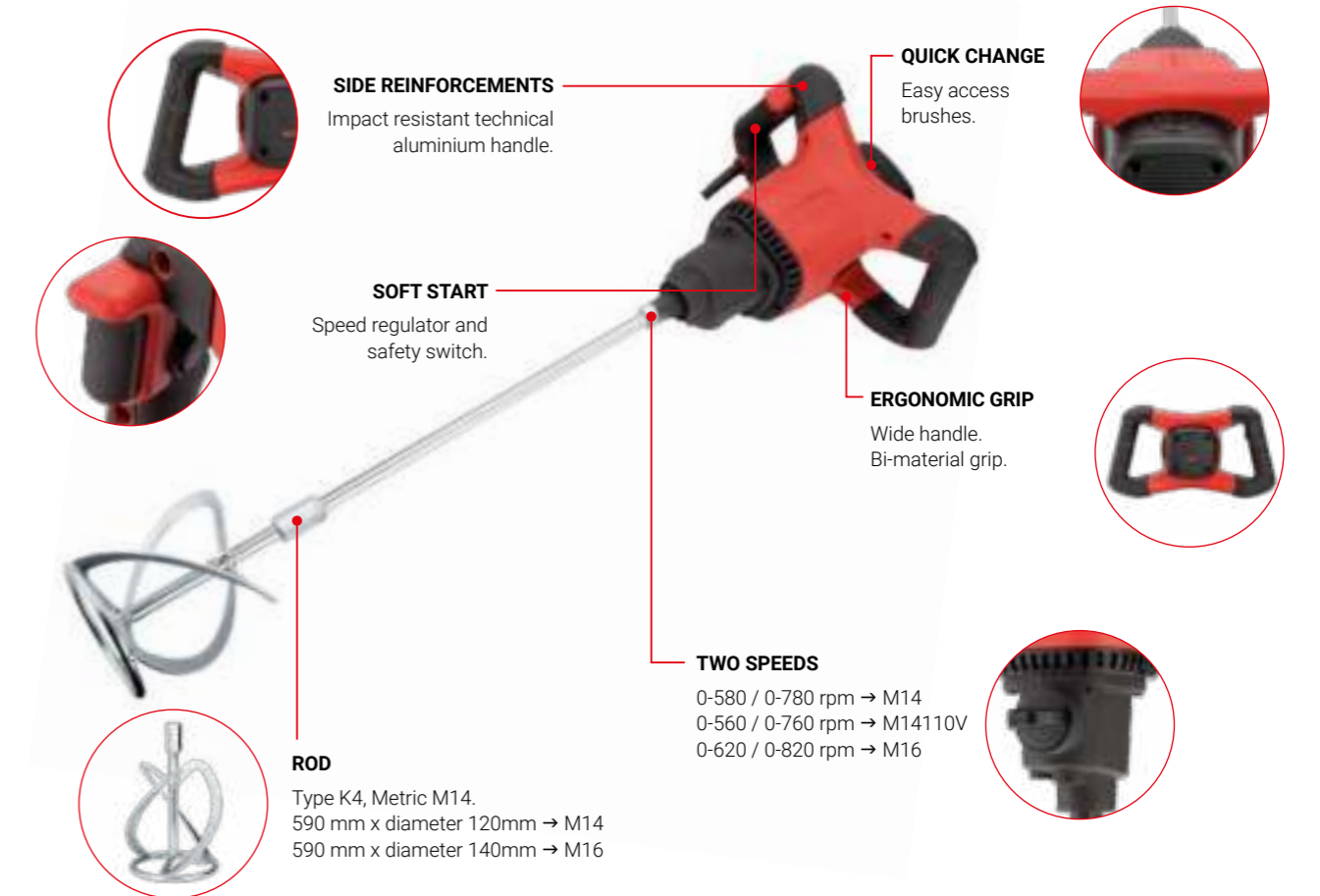

	MCM12LIGHT	MCM12LIGH-T230V	M14	M14110V	M14230V	M16	M18	M18230V	M18CASE	M18230VCASE
Rated voltage (V)	220-240	220-240	230	110	230	230	230	230	230	230
Rated power (W)	1.200	1.200	1.400	1.400	1.400	1.600	1.800	1.800	1.800	1.800
Frequency (Hz)	50	50	50	60	50	50	50	50	50	50
Rated no-load speed (rpm)	0-800	0-800	0-580 0-780	0-560 0-760	0-580 0-780	0-620 0-820	0-440 0-780	0-440 0-780	0-440 0-780	0-440 0-780
Rod	120	120	120	120	120	140	140	140	140	140
Type of socket	F (Euro)	3P	F (Euro)	D (3P)	G	F (Euro)	F (Euro)	G	F (Euro)	G
Cable length (m)	2	2	3	3	3	3	3	3	3	3
Net weight (Kg)	3,45	3,45	4,26	4,26	4,26	4,375	4,75	4,75	4,75	4,75
Max. rod diameter (mm)	120	120	120	120	120	140	140	140	140	140
Mix capacity (L)	40	40	75	75	75	95	110	110	110	110
Plastic case	NO	NO	NO	NO	NO	NO	NO	NO	YES	YES

MIXERS

- Engine with electronic speed setting matching useful power to the material's density and mixture size with the option for a slow start up preventing the mixture uncontrollably splashing outwards.
- Easy to use with the button on the ring allowing the speed to be set without having to constantly press down on the tab and speed selector for easy speed adjustment.
- Bi-material grips sloping at 20° to improve ergonomomy. With SOFT TOUCH, for comfort during work.

Uses:

- For mixing mortar, cement, resin, paints, adhesive, etc.
- 50787: For adhesive mortars, fillers, adhesive cement, rapid mortar, adhesive mortar with fiber.
- 50788: For adhesive mortars, fillers, adhesive cement, rapid mortar.



► MIXER M12LIGHT

REF.	€	8 41 4299	g	A mm	B mm	C mm	
MCM12LIGHT	149,95	607567	1	4.670	225	315	870
MCM12LIGHT230V	149,95	638820	1	4.740	225	315	870

Includes 120mm diameter rod spanner instruction handbook warranty voucher and CE certificate.



NEW

► MIXER M14

REF.	€	8 41 4299	g	A mm	B mm	C mm	
M14	134,95	022292	1	5.385	180	325	890
M14110V	134,95	022490	1	5.385	180	325	890
M14230V	134,95	051940	1	5.385	180	325	890

Mixer rod 2 open-end wrenches 2 brushes user's manual.



NEW

► MIXER M16

REF.	€	8 41 4299	g	A mm	B mm	C mm	
M16	144,95	042719	1	5.680	180	325	890



NEW

► MIXER M18

REF.	€	8 41 4299	g	A mm	B mm	C mm	
M18	186,80	710595	1	6.000	200	350	885
M18CASE	212,05	710618	1	6.000	200	350	885
M18230V	186,80	051995	1	6.000	200	350	885
M18230VCASE	212,05	075533	1	6.000	200	350	885

Mixer rod 2 spanners 2 brushes instruction manual.

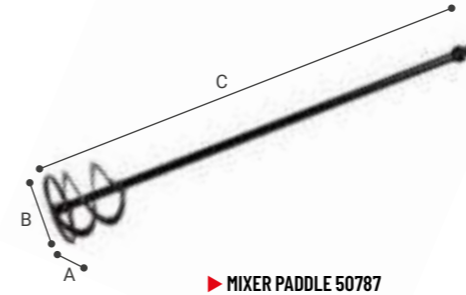

► MIXER PADDLE 50787

REF.	€	8 41 4299	g	A mm	B mm	C mm
50787-70	21,09	282122	6	330	70	492
50787-100	28,76	282252	2	820	95	595
50787-120	31,24	282320	2	990	130	600
50787-140	44,32	282375	2	1.210	138	605



► MIXER PADDLE 50788

REF.	€	8 41 4299	g	A mm	B mm	C mm
50788-85	18,95	282498	6	380	80	496
50788-115	18,93	282566	6	740	90	600



► MIXER PADDLE MK1HEX

REF.	€	8 41 4299	g	A mm	B mm	C mm
MK180HEX8	13,32	022544	16	230	80	400
MK1100HEX10	15,09	022582	16	490	100	590

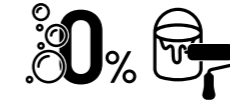

NEW



► MIXER PADDLE MK6HEX

REF.	€	8 41 4299	g	A mm	B mm	C mm
MK6100HEX10	15,55	022728	16	820	100	590



NEW



► MIXER PADDLE MK5M14

REF.	€	8 41 4299	g	A mm	B mm	C mm
MK5120M14	16,43	023022	2	880	120	590



NEW



► MIXER PADDLE MK7M14

REF.	€	8 41 4299	g	A mm	B mm	C mm
MK7120M14	16,43	023237	2	880	120	590



NEW



► MIXER PADDLE MK4M14

REF.	€	8 41 4299	g	A mm	B mm	C mm
MK4120M14	17,41	023381	2	1.070	120	590
MK4140M14	18,77	024272	2	1.190	140	590
MK4160M14	20,13	024388	12	1.290	160	590



NEW

BUCKETS

RUBBER BUCKETS

- Made of durable rubber that provides high capacity to absorb impacts, shocks and falls. High thermal and chemical resistance.
- Reinforced inside and walls so that they do not break or crack.
- Flat industrial rubber bucket that allows walking without hindering the legs, skimming the floor and fitting easily against a ladder.

Uses:

- For demanding jobs: mixing, rubble, water and aggregate transport in agriculture, construction and industry.



▶ ITALIAN RUBBER BUCKET 10L

REF.	€	8 41 4299	g	A mm	B mm	C mm	L
BKC10BM	9,96	006940	1	1.300	370	370	220 10



▶ RUBBER SPOUT BUCKET 11L N2

REF.	€	8 41 4299	g	A mm	B mm	C mm	L
BKCESPU11BP	9,73	007800	1	1.700	400	470	200 11



▶ RUBBER SPOUT BUCKET WITH 4 HANDLES 37L N5

REF.	€	8 41 4299	g	A mm	B mm	C mm	L
BKCESPU37BP	23,19	008296	1	3.500	560	540	380 37



▶ RUBBER TUB 8L

REF.	€	8 41 4299	g	A mm	B mm	C mm	L
BKCGAVE8BP	11,49	047394	5	2.000	364	484	125 8



▶ RUBBER TUB 14L N2

REF.	€	8 41 4299	g	A mm	B mm	C mm	L
BKCGAVE14BP	17,20	008364	10	670	320	340	230 14



▶ RUBBER TUB 15L N2

REF.	€	8 41 4299	g	A mm	B mm	C mm	L
BKCGAVE15BP	17,20	015355	1	2.640	436	546	170 15



▶ RUBBER COAL BUCKET 18L

REF.	€	8 41 4299	g	A mm	B mm	C mm	L
BKCCARB18BP	12,49	047134	5	2.100	420	453	260 18



▶ RUBBER COAL BUCKET 30L N2

REF.	€	8 41 4299	g	A mm	B mm	C mm	L
BKCCARB30BP	17,50	008395	1	3.100	430	470	275 30



▶ INDUSTRIAL RUBBER BUCKET WITH SPOUT 12L N4

REF.	€	8 41 4299	g	A mm	B mm	C mm	L
BKCIND12BM	13,48	015843	1	1.840	320	340	230 12



▶ INDUSTRIAL FLAT RUBBER BUCKET 13L

REF.	€	8 41 4299	g	A mm	B mm	C mm	L
BKCIND13BM	13,83	011708	1	800	320	340	230 13



▶ CANARY BUCKET 18L

REF.	€	8 41 4299	g	A mm	B mm	C mm	L
BKCCAN18BP	12,99	008852	5	2.500	340	441	338 18



▶ NORTHERN RUBBER BUCKET 13L

REF.	€	8 41 4299	g	A mm	B mm	C mm	L
BKCNOR13BP	12,99	047417	5	2.640	452	452	226 13



▶ SPART RUBBER BUCKET 9L

REF.	€	8 41 4299	g	A mm	B mm	C mm	L
BKCSPART9BP	11,49	008456	1	1.500	415	455	240 9

PLASTIC BUCKETS

- Made of top quality 100% recycled polyethylene. Durable, stable, easy to clean and with high thermal and chemical resistance.
- Impact resistant: Highly flexible and lightweight for easy transport and stacking of materials. In addition, the interior and handles are reinforced to prevent breakage.
- Food grade certificate to guarantee fruits and vegetables safety during transportation.

Uses:

- For rubble, water and aggregate transport in agriculture and construction.
- Food grade certificate: fruits and vegetables.



▶ 26L BLACK PLASTIC BUCKET WITH METALLIC HANDLE

REF.	€	8 41 4299	g	A mm	B mm	C mm	L
BKT26BM	4,98	676419	12	660	360	390	26



▶ 26L BLACK PLASTIC BUCKET

REF.	€	8 41 4299	g	A mm	B mm	C mm	L
BKT26BP	4,20	676495	12	540	350	400	26



▶ BLACK PLASTIC BUCKET

REF.	€	8 41 4299	g	A mm	B mm	C mm	L
BKT42BP	5,65	676730	12	980	520	450	42
BKT65BP	9,77	676815	6	1.520	560	615	65



▶ 42L RED PLASTIC BUCKET

REF.	€	8 41 4299	g	A mm	B mm	C mm	L
BKT42RP	6,51	676655	12	980	520	450	42



▶ WHITE PLASTIC BUCKET FOR FOOD USE

REF.	€	8 41 4299	g	A mm	B mm	C mm	L
BKT42WP	10,54	676891	12	890	520	450	42
BKT65WP	15,24	677096	6	1.410	560	615	65



▶ BLUE PLASTIC BUCKET FOR FOOD USE

REF.	€	8 41 4299	g	A mm	B mm	C mm	L
BKT42BLP	10,54	676969	12	890	520	450	42
BKT65BLP	15,24	677010	6	1.420	560	615	65



▶ BUCKET 10L

REF.	€	8 41 4299	g	A mm	B mm	C mm	L
BKW10BM	6,18	678376	12	670	320	340	11



▶ BUCKET 13L

REF.	€	8 41 4299	g	A mm	B mm	C mm	L
BKW13BLM	3,02	680973	24	380	300	310	13
BKW16BLM	4,26	679069	12	630	320	350	16



▶ 30L BLACK PLASTIC BUCKET

REF.	€	8 41 4299	g	A mm	B mm	C mm	L
BKT30BP	5,12	676570	12	630	475	420	30

MUD PAN



▶ MUD PAN 50271

REF.	€	8 41 4299	g	A mm	B mm	C mm	L
50271	26,29	564600	2	591	120	354	2,9

TILE CUTTERS AND ACCESSORIES

1
2
3

- ▶ **A precise cut:**
More stable bases and solid steel guides to guarantee the cut and precision.
- ▶ **Robust:**
Safe tools and ready for intensive use.
- ▶ **Light for carrying:**
Aluminium base for easy transportation. Trolley with wheels for TECH and NEO range.

CHARACTERISTICS

LEAN TILE CUTTER

- ▶ Cuts tiles up to 3.200 mm long and 12 mm thick.
- ▶ Made of strong and durable materials for a long tool life.
- ▶ With scoring indicator accessory, 22mm roller and carrying bag.

NEO TILE CUTTER

- ▶ Cuts up to 1,550 mm and 18 mm thick.
- ▶ Robust and precise single-guide structure with a powerful separation system.
- ▶ Includes wheeled trolley case, square stop, side supports and 22 mm diameter roller.

TECH TILE CUTTER

- ▶ It can cut up to 1.250 mm and thicknesses of 20 mm.
- ▶ Made with heavy-duty materials, patented assembly system and an optimized design to produce an extremely accurate and long-lasting machine.
- ▶ It comes with a case that has rolling wheels, a set square and an 8, 10 or 18 mm XL scoring wheel according to the machine.

PRO TILE CUTTER

- ▶ It can cut up to 720 mm and thicknesses of 15 mm.
- ▶ Ambidextrous single point breaker mechanism incorporated into the ruler stop, gradual and powerful scoring, the force is released into the guide system. It comes with covers designed to stop the tiles getting scratched when they are being cut. Flat base that is easy to clean.
- ▶ It comes with a case, set square and 6 and 10 mm scoring wheels.

FIT TILE CUTTER

- ▶ It can cut up to 1.250 mm long and thicknesses of 15 mm.
- ▶ User-friendly magnetic moving breaker, with up to 600 kg breaking force.
- ▶ It comes with a ruler-set square and an XL 8 mm scoring wheel.

POP TILE CUTTER

- ▶ It can cut lengths up to 630 mm and a thickness of 12 mm.
- ▶ Injected aluminium base with a ribbed central profile, extra wide to guarantee steadiness, stability, precision when scoring. Moving breaker up to 300 kg of force.
- ▶ It comes with a ruler-set square and 6 mm scoring wheel set.

PASS TILE CUTTER

- ▶ It can cut up to 610 mm long and thicknesses of 12 mm.
- ▶ Moving breaker with up to 300 kg of breaking force.
- ▶ It comes with a ruler stop-set square and a 6 mm scoring wheel.

USES

- ▶ For large-format ceramic slabs and thin ceramics up to 12 mm thick.
- ▶ Designed to work with large formats.
- ▶ The best choice for the professional installer with the most demanding needs.
- ▶ For cutting large formats.
- ▶ For professional installer with the most demanding needs.
- ▶ For high intensity work.
- ▶ For tiling jobs where versatility is required.
- ▶ For cutting everyday shapes in paving stones and tiles.
- ▶ For tiling works.

WHAT DO YOU WANT TO DO?



	LEAN	NEO	TECH	PRO	FIT	POP	PASS
Maximum cutting thickness	12 mm	18 mm	20 mm	15 mm	15 mm	12 mm	12 mm
For what cutting length?	3.200 mm	1.550 mm	1.250 mm	720 mm	1.250 mm	630 mm	610 mm
What breaking capacity (enhances separator) do they have?	200 kg	1.200 kg	1.000 kg	500 kg	600 kg	300 kg	300 kg
What scoring wheel do I use?	LEANRUL22	EVORUL22	8XL/10XL/18XL	6/8/10/18	8XL/10XL/18XL	6/8/10/18	6/8/10/18

CHOOSE YOUR SCORING WHEEL



On what materials?	Ø 22 Used on rusting paving, stoneware and rough textured ceramic tiles	Ø 6 Use it on flat shiny surfaces	Ø 8 Use it on flat matt surfaces	Ø 10 Used on matt textured surfaces	Ø 18 Use it on rough textured surfaces
Ceramic	▲	▲▲▲	▲▲	▲▲	
Porcelain	▲▲	▲▲	▲▲▲	▲▲▲	▲▲
Rustic stoneware	▲▲▲				▲▲▲
Stoneware	▲▲▲		▲▲	▲▲▲	▲▲▲
Glass mosaic tiles	▲▲▲	▲▲▲	▲▲		▲▲▲
Rough tile	▲▲▲		▲▲	▲▲▲	▲▲▲

PERFORMANCE OF SCORING WHEELS & TITANIUM SCORING WHEELS

How many metres do they cut?	Ø 22	Ø 6	Ø 8	Ø 10	Ø 18
Normal scoring wheel	3.000 m	1.000 m	1.000 m	2.000 m	2.500 m
Titanium scoring wheel	-	-	1.200 m	2.400 m	3.000 m

+20% PERFORMANCE WITH THE TITANIUM SCORING WHEELS

TILE CUTTERS AND ACCESSORIES

NEO TILE CUTTER

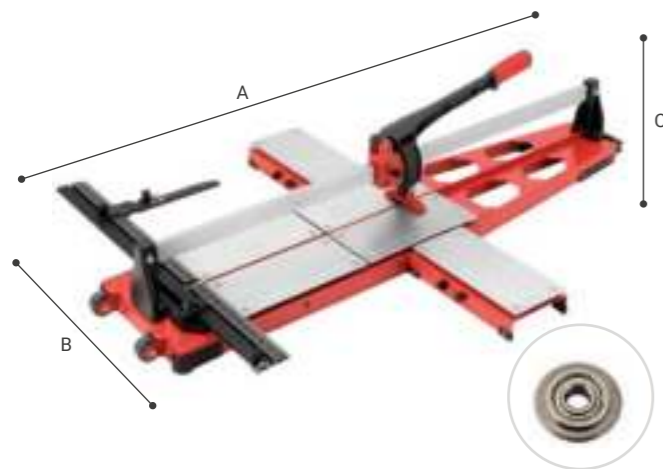
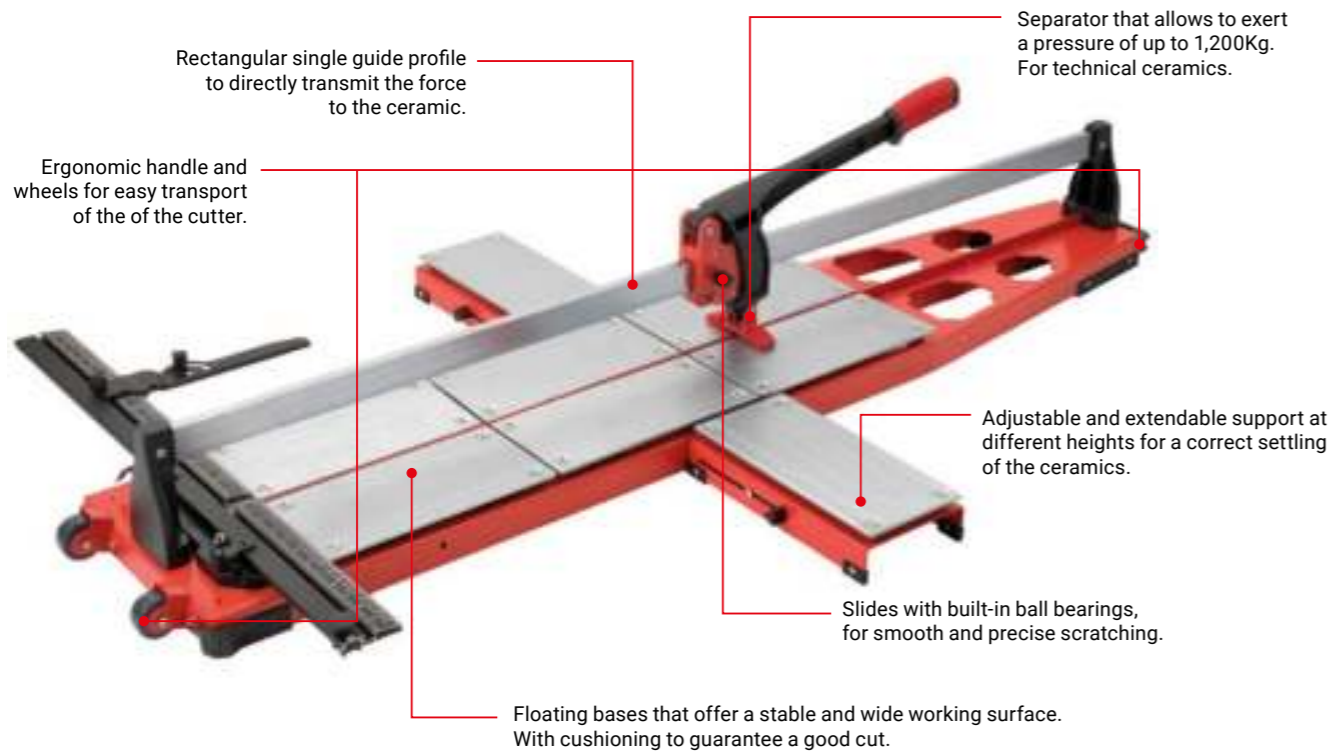

NEO TILE CUTTER

REF.	€	8 41 4299	g	A mm	B mm	C mm	X
NEO100	602,14	714876	1	30.000	1.280	300	300
NEO130	753,94	714883	1	34.500	1.530	300	300
NEO155	855,14	714890	1	38.000	1.780	300	300

Cutting capacity per tile:

REF.	g	A mm	B mm	C mm
NEO100	1.000 mm	18 mm		
NEO130	1.300 mm	18 mm		
NEO155	1.550 mm	18 mm		

With 22 mm roller and carrying bag.



LEAN BAG

REF.	€	8 41 4299	g	A mm	B mm	C mm	X
CASENEO100	319,18	016567	1	4.500	1.320	360	300
CASENEO130	342,59	016581	1	5.500	1.570	360	300
CASENEO155	366,00	016611	1	7.000	1.820	360	300

LEAN TILE CUTTER

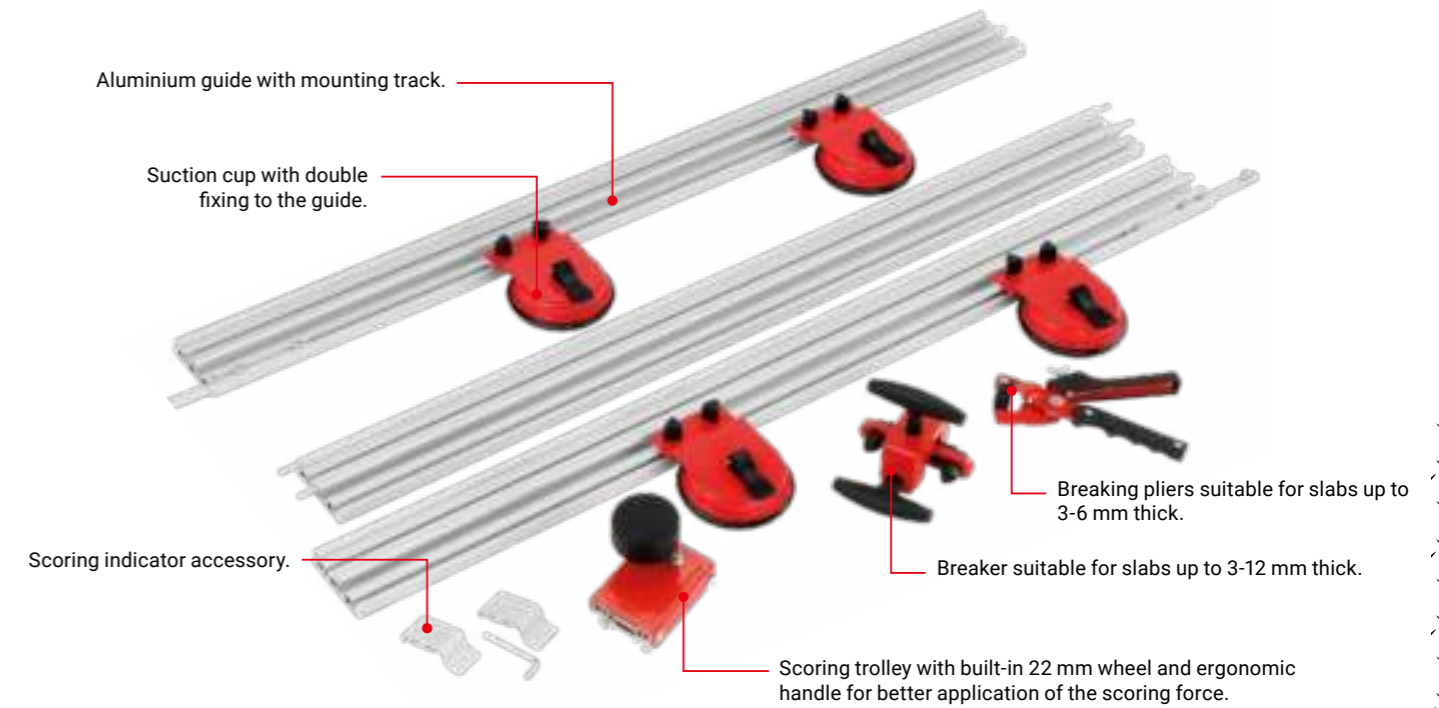

TILE CUTTER LEAN

REF.	€	8 41 4299	g	A mm	B mm	C mm	X
LEAN320	381,21	700275	1	9.500	1.220	160	160

Cutting capacity per tile:

REF.	g	A mm	B mm	C mm
LEAN320	3.220 mm	12 mm		

As of March, the accessories for the handling and placement of large-format tiles will be available: work table, conveyor and trolley. LEANWB, LEANCART and LEANLIFT.

BAG FOR LEAN320 CUTTER

REF.	€	8 41 4299	g	A mm	B mm	C mm	X
BAGLEAN	39,04	700312	1	680	1.200	220	160



NEW

► PLIERS PLIERLEANF

REF.	€	8 41 4299	g	A mm	B mm	C mm
PLIERLEANF	19,95	051650	6	330	260	75 50



NEW

► CONVEYOR LEAN

REF.	€	8 41 4299	g	A mm	B mm	C mm
LEANLIFT	1.669,75	019711	1	37.000	2.000	550 200



NEW

► WORKING TABLE FOR LEANWB

REF.	€	8 41 4299	g	A mm	B mm	C mm
LEANWB	637,51	019728	1	29.000	1.850	290 200



NEW

► TROLLEY LEAN

REF.	€	8 41 4299	g	A mm	B mm	C mm
LEANCART	627,77	020496	1	26.000	1.560	330 185

TECH TILE CUTTER

Sliders:
Maximum scoring smoothness, precision and durability thanks to double self-lubricating bushings.

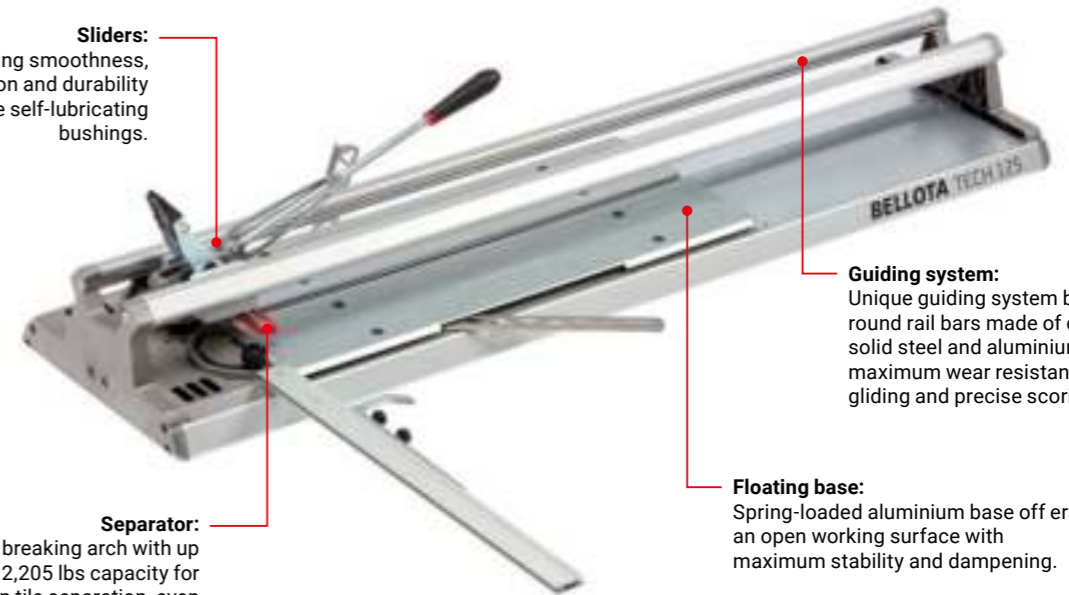

Guiding system:
Unique guiding system built with round rail bars made of chromeplated solid steel and aluminium stands for maximum wear resistance, smooth gliding and precise scoring.

Floating base:
Spring-loaded aluminium base offers an open working surface with maximum stability and dampening.

Separator:
Heavy-duty breaking arch with up to 1.000 kg / 2,205 lbs capacity for easy and clean tile separation, even high-density porcelain.



► TILE CUTTER TECH 75

REF.	€	8 41 4299	g	A mm	B mm	C mm
TECH 100	763,62	634259	1	17.730	1.220	360 170 X
TECH 125	945,46	622065	1	20.240	1.470	360 170 X

► TROLLEY TECH

REF.	€	8 41 4299	g	A mm	B mm	C mm
TECH100CASE	273,93	641202	1	6.060	1.355	390 220
TECH125CASE	322,01	641226	1	7.010	1.600	410 220

Cutting capacity per tile:

REF.	g	A mm	B mm	C mm
TECH100	1.000 mm	700 x 700 mm	20 mm	
TECH125	1.250 mm	880 x 880 mm	20 mm	

TECH75 includes XL 8 mm scoring wheel. TECH100 includes XL 10 mm scoring wheel. TECH125 includes XL 10/XL 18 mm scorings wheels.

PRO TILE CUTTER

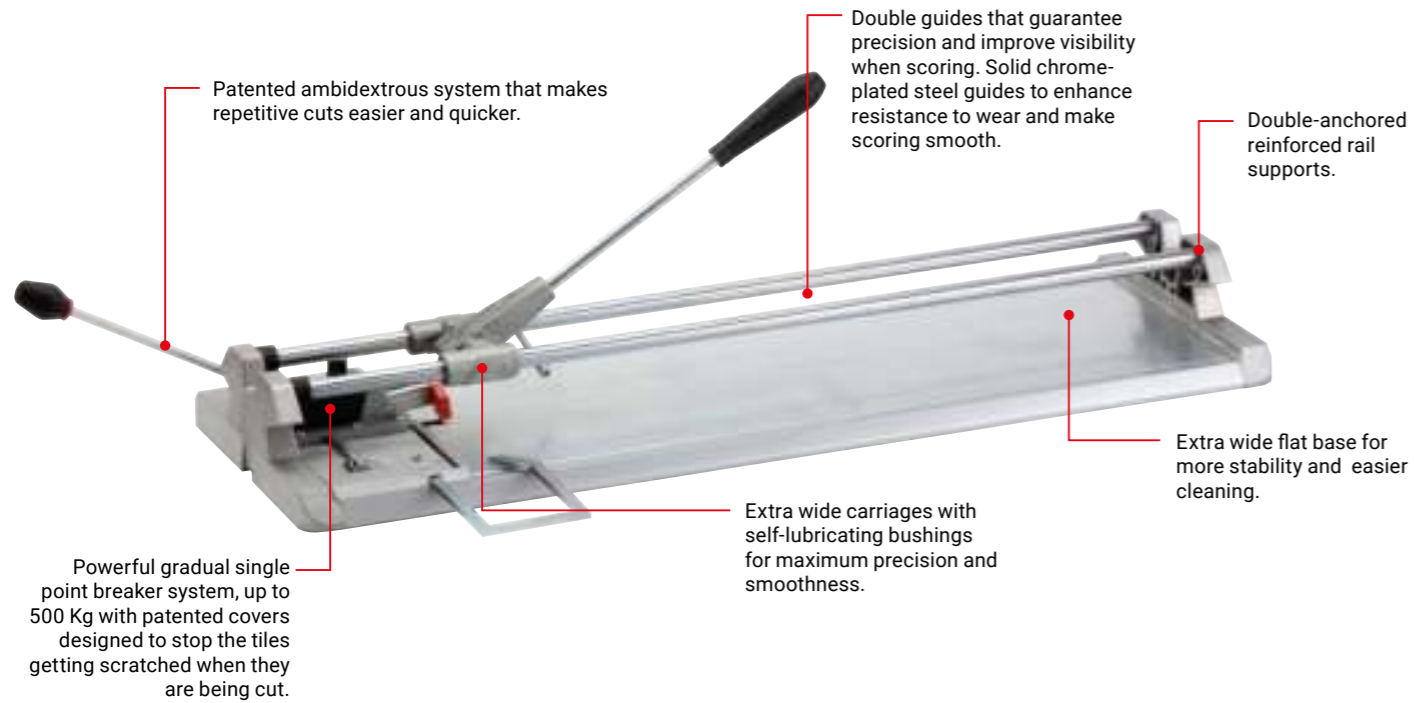

TILE CUTTER PRO 72

REF.	€	PROFUNDITÀ	g	A mm	B mm	C mm	
PRO 72	429,23	622041	1	11.650	905	327	100 X

Includes 6 mm and 10 mm Scoring Wheels.

Cutting capacity per tile:

REF.			
PRO72	72 cm	50 x 50 cm	15 mm

CASE PRO

REF.	€	PROFUNDITÀ	g	A mm	B mm	C mm	
PROPCASE	132,44	636215	1	4.420	127	955	460

FIT TILE CUTTER



TILE CUTTER FIT

REF.	€	PROFUNDITÀ	g	A mm	B mm	C mm	
FIT80	243,22	686258	1	9.000	1.040	250	120 0
FIT100	304,33	686272	1	11.000	1.240	250	120 0
FIT120	379,50	716917	1	12.520	1.440	250	120 0

Cutting capacity per tile:

REF.			
FIT80	850 mm	600 x 600 mm	15 mm
FIT100	1.050 mm	740 x 740 mm	15 mm
FIT120	1.250 mm	850 x 850 mm	15 mm

It comes with an 8 mm XL scoring wheel and a ruler stop-set square to make scoring easier.

FIT CERAMIC CUTTER WITH BAG

REF.	€	PROFUNDITÀ	g	A mm	B mm	C mm	
FIT80B	265,38	699043	1	9.665	1.040	250	120 X
FIT100B	327,11	699067	1	11.725	1.240	250	120 X
FIT120B	399,74	716924	1	13.320	1.440	250	120 X

Cutting capacity per tile:

REF.			
FIT80B	850 mm	600 x 600 mm	15 mm
FIT100B	1.050 mm	740 x 740 mm	15 mm
FIT120B	1.250 mm	850 x 850 mm	15 mm

It comes with an 8 mm XL scoring wheel and a ruler stop-set square to make scoring easier.



FIT CUTTER BAG

REF.	€	PROFUNDITÀ	g	A mm	B mm	C mm	
BAGFIT80	24,10	699081	10	665	500	300	50
BAGFIT100	36,19	699111	10	725	500	300	70
BAGFIT120	40,75	716894	10	800	500	300	70

POP TILE CUTTER

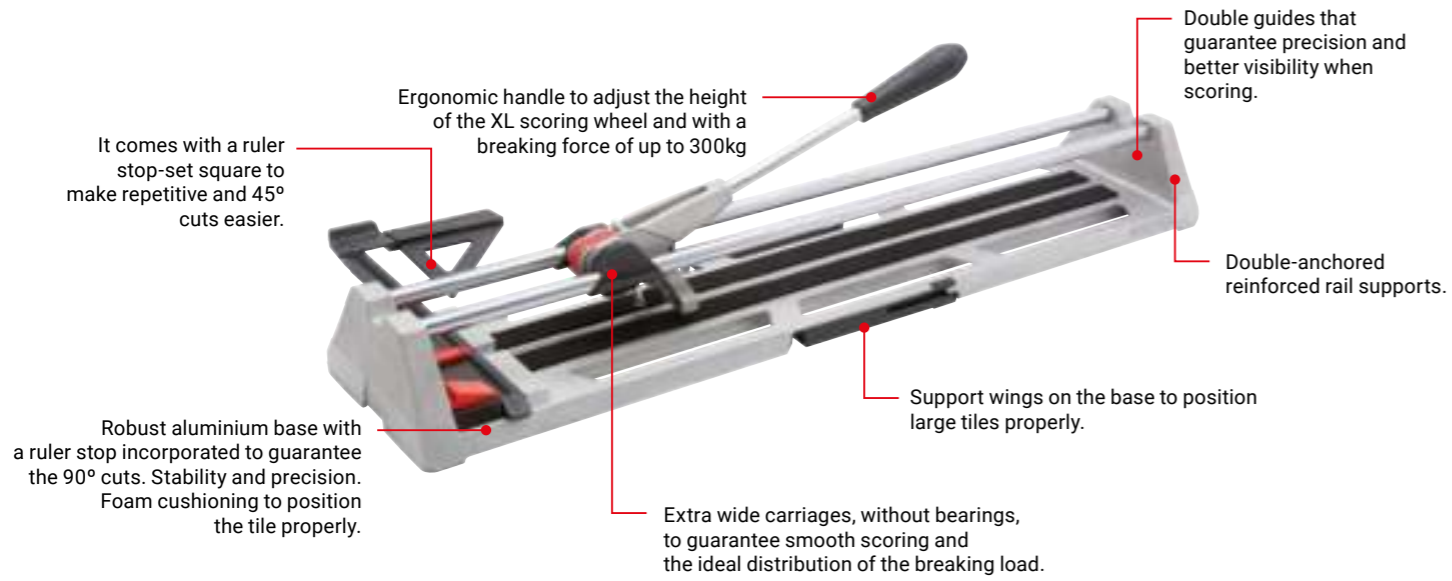

► TILE CUTTER POP

REF.	€	8 41 4299	g	A mm	B mm	C mm	
POP 50-B	83,69	621969	1	4.180	695	175	85 X
POP 50-C	96,03	621976	1	4.160	695	175	95 X
POP 60-B	110,80	622355	1	4.620	795	175	95 X
POP 60-C	125,58	621990	1	4.620	795	175	95 X

REF.			
POP50-B	530 mm	380 x 380 mm	12 mm
POP50-C	530 mm	380 x 380 mm	12 mm
POP60-B	630 mm	450 x 450 mm	12 mm
POP60-C	630 mm	450 x 450 mm	12 mm

Polymer runners. Includes 6 mm scoring wheel.



► PLASTIC CASE POP POPCASE

REF.	€	8 41 4299	g	A mm	B mm	C mm	
POP60PCASE	53,64	636031	1	1.970	122	835	249

PASS TILE CUTTER

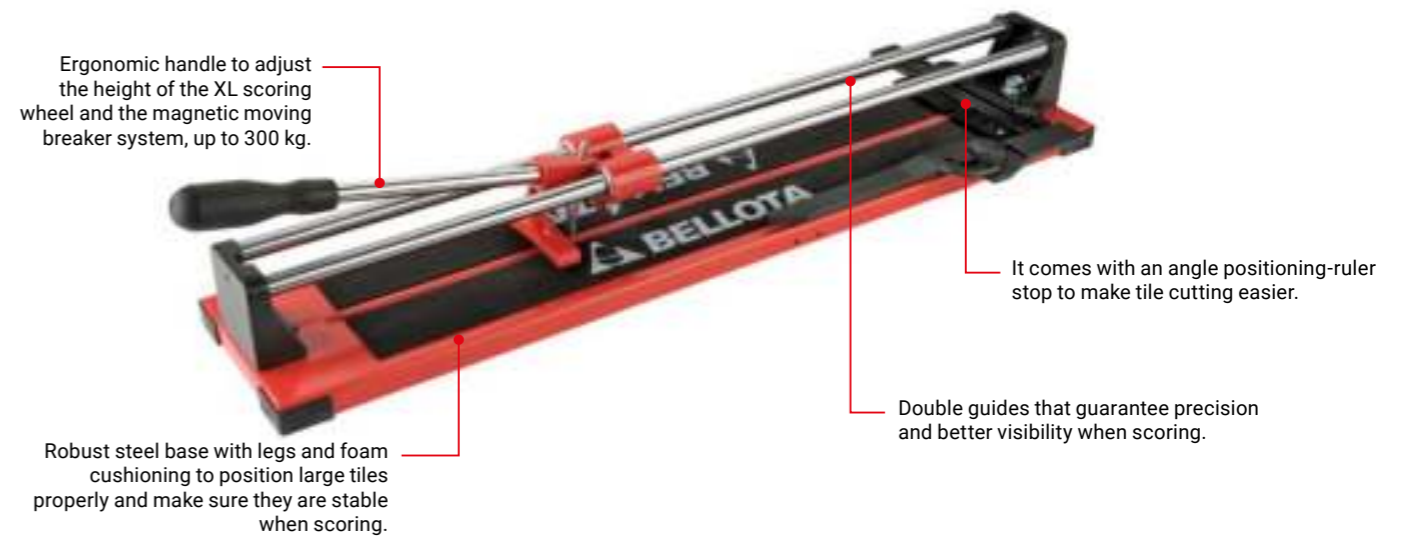

► TILE CUTTER PASS 60

REF.	€	8 41 4299	g	A mm	B mm	C mm	
PASS 60	97,02	688801	1	7.500	800	170	110 0

REF.			
PASS60	610 mm	420 x 420 mm	12 mm

Aluminium runners. Includes 6 mm scoring wheel and cutting guide set. Includes hard case for POP 50-R-C and POP 60-R-C.

* POP50-R-B/ POP50-R-C UNTIL END OF STOCK.

SCORING WHEELS

Accurate scoring. High density, sharp tungsten carbide roller guide for a longer service life

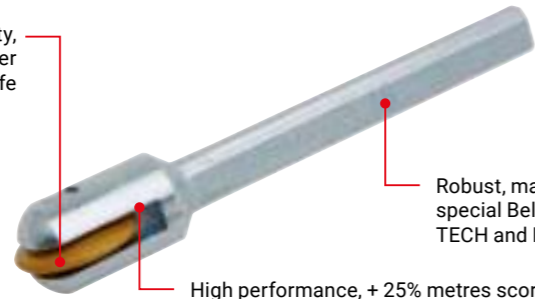

Robust, made out of one piece in special Bellota steel. XL version for TECH and FIT.

High performance, + 25% metres scoring in the standard version and +45% metres scoring in the Titanium version.



SCORING WHEEL 6

REF.	€	8 41 4299	g	A mm	B mm	C mm	
RODEL6	9,59	659276	10	30	5	6	83

For ceramic coatings. For POP and PRO tile cutters.



SCORING WHEEL 8

REF.	€	8 41 4299	g	A mm	B mm	C mm	
RODEL8	10,95	659290	10	30	7	6	83,5

For porcelain and ceramic stoneware. For POP and PRO tile cutters.



SCORING WHEEL 10

REF.	€	8 41 4299	g	A mm	B mm	C mm	
RODEL10	12,33	659320	10	30	9	9	84

For stoneware and porcelain stoneware. For POP and PRO tile cutters.



SCORING WHEEL 18

REF.	€	8 41 4299	g	A mm	B mm	C mm	
RODEL18	24,14	659504	10	40	17	10	84

For rustic paving and cladding or paving stones difficult to cut. For POP and PRO tile cutters.



TITANIUM SCORING WHEEL 8T

REF.	€	8 41 4299	g	A mm	B mm	C mm	
RODEL8T	14,15	659405	10	30	6	5	83,5

For porcelain and ceramic stoneware. Last up to 20% longer. For POP and PRO tile cutters.



TITANIUM SCORING WHEEL 10T

REF.	€	8 41 4299	g	A mm	B mm	C mm	
RODEL10T	15,57	659467	10	30	10	9	84

For stone[are] and porcelain stoneware. Last up to 20% longer. For POP and PRO tile cutters.



TITANIUM SCORING WHEEL 18T

REF.	€	8 41 4299	g	A mm	B mm	C mm	
RODEL18T	26,98	659610	10	40	17	10	84

For rustic paving and cladding or paving stones difficult to cut. Last up to 20% longer. For PASS, POP and PRO tile cutters



SCORING WHEEL XL 8

REF.	€	8 41 4299	g	A mm	B mm	C mm	
RODELXL8	14,85	659597	10	40	7	6	100

For porcelain and ceramic stoneware. For TECH and FIT tile cutters.



SCORING WHEEL XL 10

REF.	€	8 41 4299	g	A mm	B mm	C mm	
RODELXL10	16,29	659696	10	40	9	8	100

For stoneware and porcelain stoneware. For TECH and FIT tile cutters.



TITANIUM SCORING WHEEL XL 8T

REF.	€	8 41 4299	g	A mm	B mm	C mm	
RODELXL8T	17,79	659658	10	40	7	6	100

For stoneware and porcelain stoneware. Last up to 20% longer. For TECH and FIT tile cutters.



TITANIUM SCORING WHEEL XL 18T

REF.	€	8 41 4299	g	A mm	B mm	C mm	
RODELXL18T	30,63	659757	10	50	18	10	101

For rustic paving and cladding or paving stones difficult to cut. Last up to 20% longer. For TECH and FIT tile cutters.



ROLLER 22MM

REF.	€	8 41 4299	g	A mm	B mm	C mm
EVORUL22	9,66	691597	1	48	22	4



SCORING WHEEL XL 18

REF.	€	8 41 4299	g	A mm	B mm	C mm	
RODELXL18	27,76	659375	10	50	17	10	100

For rustic paving and cladding or paving stones difficult to cut. For TECH and FIT tile cutters.



TITANIUM SCORING WHEEL XL 10T

REF.	€	8 41 4299	g	A mm	B mm	C mm	
RODELXL10T	19,21	659726	10	40	10	8	100

For stoneware and porcelain stoneware. Last up to 20% longer. For TECH and FIT tile cutters.



ROLLER 22MM

REF.	€	8 41 4299	g	A mm	B mm	C mm	
LEANRUL22	10,85	700329	1	48	150	40	5

For stoneware and porcelain stoneware. For PASS and FIT120 tile cutters.



SCORING WHEEL XL 6

REF.	€	8 41 4299	g	A mm	B mm	C mm	
RODXL6	13,95	039047	10	40	7	6	100

For NEO



SCORING WHEEL XL 8

REF.	€	8 41 4299	g	A mm	B mm	C mm	
RODXL8	14,85	021035	10	40	7	6	100

For porcelain and ceramic stoneware. For PASS and FIT120 tile cutters.



SCORING WHEEL XL 10

REF.	€	8 41 4299	g	A mm	B mm	C mm	
RODXL10	16,29	021134	10	40	9	8	100

For stoneware and porcelain stoneware. For PASS and FIT120 tile cutters.



SCORING WHEEL XL 18

REF.	€	8 41 4299	g	A mm	B mm	C mm	
RODXL18	27,76	021257	10	50	17	10	100

For rustic paving and cladding or paving stones difficult to cut. For PASS and FIT120 tile cutters.

SPARE PARTS FOR TILE CUTTERS

NEO TILE CUTTER



► PARTS FOR NEO TILE CUTTER

REF.	€	PROFORMA 8 41 4299	QTY	Kg	A mm	B mm	C mm	REF.
NEOBASEFLO	27,95	715521	1	0,353	300	140	10	NEO
NEOSUPPORTS	39,22	715507	1	1,228	310	190	65	NEO
NEOSLIDER	98,05	715583	1	0,982	450	70	190	NEO
NEOPITCHER	3,95	715569	1	0,066	113	24	50	NEO
NEORULER	27,54	715606	1	0,657	800	460	40	NEO
NEOHANDLE	9,95	715484	1	0,075	153	52	24	NEO
NEOWHEEL	11,68	715460	1	0,3	140	60	55	NEO

LEAN TILE CUTTER



► PARTS FOR LEAN TILE CUTTER

REF.	€	PROFORMA 8 41 4299	QTY	Kg	A mm	B mm	C mm	REF.
BREAKLEAN	34,98	700299	1	0,63	110	125	135	LEAN
GUIDELEAN	74,95	700282	1	1,58	20	90	1.118	LEAN
PLIERLEAN	10,36	700442	1	0,355	290	170	50	LEAN
SCRATLEAN	131,31	427738	1	0,53	100	83	90	LEAN
SUCLEAN	17,47	627985	1	0,57	50	120	145	LEAN

TECH TILE CUTTER



► PARTS FOR TECH TILE CUTTER

REF.	€	PROFORMA 8 41 4299	QTY	Kg	A mm	B mm	C mm	REF.
TECH BREAKERHAND	13,04	646665	1	0,071	100	50	35	TECH
TECHCLIPS	6,13	646702	1	0,065	140	80	40	TECH
TECHHANDLE	12,74	646740	1	0,42	460	35	35	TECH
TECHPADS	9,81	645743	1	0,016	110	60	30	TECH
TECHRULE	44,67	646788	1	0,68	900	130	25	TECH
TECHSCREWS	5,93	646825	1	0,52	50	70	70	TECH
TECHSLIDERS	203,69	645729	1	0,365	130	90	55	TECH
TECHSUPPORTS	15,40	646863	1	0,1	320	20	40	TECH

PRO TILE CUTTER



► PARTS FOR PRO TILE CUTTER

REF.	€	PROFORMA 8 41 4299	QTY	Kg	A mm	B mm	C mm	REF.
POPHANDLE	9,66	636093	20	0,33	345	32	32	PRO55/PRO72
PROSNAPHANDLE	9,66	636277	20	0,27	275	35	35	PRO55/PRO72
PROGUIDESQU	14,66	636314	30	0,3	385	97	6	PRO55/PRO72
PROGUIDESCR	6,47	636352	20	0,03	30	20	20	PRO55/PRO72
PROJAWCOVERS	3,67	636390	20	0,02	25	28	7	PRO55/PRO72
PROBROKMECH	162,15	636437	1	1,15	260	150	80	PRO55/PRO72

FIT TILE CUTTER



► PARTS FOR FIT TILE CUTTER

REF.	€	PROFORMA 8 41 4299	QTY	Kg	A mm	B mm	C mm	REF.
FITHANDLE	8,85	689365	1	0,485	375	30	30	FIT
FITPITCHER	3,40	689440	1	0,048	130	15	40	FIT
FITRKIT	8,58	691528	1	0,166	400	150	15	FIT
FITSUPPORTS	7,54	689372	1	0,48	340	100	35	FIT
FITFOAM	15,28	707045	1	0,06	1060	80	20	FIT

POP TILE CUTTER



► PARTS FOR POP TILE CUTTER

REF.	€	PROFORMA 8 41 4299	QTY	Kg	A mm	B mm	C mm	REF.
POPHANDLE	9,66	636093	1	0,33	345	32	32	POP
POPPITCHER	7,08	636130	1	0,05	70	15	50	POP
POPRKIT	10,00	636178	1	0,3	320	160	40	POP

PASS TILE CUTTER



► PARTS FOR PASS TILE CUTTER

REF.	€	PROFORMA 8 41 4299	QTY	Kg	A mm	B mm	C mm	REF.
PASSHANDLE	7,54	691559	1	0,435	325	30	30	PASS
PASSPITCHER	7,54	691535	1	0,05	90	20	45	PASS
PASSFOAM	6,53	707069	1	0,3	600	60	6	PASS
PASSRKIT	5,99	691542	1	0,24	280	130	30	PASS

LEVELLING SYSTEMS

HOW MANY CROSSHEADS DO YOU NEED?

FOR STANDARD CROSSHEADS

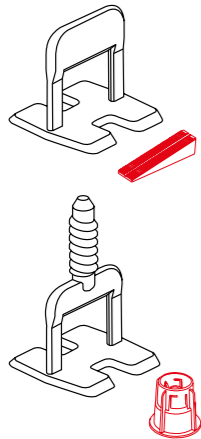

A	10	15	20	25	30	35	40	45	50	55	60	65	70	80	90	100	110	120	B	
10	200																			
15	133	89																		
20	100	67	50																	
25	80	53	40	32																
30	100	44	40	33	33															
35	100	67	50	40	29	28														
40	100	67	50	40	33	29	25													
45	89	59	44	36	30	25	22	20												
50	80	53	40	32	27	23	20	18	16											
55	73	48	36	29	24	21	18	16	15	13										
60	75	50	37	30	22	21	17	15	15	14	11									
65	69	46	35	28	23	20	17	15	14	13	12	11								
70	71	48	36	29	24	20	18	16	14	13	12	11	10							
80	69	46	34	28	23	20	16	14	14	12	10	10	10	9						
90	61	41	31	24	19	17	15	14	12	11	10	9	9	8	7					
100	60	40	30	24	20	17	15	13	12	11	10	9	9	9	8	8				
110	59	39	30	24	20	17	15	13	12	11	10	9	8	7	7	6				
120	54	36	27	22	18	15	14	12	10	10	8	8	8	7	7	6	6			

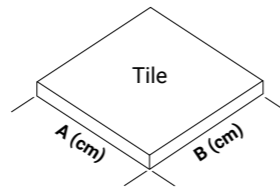

FOR CROSS-SHAPED CROSSHEADS

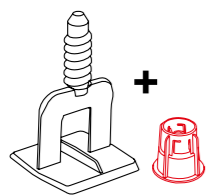

A	30	40	45	50	60	80	90	100	120	B
120					5	4	4	3	4	3
100					6	5	5	5		
90	10						4			
80		8	7		5	5				
60	11	9	8		6					
50				8						
45			10							
40		13								

HOW TO BREAK?

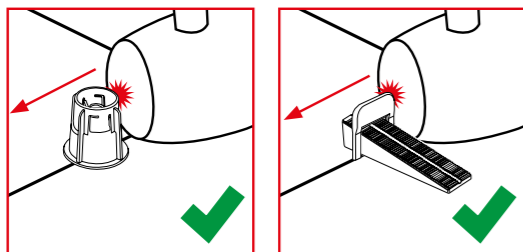

HOW NOT TO BREAK?

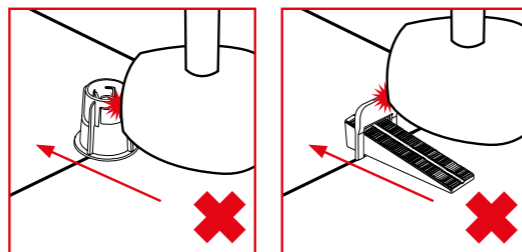

LEVELLING SYSTEMS

PUSH & LEVEL SYSTEM



PUSH SYSTEM LEVELLING CROSSHEAD

REF.	€	g	A mm	B mm	C mm	L mm	Uni. Box	Uni. Pack
LSS005	24,02	672954	1	880	70	260	450	0,5 200 2.000
LSS010	24,02	672992	1	880	70	260	450	1 200 2.000
LSS020	24,02	673036	1	880	70	260	450	2 200 2.000
LSS030	24,02	673074	1	880	70	260	450	3 200 2.000
LSS015	24,02	707908	1	880	70	260	450	1,5 200 2.000



NEW

1MM PUSH SYSTEM LEVELLING CROSSHEAD FOR 20 MM CERAMIC TILES

REF.	€	g	A mm	B mm	C mm	L mm	Uni. Box	Uni. Pack
LSS010S	28,34	673111	1	892	70	260	450	1 200 2.000
LSS040S	28,34	706239	1	932	70	260	450	4 1 10
LSS050S	28,34	706253	1	975	70	260	450	5 1 10
LSS030S	28,34	706550	1	963	70	260	450	3 1 10
LSS020S	28,34	673630	1	927	80	460	260	2 200 2.000

For four tiles of up to 20 mm thick.



PUSH LEVELLING CROSSHEAD IN CROSS SHAPE

REF.	€	g	A mm	B mm	C mm	L mm	Uni. Box	Uni. Pack
LSS010CROSS	24,02	673142	1	970	70	260	450	1 200 2.000
LSS020CROSS	24,02	650877	1	970	70	260	450	2 200 2.000
LSS030CROSS	24,02	682090	1	970	70	260	450	3 200 2.000



PUSH SYSTEM LEVELLING CROSSHEAD IN T-SHAPE

REF.	€	g	A mm	B mm	C mm	L mm	Uni. Box	Uni. Pack
LSS010T	24,02	673173	1	880	70	260	450	1 200 2.000
LSS020T	24,02	682175	1	880	70	260	450	2 200 2.000
LSS030T	24,02	682250	1	880	70	260	450	3 200 2.000

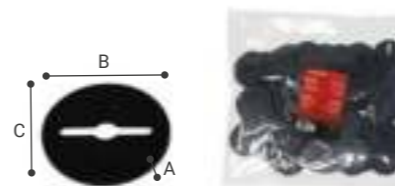

BASE

REF.	€	g	A mm	B mm	C mm	Uni. Box	Uni. Pack
LSPLATE	10,80	673586	1	540	30	260	310 100 2.500

For thin floor tiles of up to 3 mm.



LEVELLING THREAD

REF.	€	g	A mm	B mm	C mm	Uni. Box	Uni. Pack
LSSCREW	67,24	673210	1	1.130	100	260	530 100 500



PUSH & LEVEL KIT

REF.	€	g	A mm	B mm	C mm	L mm	Uni. Box	Uni. Pack
LSSKIT010	49,53	672916	1	1.950	280	280	200 1 100 100	
LSSKIT020	49,53	672930	1	1.930	280	280	200 2 100 100	
LSSKIT030	49,53	686982	1	1.940	280	280	200 3 100 100	

100 chocks and 50 push

WEDGE LEVELLING SYSTEM



► WEDGE

REF.	€	8 41 4299	g	A mm	B mm	C mm	
LSWEDGE	24,67	673517	1	1.860	70	260	500



► METAL PLIERS

REF.	€	8 41 4299	g	A mm	B mm	C mm	Uni. Box	Uni. Pack
LSPLIER	23,63	673296	1	360	50	170	290	1 10



► WEDGE LEVELLING CROSSHEAD

REF.	€	8 41 4299	g	A mm	B mm	C mm	L mm	Uni. Box	Uni. Pack
LSW005	23,63	673319	1	890	70	260	450	0,5	250 2.500
LSW010	23,63	673357	1	950	70	260	450	1	250 2.500
LSW015	23,63	673371	1	990	70	260	450	1,5	250 2.500
LSW020	23,63	673418	1	980	70	260	450	2	250 2.500
LSW0202000	188,89	675436	1	7.900	470	370	365	2	2000 2.000
LSW030	24,67	673449	1	1.040	70	260	450	3	250 2.500
LSW0302000	197,18	675474	1	8.300	470	370	365	3	2000 2.000
LSW0152000	188,89	700268	1	7.800	470	370	365	1,5	2000 2.000



► 1MM WEDGE LEVELLING CROSSHEAD

REF.	€	8 41 4299	g	A mm	B mm	C mm	L mm	Uni. Box	Uni. Pack
LSW010S	26,92	673470	1	1.153	70	260	500	1	250 2.500
LSW030S	26,92	453584	1	1.175	70	260	500	3	
LSW040S	26,92	453690	1	1.234	70	260	500	4	
LSW050S	26,92	453799	1	1.433	70	260	500	5	
LSW020S	26,92	673616	1	1.162	80	460	260	2	250 2.500

For four tiles of up to 20 mm thick.



► WEDGE LEVELLING KIT

REF.	€	8 41 4299	g	A mm	B mm	C mm	L mm	Uni. Box	Uni. Pack
LSWKIT010	48,38	673258	1	2.020	280	280	200	1	100 100
LSWKIT020	48,38	673272	1	2.030	280	280	200	2	100 100
LSWKIT030	48,38	686999	1	2.160	280	280	200	3	100 100

100 chocks 100 wedges and 1 pliers.

TILE SPACERS

- Made with high quality pure plastic, no impurities. Consistently high quality, burr-free.
- Squared perfectly at 90°: maximum precision, which guarantees an excellent finish in the joints.
- Reinforced structure: maximum durability and strength.
- Tiles keep in place both vertically and horizontally. They do not move.

Uses:

- To obtain the perfect joints when tiling, both in terms of wall tiles and floor tiles.

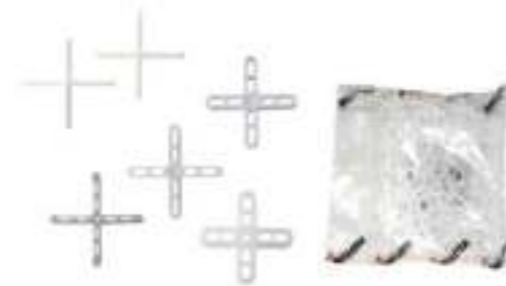

► 1MM TILE SPACER

REF.	€	8 41 4299	g	A mm	B mm	C mm	L mm	Uni. Box	Uni. Pack
SPC010	1,93	672466	1	70	180	190	30	1 200	10.000
SPC020	1,93	672510	1	100	230	190	30	2 200	10.000
SPC030	2,71	672558	1	150	230	190	30	3 200	10.000
SPC050	2,95	672596	1	240	280	190	30	5 200	10.000
SPC070	3,29	672633	1	340	330	190	30	7 200	10.000
SPC100	4,77	672671	1	50	360	170	40	10 200	10.000
SPC015	1,93	686319	1	850	200	190	30	1,5 200	20.000
SPC0101000	9,27	695434	1	40	30	180	190	1 1000	20.000
SPC0151000	9,27	695458	1	70	20	230	190	1,5 1000	20.000
SPC0201000	8,88	695472	1	70	20	230	190	2 1000	20.000
SPC030500	5,21	700893	1	120	30	190	230	3 500	20.000



► 1MM TILE SPACER T

REF.	€	8 41 4299	g	A mm	B mm	C mm	L mm	Uni. Box	Uni. Pack
SPC010T	2,00	672718	1	50	180	190	20	1 200	10.000
SPC020T	2,00	672756	1	70	180	190	20	2 200	10.000
SPC030T	2,84	672794	1	90	180	190	20	3 200	10.000

WEDGES

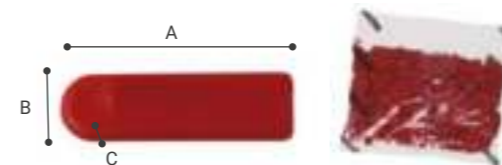

► 6MM WEDGE

REF.	€	8 41 4299	g	A mm	B mm	C mm	L mm	Uni. Box	Uni. Pack
SPCWEDGE	2,59	672879	1	140	180	190	30	5 200	10.000

ACCESSORIES FOR TILING

TILING BUCKET

- Very strong plastic bucket. Maximum capacity of 20 litres.
- 3 wringer rollers and a grate at the bottom: excellent wringing capacity.
- Sloped base so that all the sediment from cleaning settles at the bottom.
- Easy to use and move around. Wheels and handles to move around.

Uses:

- Tile cleaning jobs.

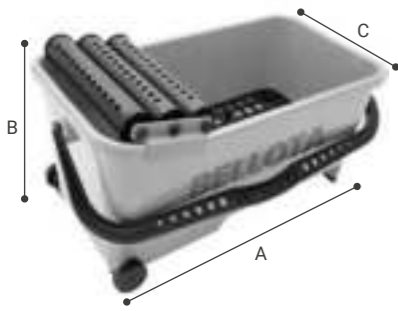

► PROFESSIONAL TILING BUCKET 5800

REF.	€	8 41 4299	g	A mm	B mm	C mm
5800-3	45,90	631081	1	1.820	515	265
5800-3 BP	41,32	631104	8	1.830	520	270

BP comes in a Box- Pallet.



► PROFESSIONAL TILING BUCKET 5800KIT

REF.	€	8 41 4299	g	A mm	B mm	C mm
5800-3KIT	73,45	623215	1	2.400	560	290

Include: Ref 5800, Ref 5898B, Ref 5888 and Ref CS121875.



► WHEEL AND LEG KIT FOR TILED BUCKET

REF.	€	8 41 4299	g	A mm	B mm	C mm
58003RW	4,62	656039	1	40	100	50



► SET 3 ROLLERS FOR TILED BUCKET

REF.	€	8 41 4299	g	A mm	B mm	C mm
58003RROD	31,95	656046	6	310	270	140

SPONGES

- Made with top quality materials.
- Maximum water absorption capacity.
- Great for cleaning and removing dirt.
- Very strong and long-lasting.
- EXTRA ABSORBENT range with longitudinal sections for greater absorption and dirt removal.

Uses:

- Cleaning jobs. Professional use.

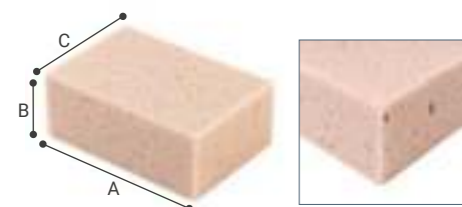

► SIMPLE SPONGE CS12187S

REF.	€	8 41 4299	g	A mm	B mm	C mm
CS12187S	1,99	632095	25	30	180	70

Average absorption capacity and durability. Abrasive polyester layer for better surface cleaning.



► MIXED SPONGE CS12187MX

REF.	€	8 41 4299	g	A mm	B mm	C mm
CS12187MX	3,27	632132	25	40	180	70

Average absorption capacity and high durability.



► CLOUD SPONGE CSW12187

REF.	€	8 41 4299	g	A mm	B mm	C mm
CSW12187	3,39	632170	25	50	180	70

High absorption capacity and durability. Stays wet longer, makes work easier.



► EXTRA ABSORPTION CLOUD SPONGE CSW12187E

REF.	€	8 41 4299	g	A mm	B mm	C mm
CSW12187E	4,09	632194	25	50	120	180

High absorption capacity and durability. Stays wet longer, makes work easier. With longitudinal sections for greater absorptions and removal of dirt. * AVAILABLE UNTIL END OF STOCK.



► CELLULOSE SPONGE CS10174C

REF.	€	8 41 4299	g	A mm	B mm	C mm
CS10174C	7,08	639469	6	50	175	95

Very high absorption capacity and durability.

SUCTION CUPS

- Plastic suction cups: 40 kg holding capacity. (Simple) and 70kg (double), with white rubber to avoid marking the parts. For smooth surface finishes.
- Aluminium suction cups: 40 kg holding capacity. (simple), 70kg. (Double) 100kg. (triple), with white rubber to avoid marking the parts. For smooth surface finishes.
- Suction cup with vacuum pump: 120 kg holding capacity, with Flack grooved rubber for rough surface finishes, with vacuum indicator, manual release valve and carrying case for safe transport. For handling heavy materials or large format tiles regardless of surface finish.

Uses:

- Multifunctional. For handling heavy materials, medium or large ceramic tiles and glass panes...

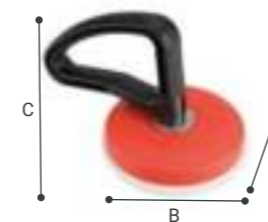

► SINGLE PLASTIC SUCTION CUP SUCP40SP

REF.	€	8 41 4299	g	A mm	B mm	C mm
SUCP40SP	13,82	704945	1	252	120	120
SUCP70SP	26,61	704969	1	470	320	115



► TRIPLE ALUMINIUM SUCTION CUP SUCA100SP

REF.	€	8 41 4299	g	A mm	B mm	C mm
SUCA40SP	17,01	699425	1	420	120	120
SUCA70SP	35,14	699449	1	791	320	120
SUCA100SP	50,06	699463	1	1.126	320	225



► VACUUM PUMP SUCTION CUP SUCR100RBPN

REF.	€	8 41 4299	g	A mm	B mm	C mm
SUCR100RBPN	74,95	039856	1	1.510	235	110



► ADHESIVE FOAM 120MM SUCPAD

REF.	€	8 41 4299	g	A mm	B mm	C mm
SUCPAD	7,49	042740	1	31	120	120

WORK BENCH

- Sturdy and stable workbench with steel legs and structure. Stands up to a maximum of 450 kg.
- 940mm long by 480mm wide workbench, with tool tray, sorters, ruler and angle protractor for comfortable working.
- Easy transport and storage, with carrying handle and foldable design for minimum space requirements.

Uses:

- Multifunctional, for everything you need: Scaffold, trestle or workbench, adjustable in 3 heights (520mm, 660mm and 800mm).



► FOLDING WORKBENCH, ADJUSTABLE IN 3 HEIGHTS FWB01

REF.	€	8 41 4299	g	A mm	B mm	C mm	
FWB01	158,99	700466	1	12.000	105	480	940

It can be used as a workbench or scaffold at different heights.

TILING LEVELLER

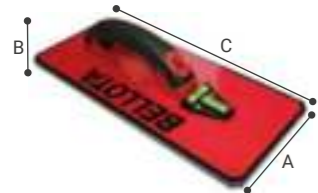

► RUBBER LEVELLER 8056

REF.	€	8 41 4299	g	A mm	B mm	C mm	
8056	26,95	051926	6	2.337	355	146	78,5

NEW

STENCIL



► MARKER FOR HOLES 1040MM

REF.	€	8 41 4299	g	A mm	B mm	C mm	
MAGUJEROS	19,95	051414	12	221	175	120	30

NEW

HOLE MARKER



► TEMPLATE FOR SHAPES 260MM

REF.	€	8 41 4299	g	A mm	B mm	C mm	
PFORMAS	19,95	049114	12	486	132	318	21

NEW

JOINT SCRAPER



► SCRAPER BLADES RJUNTASR

REF.	€	8 41 4299	g	A mm	B mm	C mm	
RJUNTASR	3,45	048872	20	14	50,5	1	19,5

NEW



► JOINT SCRAPER

REF.	€	8 41 4299	g	A mm	B mm	C mm	
RJUNTAS	6,95	048827	6	115	191	27	62

NEW

HACKSAWS, BLADES AND SAWS

HACKSAWS

- Hacksaws with optimal finishes for high sawing capacity and comfortable sawing.
 - Tension blade system included.
 - Quick change of the blade.
- Includes Blade, ref. 4604-12.24, with 24 teeth.
- Three different kind of steel:
 - Bimetal Flexible Blade HSS: Rapid M2 steel edge, for professional use.
 - Bimetal Flexible Blade HSS: Rapid M2 steel edge, for professional use.
 - Rigid Blade HSS: Rapid M2 steel edge. For professional use for Mechanics fork works.
 - Flexible Blade: Alloy steel, for soft steel, nonferrous metal and plastic.
- Ergonomic handle for higher comfort.

Uses:

- For cutting frames, steel, aluminium, stainless steel, PVC, etc. and various sawing jobs.

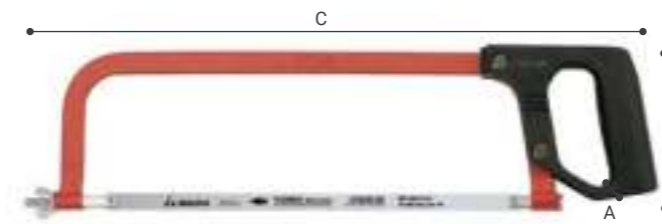

► HACKSAW 4621

REF.	€	8 41 4299	g	A mm	B mm	C mm	
4621-12	14,24	404869	12	520	23	126	469

5 mm solid plate. Professional.



► ALUMINIUM HACKSAW 4630

REF.	€	8 41 4299	g	A mm	B mm	C mm	
4630-12	25,29	404883	6	560	22	153	387

Aluminium. Strong and light.



► BIMETAL HSS BLADE 4601

REF.	€	8 41 4299	g	A mm	B mm	C mm	
4601-12.18	2,47	923445	100	20	1	13	311
4601-12.24	2,47	405026	100	20	1	12	311



► BIMETAL HSS BLADE 4601

REF.	€	8 41 4299	g	A mm	B mm	C mm	
4601-12.24 BS	6,69	206074	12	40	1	40	378



► RIGID HSS BLADE 4602

REF.	€	8 41 4299	g	A mm	B mm	C mm	
4602-12.18	2,36	923483	100	20	1	13	312
4602-12.24	2,29	406177	100	20	1	13	311



► RIGID HSS BLADE 4602

REF.	€	8 41 4299	g	A mm	B mm	C mm	
4602 12.24 BS	6,31	206166	12	40	1	40	378



► FLEXIBLE BLADE 4604

REF.	€	8 41 4299	g	A mm	B mm	C mm	
4604-12.18	1,15	923520	100	20	1	13	308
4604-12.24	1,12	405118	100	20	1	13	312



► FLEXIBLE BLADE 4604

REF.	€	8 41 4299	g	A mm	B mm	C mm	
4604-12.18	1,15	923520	100	20	1	13	308
4604-12.24	1,12	405118	100	20	1	13	312

SAW FOR CARPENTRY

- Made with special Bellota steel.
- Three edge toothing for easy cleaning and cutting.
- Double heat treatment for better performance: blade fully heat treated with double quenching on the teeth.
- Handle designed to transmit maximum strength along teeth.
- Two types of handles:
 - Varnished handles, light and pleasant touch wooden handles.
 - Bi-material ergonomic handles with SOFT TOUCH for comfort during work.

Uses:

- For wood cutting, particle boards and other materials.



▶ SAW 4551

REF.	€	8 41 4299	g	A mm	B mm	C mm	L mm
4551-14	27,80	300901	6	410	25	130	345
4551-16	29,72	301007	6	420	25	130	505
4551-19	34,10	360899	6	490	25	140	580
4551-22	37,84	301304	6	510	25	140	660



▶ BIMATERIAL HANDLE SAW 4555

REF.	€	8 41 4299	g	A mm	B mm	C mm	L mm
4555-14	23,50	313611	6	450	35	135	345
4555-16	24,82	313628	6	450	35	135	515
4555-19	28,52	447194	6	540	35	140	585
4555-22	32,13	313659	6	560	35	145	670



▶ BACKSAW 4561

REF.	€	8 41 4299	g	A mm	B mm	C mm	L mm
4561-12	36,36	302707	6	480	24,9	150	400
4561-14	38,88	302806	6	550	25	150	450

Rib on the upper section of the blade to guarantee rigidity while cutting.



▶ BIMATERIAL HANDLE BACKSAW 4565

REF.	€	8 41 4299	g	A mm	B mm	C mm	L mm
4565-12	32,43	313734	6	530	35	150	410
4565-14	34,97	313741	6	580	35	150	460

Rib on the upper section of the blade to guarantee rigidity while cutting.

WOODWORK SAW



▶ WOODWORK SAW 4568-S

REF.	€	8 41 4299	g	A mm	B mm	C mm	L mm
4568-S	16,38	623345	6	190	30	66	355



▶ WOODWORK SAW 4568-L

REF.	€	8 41 4299	g	A mm	B mm	C mm	L mm
4568-L	16,38	624328	6	220	49	71	375

Angled handle for a bevelled cut.

* AVAILABLE UNTIL END OF STOCK

KEYHOLE SAW



▶ KEYHOLE SAW 4572

REF.	€	8 41 4299	g	A mm	B mm	C mm	L mm
4572-10	19,59	303001	6	170	20	105	265
4572-12	19,95	303100	6	190	25	105	455

To use in difficult access areas.



▶ KEYHOLE SAW 4521

REF.	€	8 41 4299	g	A mm	B mm	C mm	L mm
4521	22,70	199093	6	138	27	55	310

Sharpened point. Blade thickness 1,8 mm.

DRYWALL SAW



▶ DRYWALL SAW 4520

REF.	€	8 41 4299	g	A mm	B mm	C mm	L mm
4520-15	31,28	561449	6	440	35	150	478

Pointed blade end to cut in ceiling-wall locations. 4520-20 AVAILABLE

UNTIL END OF STOCK.

WOOD CHISELS

WOOD CHISEL

- Chrome-Vanadium steel blades re-sharpenable along their entire length. Perfectly straightened and turned blades.
- Accurate blade heat treatment: maximum durability and wear resistance.
- Square key section preventing the blade from turning in the handle.
- Sleeved using a pneumatic press for correct blade-key joint.
- Varnished blades to prevent rust.
- Two types of handles:
 - Varnished handles, light and pleasant touch wooden handles.

Uses:

- For sizing, adjustments and finishing work on wood.

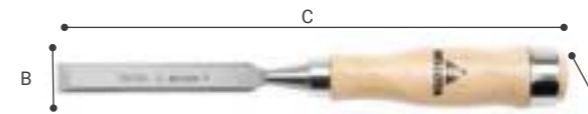

▶ WOOD CHISEL 4651

REF.	€	8 41 4299	g	A mm	B mm	C mm	L mm
4651-4	14,60	417234	6	120	28	32	262
4651-6	14,71	417272	6	120	28	32	262
4651-8	15,03	415032	6	130	28	32	264
4651-10	15,47	417357	6	140	28	32	266
4651-12	16,07	417449	6	490	28	32	268
4651-14	16,60	417487	6	150	28	32	270
4651-16	16,81	417524	6	160	28	32	272
4651-18	17,34	417562	6	160	28	32	274
4651-20	18,07	417609	6	180	28	32	276
4651-22	19,07	417647	6	180	28	32	278
4651-24	20,07	417685	6	180	28	32	280
4651-26	20,96	417722	6	180	28	32	282
4651-28	21,54	417760	6	200	28	32	284
4651-30	22,14	417807	6	210	28	32	286
4651-32	23,62	417845	6	210	28	32	288



▶ WOOD CHISEL KIT 8910

REF.	€	8 41 4299	g	A mm	B mm	C mm	L mm
8910	125,76	429879	4	302	43	335	232 6;10;16;20;26

Includes Ref: 4651-6, 4651-10, 4651-16, 4651-20, 4651-26.

CUTTING TOOLS

CUTTERS

- High-quality, toughened carbon steel knives: long life.
- Fast blade change, no need to open the cutter.
- Locking point using a wheel: ref. 51404 and 51406.
- Stainless steel guides for perfect sliding of the knife.
- Very ergonomic, comfortable and easy to use.

Uses:

- For various materials cutting.
- Especially recommended for laminated Plasterboard cutting.

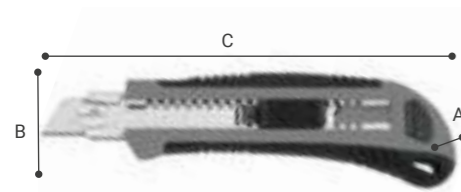

► BIMATERIAL CUTTER 51404

REF.	€	8 41 4299	g	A mm	B mm	C mm	L mm
51404-18	9,68	561487	12	160	25	172	18

Includes 5 blades.



► BLADE FOR BIMATERIAL CUTTER H51404

REF.	€	8 41 4299	g	A mm	B mm	C mm	L mm
H51404-18	4,42	561593	10	10	0,5	18	110

Blister with 10 blades.



► BIMATERIAL CUTTER 51405

REF.	€	8 41 4299	g	A mm	B mm	C mm	L mm
51405-25	10,61	561531	12	110	21	188	25

Includes 1 blade 25 mm.



► BLADE FOR BIMATERIAL CUTTER H51405

REF.	€	8 41 4299	g	A mm	B mm	C mm	L mm
H51405-25	5,86	561630	10	20	0,7	25	137

Blister with 10 blades.



► TITANIUM BLADE BIMATERIAL CUTTER 51406

REF.	€	8 41 4299	g	A mm	B mm	C mm	L mm
51406-18	16,59	561555	12	160	25	48	169

Includes 6 blades 18 mm. Last 8 times longer than other blades.



► TITANIUM BLADE FOR BIMATERIAL CUTTER H51406

REF.	€	8 41 4299	g	A mm	B mm	C mm	L mm
H51406-18	6,48	561654	10	10	0,5	18	110

Blister with 10 blades.



► METAL CUTTER 51407

REF.	€	8 41 4299	g	A mm	B mm	C mm	L mm
51407	16,81	561579	12	158	20	139	19

Includes 5 blades.



► BLADE FOR METAL CUTTER H51407

REF.	€	8 41 4299	g	A mm	B mm	C mm	L mm
H51407	4,25	562538	10	10	0,5	19	60

Blister with 5 blades.

SNIPS

- High-quality Chrome Molybdenum toughened blue steel snips. Long life.
- Forged blades, sharpened edges, for less cutting force for the user.
- 1.5 mm cutting capacity.
- Complies with US standards. ASMEB107.16.1998.

Uses:

- Cutting patterns and frames and other materials (aluminium, PVC)

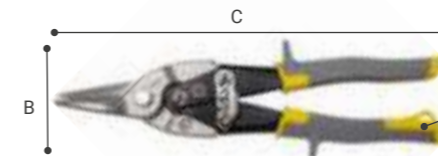

► STRAIGHT CUTS SNIPS 6006-S

REF.	€	8 41 4299	g	A mm	B mm	C mm	L mm
6006-S	17,45	561388	6	390	25	74	250



► BI-MATERIAL HANDLE TROWEL 6006R

REF.	€	8 41 4299	g	A mm	B mm	C mm	L mm
6006R	17,45	561401	6	390	25	74	250

NEW



► METAL SNIPS FOR LEFT HAND CUT

REF.	€	8 41 4299	g	A mm	B mm	C mm	L mm
6006L	17,45	561425	6	390	25	74	250

NEW

STUD CRIMPER

- Made with top quality materials: long life.
- High quality toughened alloy steel punch: high perforating capacity.
- Excellent mounting, solid and long lasting punch.

Uses:

- Ideal for joining metal stood to metal track.

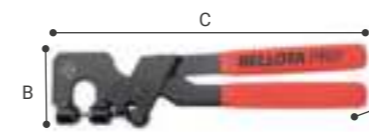

► STUD CRIMPER 6008

REF.	€	8 41 4299	g	A mm	B mm	C mm	L mm
6008	25,78	700916	1	860	25	75	310

RIVETER



► RIVETER 6170

REF.	€	8 41 4299	g	A mm	B mm	C mm	L mm
6170	23,63	340778	6	538	25	80	260

LASER LEVELING AND MEASURING

1
2
3

▶ **Self-leveling:**

On sloped surfaces up to 4° with visual or audible level alarm and pendulum lock. To guarantee your work.

▶ **Class II laser beam:**

With an accuracy of 0.3 mm/m and robust housing with anti-impact side stops and IP54 protection against dust and water splashes from all angles.

▶ **Complete kits:**

With 1/4" thread, magnetic holder and everything necessary for each user.

CHARACTERISTICS

USES

**NIV20R
NIV20V**



- ▶ It projects its light up to 20 metres away.
- ▶ It has a horizontal level plane and a vertical plane. Both with a 120° beam opening.
- ▶ With magnet, batteries and carrying case.

- ▶ To remove levels and 1 square. For any type of reform or installation.

NIV30V



- ▶ It projects its light up to 30 metres away and has 2 green plummet points. 50 metres range with receiver.
- ▶ It has a horizontal level plane with a 120° amplitude and a vertical plane with an amplitude of 180°. 2 intensities.
- ▶ It has a rotating magnet, clamp, reflective plate, glasses, batteries and a sturdy carrying case.

- ▶ To remove levels, 1 square and to obtain plumb lines. Especially designed for masons and tilers and for any type of renovation.

**NIV30360R
NIV30360V**



- ▶ It projects its light up to 30 metres away and up to 50 metres with receiver.
- ▶ It has a 360° horizontal level plane and two 360° vertical planes. 2 intensities.
- ▶ It has a rotating magnet, clamp, reflective plate, charged battery, charger and a sturdy carrying case.

- ▶ To remove levels and 2 squares.
- ▶ NIV30360R / NIV30360V: Especially designed for plasterers and masons and for any type of renovation.
- ▶ NIV30360VT: Specially designed for tilers to make the first row.

MED50R



- ▶ It has a rotating magnet, clamp, reflective plate, charged battery, charger and a sturdy carrying case.
- ▶ It offers multiple operations such as addition, subtraction, area, volume, Pythagoras and different units of measurement (mm, cm, Ft, inch...).
- ▶ Memory storage of 99 units. Including case, square, 6 mm and 10 mm scoring wheels.
- ▶ Textile case, strap and batteries included. Minimum autonomy of 8,000 uses.

- ▶ For measuring and calculating distances, areas and volumes and easy budgeting.
- ▶ For any type of reform.

WHAT DO YOU WANT TO DO?



	NIV20R	NIV20V	NIV30V	NIV30360R	NIV30360V	NIV30360VT
Colour	●	●	●	●	●	●
Reach	20	20	30 (Up to 50 m with receiver)	30 (Up to 50 m with receiver)	30 (Up to 50 m with receiver)	30 (Up to 50 m with receiver)
Battery / Batteries	Batteries	Batteries	Batteries	Battery	Battery	Battery
Beam opening	120x120	120x120	120x180 and 2 plumb lines	360 x 3	360 x 3	360 x 3 (Low plain)



DIGITAL LEVEL

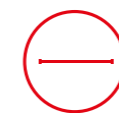

DISTANCE



AREA



VOLUME

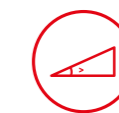

PYTHAGORAS

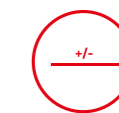

OPERATIONS

MEASURING, MARKING AND LEVELLING

LASER LEVELLING



▶ RED LASER LEVEL NIV20R

REF.	€	8 41 4299	g	A mm	B mm	C mm	m	Color	
NIV20R	86,23	710731	1	210	75	64	73	20	●
NIV20V	106,53	710748	1	210	75	64	73	20	●



▶ GREEN LASER LEVEL WITH PLUMB LINE NIV30V

REF.	€	8 41 4299	g	A mm	B mm	C mm	m	Color	
NIV30V	202,95	710755	1	365	113	60	95	30	●



▶ RED LASER LEVEL 3X3600 NIV30360R

REF.	€	8 41 4299	g	A mm	B mm	C mm	m	Color	
NIV30360V	405,95	713480	1	420	133	86	120	30	●
NIV30360R	304,45	710762	1	420	133	86	120	30	●



▶ GREEN 3X3600 LASER LEVEL FOR TILING WORK NIV30360V

REF.	€	8 41 4299	g	A mm	B mm	C mm	m	Color	
NIV30360VT	405,95	039023	1	420	145	330	290	30	●

NEW



▶ BATTERY NIVBAT

REF.	€	8 41 4299	g	A mm	B mm	C mm	
NIVBAT	30,40	710847	1	120	30	50	80



▶ MAGNETIC SUPPORT NIVMAN

REF.	€	8 41 4299	g	A mm	B mm	C mm	
NIVMAN	22,28	710823	1	270	100	60	130



▶ CLIP NIVPINZA

REF.	€	8 41 4299	g	A mm	B mm	C mm	
NIVPINZA	17,21	710854	1	300	70	90	190



▶ MAGNETIC HOLDER NIVSOPM

REF.	€	8 41 4299	g	A mm	B mm	C mm	
NIVSOPM	44,95	042696	20	300	100	60	130

NEW



▶ 1.5M TRIPOD NIVTRIP015

REF.	€	8 41 4299	g	A mm	B mm	C mm
NIVTRIP015	37,51	710830	1	1.100	1.000	1.500

LASER MEASUREMENT



▶ LASER METER MED50R

REF.	€	8 41 4299	g	A mm	B mm	C mm	m	Color	
MED50R	71,00	710724	1	110	25	50	111	50	●

LONG TAPES

- Long life and maximum resistance.
- Housing highly resistant to impacts and ergonomic design for an improved grip and handling: easy to use.
- Marked with a millimetre scale.
 - 50021/50022: fiberglass tape, very resistant, flexible and washable.
 - 50023: Carbon steel tape covered in nylon, maximum durability and easier to read tape.
- Folding steel hook, easy to fix different surfaces.

Uses:

- For long distance measuring jobs.



▶ LONG TAPE 50021

REF.	€	8 41 4299	g	A mm	B mm	C mm	L mm
50021-10	12,94	447040	6	200	100	25	100
50021-20	16,85	618068	6	300	130	25	130
50021-30	21,85	618082	6	420	160	25	160
50021-50	28,38	618105	6	660	200	25	200

24 thread fiberglass tape. Marked in both sides of the tape. Plastic anti-slip base. With back handle in 30 and 50 m.

* 50021-10 UNTIL END OF STOCK.



▶ MEASURING TAPE 50022

REF.	€	8 41 4299	g	A mm	B mm	C mm	L mm
50022-30	34,53	618129	2	940	220	40	300
50022-50	46,57	618143	2	1.250	350	40	270

40 thread fiberglass tape, very resistant. Marked in both sides of the tape. Open ABS case with a grip ergonomic area. Fast retracting x3



▶ METALIC LONG TAPE 50023

REF.	€	8 41 4299	g	A mm	B mm	C mm	L mm
50023-20	32,21	618167	6	400	125	30	125
50023-30	40,31	618181	6	480	125	30	125

High precision steel tape. Class II. Anti-impact compact case covered with leather. Metal strap. Nylon coating. Metal casing. Class II certified.

* 50023-20, 50023-30 UNTIL END OF STOCK.

SHORT TAPES

- Special chrome tape, long life and maximum resistance, high torsion-resistance.
- Steel tape covered in a matt varnish or in nylon, maximum durability and easier to read tape.
- Housing highly resistant to impacts and ergonomic design for an improved grip and handling: easy to use.
- A highly resistant pointed hook with several rivets, depending on product.
- Tape retracting absorption, to keep the hook from being damaged.
- Clip to fasten the tape to a belt.
- Label with a space for identification and personalisation.

Uses:

- For measuring jobs.



▶ STAINLESS STEEL BIMATERIAL SHORT TAPE 50014

REF.	€	8 41 4299	g	A mm	B mm	C mm	L mm
50014-3	4,59	706437	24	120	63	30	68
50014-5	6,13	706451	12	200	70	35	70
50014-8	10,25	706475	12	390	80	40	80
50014-5 IMP	7,16	706512	12	200	70	35	70 5m/16'
50014-8 IMP	10,25	706536	12	390	80	40	80 8m/26'

Hook with 2 rivets. Highly impact-resistant plastic and rubber housing. Shock resistant. IMP: marking in mm and inches.

* 500145IMP - 500148IMP UNTIL END OF STOCK.



▶ STAINLESS STEEL BIMATERIAL SHORT TAPE 50014

REF.	€	8 41 4299	g	A mm	B mm	C mm	L mm
50014M-5	7,16	706499	12	200	75	35	70



▶ CHROMED SHORT TAPE 50012

REF.	€	8 41 4299	g	A mm	B mm	C mm	L mm
50012-5 BL	12,32	618280	6	230	70	40	70
50012-8 BL	18,45	618327	6	380	80	40	80

25 mm wide tape. Marked in both sides of the tape. Hook with 3 extra-grip rivets. Lower Block button



▶ CHROMED SHORT TAPE WITH MAGNET 50012

REF.	€	8 41 4299	g	A mm	B mm	C mm	L mm
50012M-5 BL	14,14	618303	6	210	70	38	70

50012 with maximum magnetic tip with two ferrite magnets coated with an anti-slip rubber maimum durability.



▶ STAINLESS STEEL BIMATERIAL SHORT TAPE 50013

REF.	€	8 41 4299	g	A mm	B mm	C mm	L mm
50013-5 BL	19,67	618341	6	370	70	50	70
50013-8 BL	23,04	618365	6	500	80	55	80

33 mm wide tape. Up to 3 meters without bending. Hook with 5 extra-grip rivets. Bimaterial stainless steel case extremely impact-resistant.



▶ BI-MATERIAL FLEXOMETER 50015

REF.	€	8 41 4299	g	A mm	B mm	C mm	L mm
500155	12,95	005776	12	290	70	45	70

NEW

PENCILS

- Professional pencils: excellent marking and durability.
- High-Quality graphite leads, thickness from 4 mm to 7.5mm.

Uses:

- For marking tasks.

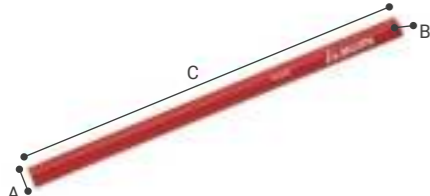

▶ CARPENTER PENCIL 50240

REF.	€	8 41 4299	g	A mm	B mm	C mm
50240	2,41	044744	50	10	240	13



▶ STONE PENCIL 50241

REF.	€	8 41 4299	g	A mm	B mm	C mm
50241	2,57	044782	50	10	240	13



▶ UNIVERSAL PENCIL 50243

REF.	€	8 41 4299	g	A mm	B mm	C mm
50243	6,49	044768	50	20	240	12



▶ WET SURFACES PENCIL 50244

REF.	€	8 41 4299	g	A mm	B mm	C mm
50244	2,23	044775	50	10	175	8

Weather resistant marking.



▶ 3 DUO PENCILS KIT 50245

REF.	€	8 41 4299	g	A mm	B mm	C mm
50245-3	9,86	565652	20	40	175	10

	DRY WOOD	WET WOOD	STONE/CONCRETE	METAL	CERAMICS	PLASTIC	GLASS
50240	▲▲▲	▲	▲	▲			
50241	▲	▲	▲▲▲	▲			
50243	▲▲	▲▲	▲▲	▲▲	▲▲▲	▲▲▲	▲
50244	▲▲▲	▲▲▲	▲▲	▲▲	▲	▲▲▲	▲
50245	▲▲	▲▲	▲▲	▲	▲	▲▲▲	

- ▲▲▲ Optimal performance
- ▲▲ Excellent performance
- ▲ Good performance

BOX LEVELS

- Vial accuracy +/- 0.5 mm/m. Impact resistant vials and UV ray resistant. 15 year guarantee.
- Milled surfaces for greater precision and use both sides.
- Reinforced tubular profile for high strength.
- Shock absorbing rubber end caps mono-material (50101) or Bi-material (50107).

Uses:

- For levelling jobs.



▶ BOX LEVEL 50101

REF.	€	8 41 4299	g	A mm	B mm	C mm
50101-30	17,88	600346	5	200	50	20
50101-40	19,61	600353	5	250	50	20
50101-50	20,86	600360	5	300	50	20
50101-60	22,63	600377	5	360	50	20
50101-80	25,43	600384	5	460	50	20
50101-100	28,99	600391	5	566	50	20
50101-120	35,56	611502	5	672	50	20
50101-150	42,30	611526	1	836	50	20
50101-180	50,32	611540	1	1.032	80	40
50101-200	57,11	611564	1	1.240	80	40

Two vials, vertical and horizontal.



▶ MAGNETIC BOX LEVEL 50101

REF.	€	8 41 4299	g	A mm	B mm	C mm
50101M-40	24,52	611601	5	280	50	20
50101M-50	26,91	611625	5	340	50	25
50101M-60	29,15	611649	5	390	50	20
50101M-80	34,06	611663	5	480	50	20
50101M-100	38,84	611687	5	600	50	20
50101M-120	46,20	611700	5	780	50	20
50101M-30	22,34	611588	5	230	50	20

50101 Level with ultra strong neodymium magnets. Up to 4 magnets in lengths over 60 cm.



▶ EXTRA BOX LEVEL 50107

REF.	€	8 41 4299	g	A mm	B mm	C mm
50107-40	31,24	611724	5	440	60	25
50107-60	40,78	503760	5	610	60	25
50107-80	44,31	503821	5	790	60	25
50107-100	49,94	611779	5	930	60	25
50107-120	52,63	611793	5	1.100	60	25

Extrawide profile with reinforced handles for greater comfort. Three vials vertical and horizontal.



▶ MAGNETIC EXTRA BOX LEVEL 50107

REF.	€	8 41 4299	g	A mm	B mm	C mm
50107M-40	42,25	611816	5	400	60	25
50107M-60	55,08	611830	5	660	60	25
50107M-80	59,85	611854	5	810	60	25
50107M-100	72,42	611878	5	960	60	25
50107M-120	76,32	611892	5	1.180	60	25

50107 Level with ultra strong neodymium magnets, up to 4 magnets in lengths over 80 cm.



▶ TORPEDO MAGNETIC LEVEL 50109

REF.	€	8 41 4299	g	A mm	B mm	C mm
50109-9	8,09	324594	10	90	38	20

V ridge for easy reading in pipes and similar places. 1 mm/m precision.

CAST LEVELS

- Vial accuracy +/- 0.5 mm/m . Impact resistant vials and UV ray resistant. 15 year guarantee.
- Milled surfaces for greater precision.
- Aluminium cast profile high resistant.

Uses:

- For levelling jobs.



▶ TRAPEZOIDAL CAST LEVEL 50102

REF.	€	8 41 4299	g	A mm	B mm	C mm	
50102-40	36,13	600407	5	380	42	21	400
50102-50	39,10	600414	5	540	42	21	500
50102-60	43,69	600421	5	490	42	21	600
50102-80	52,21	600438	5	780	42	21	800

2 vials vertical and horizontal.



▶ MAGNETIC TRAPEZOIDAL CAST LEVEL 50106

REF.	€	8 41 4299	g	A mm	B mm	C mm	
50106-60	68,88	564976	5	510	45	20	600

50102 Level with ultra strong neodymium magnets.



▶ DOUBLE T CAST LEVEL 50103

REF.	€	8 41 4299	g	A mm	B mm	C mm	
50103-60	53,48	942705	5	820	50	23	600
50103-80	64,09	942736	5	970	50	23	800

3 vials vertical and horizontal. With handle for greater comfort. * AVAILABLE UNTIL END OF STOCK.

SQUARES

- Maximum resistance, durable and precision.
- Stainless steel square, with a reinforced anodised aluminium tip.

Uses:

- For measuring and marking jobs.

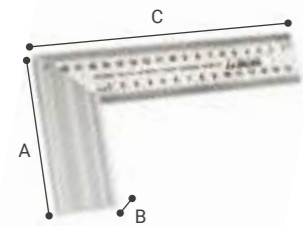

▶ STAINLESS STEEL SQUARE 50215

REF.	€	8 41 4299	g	A mm	B mm	C mm	
50215-200	31,92	040142	6	150	115	15	200
50215-250	35,15	040173	6	190	140	15	253
50215-300	38,40	040203	6	230	165	15	300
50215-400	41,52	040234	6	260	165	15	400

CHALK LINES

- Very resistant and compact aluminium or polypropylene box.
- Ergonomic shape for better grip.
- Fast and easy filling device, does not require opening or closing (ref.50221).
- 30 m string with high tracing powder retention.
- Crank string locking system.
- Steel hook, easy to fix on different surfaces.

Uses:

- For marking jobs.

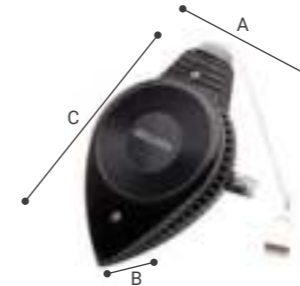

▶ ALUMINIUM CHALK LINE 50220

REF.	€	8 41 4299	g	A mm	B mm	C mm	
50220	15,57	040104	6	230	75	30	125

Easy fill.



▶ BIMATERIAL CHALK LINE 50221

REF.	€	8 41 4299	g	A mm	B mm	C mm	
50221	15,12	040128	6	160	80	40	135

Semi-transparent case for complete powder visibility, to see when it needs powder filling. 50221-2 Double box.



▶ BIMATERIAL CHALK LINE KIT 50222

REF.	€	8 41 4299	g	A mm	B mm	C mm	
50222	17,40	040081	6	370	190	55	250

50221 Blue chalk powder 113 grs. Easy fill.



▶ ALUMINIUM CHALK LINE KIT 50223

REF.	€	8 41 4299	g	A mm	B mm	C mm	
50223	18,31	046106	6	440	140	50	160

50220 + Blue chalk powder 113 grs. Easy fill.



▶ 500 GRs. BLUE CHALK POWDER 50230

REF.	€	8 41 4299	g	A mm	B mm	C mm	
50230	8,66	040043	6	590	80	80	222

PLUMB BOB AND MAGNETIC SQUARES

Plumb bob:

- Made with top quality materials for long life damage free.
- Plumb, screw and plate made of galvanized steel to prevent rust.

Uses:

- To check and align vertical elements on building sites, such as walls and pillars.

Square:

- Anodised aluminium square with strong neodymium magnet.
- Quick clamping device string. very resistant 15 m of nylon string.

Uses:

- For aligning bricks during bricklaying, making builders work easier.



► PLUMB BOB 50250

REF.	€	8 41 4299	g	A mm	B mm	C mm	
50250-200	12,98	057683	4	300	180	45	200
50250-500	16,56	069532	4	780	180	45	200

► MAGNETIC SQUARES 50251

REF.	€	8 41 4299	g	A mm	B mm	C mm	
50251	23,01	612851	4	275	90	43	140

CUTTING

DIAMOND DISCS DRY CUTTING

- Top quality, large, octagonal shaped diamonds for maximum performance and service life of the disc.
- Diamonds are homogenous so that they are all of the same quality right around the rim of the disc.
- Perfect joint between the core and segment which makes two parts into a single element.
- Laser marking prevents information from being lost or the disc blade slowing down or becoming blunt.
- Different types of segments:
 - Turbo discs provides greater finishing quality and cleaner cutting than segmented discs.
 - Continuous Fand discs ensure a fine and a accurate cutting.

Uses:

- To use in air cooled portable machines.
- General purpose: cutting of materials not having extreme values of hardness or abrasion: roof tiles, terrazzo, bricks, concrete blocks, hydraulic tiles, etc.
- Hard materials: cutting of materials with extreme values of hardness and average abrasion: granite, klinker, quartzite, porphyry, refractory brick, cured concrete, etc.
- Abrasive materials: cutting of materials not very hard, but wearing out discs quickly because of their highly abrasive capacity: blocks, old concrete, silica terrazzo, asphalt, normal brick, sandstone, etc.
- Ceramics materials: cutting of ceramic and porcelain materials.

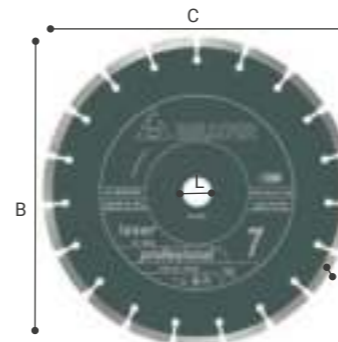

► DIAMOND DISC GENERAL PURPOSE. LASER. PROFESSIONAL 50702

REF.	€	8 41 4299	g	A mm	B mm	C mm	L mm	M box	D mm	N°	E mm	
50702-115	29,98	051452	1	120	10	115	115	11	4	22,2	7	2,4
50702-125	32,65	051476	1	140	2	125	125	11	4	22,2	8	2,4
50702-230	61,01	051513	1	590	3	230	230	11	4	22,2	15	2,6



► DIAMOND DISC GENERAL PURPOSE. TURBO. PROFESSIONAL 50703

REF.	€	8 41 4299	g	A mm	B mm	C mm	L mm	M box	D mm	E mm	
50703-115	18,19	051537	1	100	2	115	115	7	4	22,2	2
50703-125	20,24	051551	1	110	2	125	125	7	4	22,2	2,4
50703-230	46,03	051599	1	540	3	230	230	7	4	22,2	2,6



► DIAMOND DISC GENERAL PURPOSE. LASER. PRO 50711

REF.	€	8 41 4299	g	A mm	B mm	C mm	L mm	M box	D mm	N°	E mm	
50711-115	17,52	405453	1	100	2	115	115	7	4	22,2	9	1,8
50711-125	26,85	405484	1	120	2	125	125	7	4	22,2	10	1,8
50711-180	37,87	405514	1	310	3	180	180	7	4	22,2	14	2,2
50711-230	42,17	405545	1	520	3	230	230	7	4	22,2	16	2,4



► DIAMOND DISC GENERAL PURPOSE. TURBO. PRO 50712

REF.	€	8 41 4299	g	A mm	B mm	C mm	L mm	M box	D mm	E mm	
50712-115	17,15	405576	1	100	2	115	115	7	4	22,2	2
50712-125	19,99	405613	1	120	2	125	125	7	4	22,2	2,4
50712-180	32,98	405644	1	320	3	180	180	7	4	22,2	2,4
50712-230	44,75	405675	1	540	2,5	230	230	7	4	22,2	2,6



▶ DIAMOND DISC HARD MATERIALS. LASER. PROFESSIONAL 50704

REF.	€	8 41 4299	g	A mm	B mm	C mm	L mm	Mbox	D mm	Nº	E mm
50704-115	29,15	051612	1	120	3	115	115	11	4	22,2	7 2,4
50704-125	33,35	051636	1	150	2	125	125	11	4	22,2	8 2,4
50704-230	59,97	051674	1	580	3	230	230	11	4	22,2	15 2,6



▶ DIAMOND DISC HARD MATERIALS. TURBO. PROFESSIONAL 50705

REF.	€	8 41 4299	g	A mm	B mm	C mm	L mm	Mbox	D mm	Nº	E mm
50705-115	20,26	051698	1	120	2	115	115	10	4	22,2	2,2
50705-125	25,18	051711	1	140	2	125	125	10	4	22,2	2
50705-230	49,99	051759	1	560	3	230	230	10	4	22,2	2,6



▶ DIAMOND DISC ABRASIVE MATERIALS. LASER. PROFESSIONAL 50706

REF.	€	8 41 4299	g	A mm	B mm	C mm	L mm	Mbox	D mm	Nº	E mm
50706-230	85,44	051773	1	610	3	230	230	13	4	22,2	16 2,6
50706-350	181,79	051810	1	1.790	3	350	350	13	20	25,4	21 3,2



▶ DIAMOND DISC ABRASIVE MATERIALS. TURBO. PROFESSIONAL 50707

REF.	€	8 41 4299	g	A mm	B mm	C mm	L mm	Mbox	D mm	Nº	E mm
50707-230	50,14	051834	1	580	3	230	230	10	4	22,2	2,6



▶ DIAMOND DISC CERAMIC. CONTINUOUS RIM. PROFESSIONAL 50722

REF.	€	8 41 4299	g	A mm	B mm	C mm	L mm	Mbox	D mm	Nº	E mm
50722-115	21,24	222838	1	100	1	115	115	7	4	22,2	1,5
50722-125	24,18	222890	1	120	2	125	125	7	4	22,2	1,5

For use on floors and walls, both interior and exterior.



▶ DIAMOND DISC CERAMIC. CONTINUOUS RIM. PROFESSIONAL 50734

REF.	€	8 41 4299	g	A mm	B mm	C mm	L mm	Mbox	D mm	Nº	E mm
50734-115	29,98	525670	1	100	2	115	115	7	4	22,2	1,6
50734-125	35,35	525700	1	120	2	125	125	7	4	22,2	1,6

Porcelain tile, is a ceramic material that, unlike other ceramics, absorbs very little water, which makes it harder.



▶ THIN PORCELAIN DIAMOND CUTTING DISC 50734-S

REF.	€	8 41 4299	g	A mm	B mm	C mm	L mm	Mbox	D mm	Nº	E mm
50734-S115	32,15	623192	1	100	2	115	115	10	4	22,2	1,2
50734-S125	37,78	641325	1	120	2	125	125	10	4	22,2	1,2



▶ DIAMOND DISC REINFORCED CONCRETE. LASER. PROFESSIONAL 50735

REF.	€	8 41 4299	g	A mm	B mm	C mm	L mm	Mbox	D mm	Nº	E mm
50735-230	106,94	569308	1	590	3	230	230	13	4	22,2	2,6

It is a hard material because of the effect of the reinforcement, which conditions the composition of the binders of the disc.

DIAMOND DISCS WET CUTTING

- Top quality, large, octagonal shaped diamonds for maximum performance and service life of the disc.
- Diamonds are homogenous so that they are all of the same quality right around the rim of the disc.
- Perfect joint between the core and segment which makes two parts into a single element.
- Laser marking that prevents information from being lost or the disc blade slowing down or becoming blunt.

Uses:

- For stationary machines both water-cooled diamond cutting tables and ceramic cutting.
- General purpose: cutting of materials not having extreme values of hardness or abrasion: roof tiles, terrazzo, bricks, concrete blocks, hydraulic tiles, etc.
- Hard materials: cutting of materials with extreme values of hardness and average abrasion: granite, klinker, quartzite, porphyry, refractory brick, cured concrete, etc.
- Ceramics materials: cutting of ceramic and porcelain materials.



▶ DIAMOND DISC GENERAL PURPOSE. LASER. PROFESSIONAL 50708

REF.	€	8 41 4299	g	A mm	B mm	C mm	L mm	Mbox	D mm	Nº	E mm
50708-300	181,66	051896	1	1.020	3	300	300	11	1000	25,4	20 2,8
50708-350	235,73	051919	1	1.680	3	350	350	11	1000	25,4	24 3,2



▶ DIAMOND DISC GENERAL PURPOSE. LASER. PROFESSIONAL 50713

REF.	€	8 41 4299	g	A mm	B mm	C mm	L mm	Mbox	D mm	Nº	E mm
50713-300	109,07	405712	1	1.010	3	300	300	11	384	25,4	20 2,8
50713-350	133,79	314236	1	1.630	3	350	350	11	1000	25,4	21 3



▶ DIAMOND DISC HARD MATERIALS. LASER. PROFESSIONAL 50724

REF.	€	8 41 4299	g	A mm	B mm	C mm	L mm	Mbox	D mm	Nº	E mm
50724-300	147,82	223491	1	1.300	2	300	300	13	1000	25,4	18 2,8
50724-350	205,68	223569	1	1.770	3	350	350	13	1	25,4	21 3

Among these materials are granite, klinker, quartzite, porphyry, cured concrete, etc.



▶ DIAMOND DISC PORCELAIN. CONTINUOUS RIM. PROFESSIONAL 50732

REF.	€	8 41 4299	g	A mm	B mm	C mm	L mm	Mbox	D mm	Nº	E mm
50732-180	41,23	373479	1	240	2	180	180	7	4	25,4	1,9
50732-230	70,64	373486	1	400	2	230	230	7	120	25,4	1,9
50732-300	97,94	373493	1	1.010	3	300	300	7	1000	25,4	2
50732-350	118,72	373516	1	1.500	3	350	350	7	16	25,4	2

Porcelain tile, commonly called porcelain, is a ceramic material that, unlike other ceramics, absorbs very little water, which makes it harder.

DIAMOND DRILL BITS



DIAMOND DRILL BITS M14 50750

REF.	€	8 41 4299	g	A mm	B mm	C mm	L mm
507506	20,91	649963	10	130	35	35	120
507508	24,03	649987	1	140	35	35	120
5075010	25,97	650006	10	140	35	35	120
5075012	28,39	650020	1	140	35	35	120
5075014	31,05	650044	10	150	35	35	120
5075015	31,77	650068	10	150	35	35	120
5075018	39,02	650082	10	150	35	35	120
5075020	42,16	650105	1	160	35	35	120
5075022	45,80	650129	10	170	35	35	120
5075025	49,17	650143	1	180	35	35	120
5075035	61,96	650167	10	290	52	52	125
5075045	70,90	650181	10	340	52	52	125
5075050	81,52	650204	10	360	52	52	125
5075060	96,49	650228	1	520	73	73	125
5075065	102,28	650242	10	550	73	73	125
5075068	108,07	653670	10	570	73	73	125
5075028	52,89	065145	1	120	45	45	120
5075080	113,38	670455	1	570	73	73	125

DIAMOND DRILL BITS HEX6,5 50751

REF.	€	8 41 4299	g	A mm	B mm	C mm	L mm
507516	21,40	650280	10	110	35	35	120
507518	23,57	650303	10	110	35	35	120
5075110	25,25	650327	10	110	35	35	120
5075112	27,44	650341	10	120	35	35	120
5075114	30,09	650365	10	120	35	35	120



KIT DIAMOND DRILL BITS M14 50750KIT

REF.	€	8 41 4299	g	A mm	B mm	C mm	L mm
50750KIT	101,32	650389	1	710	200	140	90



KIT DIAMOND DRILL BITS HEX6,5 50751KIT

REF.	€	8 41 4299	g	A mm	B mm	C mm	L mm
50751KIT	98,91	650402	4	940	200	140	90



KIT DIAMOND DRILL BITS M14 50750KIT

REF.	€	8 41 4299	g	A mm	B mm	C mm	L mm
50750KIT1	197,48	656602	1	720	200	150	80



ADAPTOR FROM M14 TO HEX12 50750M14

REF.	€	8 41 4299	g	A mm	B mm	C mm	L mm
50750M14	9,66	650266	1	150	52	52	125



GUIDE FOR DRY CUT DRILL BITS 50750 M14

REF.	€	8 41 4299	g	A mm	B mm	C mm	L mm
50750GUIDE	28,62	656640	1	180	70	70	125

FLEXIBLE DIAMOND POLISHING DISCS



NEW



NEW

FLEXIBLE DIAMOND DISC DFDIAM

REF.	€	8 41 4299	g	A mm	B mm	C mm
DFDIAM100	9,95	050639	6	25	100	100
DFDIAM200	9,95	050820	6	25	100	100
DFDIAM400	9,95	051117	6	25	100	100
DFDIAM800	9,95	051377	6	25	100	100
DFDIAM1500	9,95	050738	6	25	100	100
DFDIAM3000	9,95	051094	6	25	100	100
DFDIAMA	9,95	049664	6	25	100	100

HOLDER FOR FLEXIBLE DIAMOND DISCS DFDIAMS14

REF.	€	8 41 4299	g	A mm	B mm	C mm
DFDIAMS14	11,95	049695	6	151	93	93

DIAMOND POLISHING BLOCKS



NEW

DIAMOND BLOCK FOR GRINDING AND EDGE POLISHING WORK TDIAM

REF.	€	8 41 4299	g	A mm	B mm	C mm
TDIAM60	19,95	045949	15	23	92	58
TDIAM120	19,95	046007	15	23	92	58
TDIAM200	19,95	046083	15	23	92	58
TDIAM400	19,95	046526	15	23	92	58

CLEANING

PRESSURE WASHERS



► HIGH PRESSURE WASHER 120 BAR HL1400E

REF.	€	8 41 4299	g	A mm	B mm	C mm	Kw	bar	l/h
HL1400E	110,60	032680	1	5.000	295	270	400	1,4	120

NEW



► HIGH PRESSURE WASHER 140 BAR HL1700E

REF.	€	8 41 4299	g	A mm	B mm	C mm	Kw	bar	l/h
HL1700E	172,30	032819	1	9.000	307	307	651	1,7	140

NEW



► HIGH PRESSURE WASHER 150 BAR HL2400PROE

REF.	€	8 41 4299	g	A mm	B mm	C mm	Kw	bar	l/h
HL2400PROE	312,30	032833	1	19.000	360	400	770	2,4	150

NEW



► SYNCHRONOUS VACUUM FOR LIQUIDS AND SOLIDS ASL2500SE

REF.	€	8 41 4299	g	A mm	B mm	C mm	Kw	L	kPa
ASL2500SE	88,06	032666	1	6.700	345	345	590	2	25

NEW

VACUUM CLEANERS

ACCESSORIES FOR HIGH PRESSURE CLEANERS



► ACCESSORIES FOR HIGH PRESSURE CLEANERS HL1400E / HL1700E / HL2400PROE

REF.	€	8 41 4299	g	bar	l/h
AC59HL2400PRO	0,40	37968	1		HL2400PROE
AC61HL1400	9,32	34639	1		HL1400E
AC62HL1400	7,98	34738	1		HL1400E
AC66HL1400	19,33	35292	1		HL1400E / HL2400PROE / HL2400PROE
AC68HL1400	0,40	24807	1		HL1400E / HL1700E
AC80HL	21,31	76608	1		HL1400E / HL1700E
AC81HL	8,67	76646	1		HL1400E / HL1700E
AC82HL	8,67	76660	1		HL1400E / HL1700E
AC83HL	13,40	76707	1		HL1400E / HL1700E
AC84HL	6,84	76738	1		HL1400E / HL1700E / HL2400PROE
AC84HL1700	7,98	37111	1		HL1700E
AC85HL	2,48	76752	1		HL1400E / HL1700E / HL2400PROE
AC85HL1700	9,32	37135	1		HL1700E
AC85HL2400PRO	26,26	38279	1		HL2400PROE
AC86HL1700	25,74	37159	1		HL1700E
AC86HL2400PRO	12,47	38309	1		HL2400PROE
AC87HL2400PRO	10,96	38323	1		HL2400PROE
AC89HL2400PRO	38,42	38361	1		HL2400PROE
AC91HL2400PRO	8,24	38422	1		HL2400PROE
MSF3HL	25,82	49091	1		HL1400E / HL1700E / HL2400PROE

ACCESSORIES FOR VACUUM CLEANERS



► ACCESSORIES FOR VACUUM CLEANER ASL2500SE

REF.	€	8 41 4299	g	L	kPa
AC16ASL2500S	6,14	38750	1		ASL2500SE
AC20ASL2500S	7,68	38774	1		ASL2500SE
AC27ASL2500S	14,29	38866	1		ASL2500SE
AC38ASL2500S	16,82	38910	1		ASL2500SE
AC43ASL2500S	21,02	38941	1		ASL2500SE
AC44ASL2500S	10,23	38965	1		ASL2500SE
AC45ASL2500S	2,52	38989	1		ASL2500SE
AC46ASL2500S	2,52	39009	1		ASL2500SE



Tools that
bring life
to your project

**FOR
THE WORKSHOP**

SCREWDRIVERS

- Chrome-Molybdenum-Vanadium steel rod: very robust and resistant.
- Heat treatment and fully tempered shaft 59Hrc.
- Trilobular shape unequal tightening torque intensity, geometry to match the natural movement of the hand allowing 120° rotation.
- Three-materials ergonomic handles with SOFT TOUCH for comfort during work.
- Geometry of the socket to guarantee optimal connection preventing the shaft from turning in the handle.

Uses:

- For jobs involving tightening and removing screws.

CABINET TIP

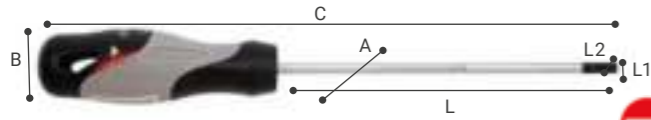

► CABINET TIP SCREWDRIVER 66200

REF.	€	g	A mm	B mm	C mm	L mm	L1 mm	L2 mm		
66200-3x75	3,67	148367	6	40	27	27	160	75	3	0,5
66200-3x100	3,80	148169	6	40	27	27	185	100	3	0,5
66200-3.5x100	4,09	148534	6	40	27	27	185	100	3,5	0,6
66200-4x100	4,71	148695	6	40	27	27	185	100	4	0,8
66200-4x125	4,56	148848	6	50	27	27	210	125	4	0,8
66200-5.5x125	5,86	148893	6	80	32	32	225	125	5,5	1
66200-5.5x150	6,65	148947	6	90	32	32	250	150	5,5	1
66200-6.5x150	7,90	148992	6	110	35	35	260	150	6,5	1,2

For jobs involving tightening and removing screws.

PHILIPS TIP



► PHILIPS TIP SCREWDRIVER 66220

REF.	€	g	A mm	B mm	C mm	L mm	L1 mm	L2 mm	
66220-PH0	4,36	149814	6	40	27	27	160	75	-
66220-PH1	5,39	149869	6	70	31	31	200	100	-
66220-PH2	6,62	149920	6	100	34	34	235	125	-
66220-PH3	10,51	149982	6	170	38	38	270	150	-

For jobs involving tightening and removing screws.

SCREWDRIVER KIT



► 6 SCREWDRIVER KIT-MECHANIC 66292

REF.	€	g	A mm	B mm	C mm		
66292-MEC	35,22	153170	4	590	165	45	310
66200-3x100			66200-4x125		66210-5,5x125		
66210-6,5x150			66220-PH1		66220-PH2		

► 6 SCREWDRIVER KIT-ELECTRICIAN 66291

REF.	€	g	A mm	B mm	C mm		
66291-ELEC	31,38	333060	4	470	165	40	310
66200-3x100			66200-4x125		66200-5,5x125		
66220-PH0			66220-PH1		66220-PH2		

STANDARD TIP



► STANDARD TIP SCREWDRIVER 66210

REF.	€	g	A mm	B mm	C mm	L mm	L1 mm	L2 mm		
66210-4x100	4,43	149319	6	40	27	27	185	100	4	0,8
66210-5.5x100	5,69	149364	6	80	32	32	200	100	5,5	1
66210-5.5x125	5,68	149425	6	80	32	32	225	125	5,5	1
66210-6.5x125	7,37	149470	6	100	35	35	235	125	6,5	1,2
66210-6.5x150	8,23	149531	6	110	34	35	260	150	6,5	1,2
66210-8x175	9,50	149647	6	150	36	38	300	175	8	1,2
66210-10x200	12,17	149692	6	180	38	38	320	200	10	1,6
66210-12x250	15,71	149753	6	230	35	38	370	250	12	2

For jobs involving tightening and removing screws.

POZIDRIV TIP



► POZIDRIV TIP SCREWDRIVER 66230

REF.	€	g	A mm	B mm	C mm	L mm	L1 mm	L2 mm	
66230-PZ0	5,32	150261	6	30	27	27	160	75	-
66230-PZ1	5,85	150315	6	70	32	32	200	100	-
66230-PZ2	7,13	150391	6	100	34	34	240	125	-
66230-PZ3	10,97	150452	6	170	38	38	270	150	-

For jobs involving tightening and removing screws.

WRENCHES

- Manufactured with Chrome-Vanadium steel.
- Forged in one single piece, unbreakable.
- 3+ steel treatment for a longer tool life: doesn't break, warp or wear away.
- Total size and opening setting accuracy.
- Torque strengths over 50% of the current standard.
- Wide openings, wide neck and greater head thickness for improved nut clamping.
- Complies with DIN standards

Uses:

- For varied torque and adjustment of nuts and bolts.

DOUBLE OPEN-END WRENCH

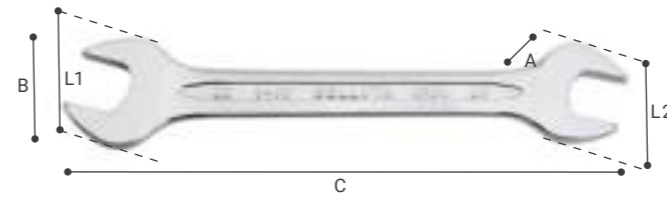

► DOUBLE OPEN-END WRENCH 6400

REF.	€	g	A mm	B mm	C mm	L1 mm	L2 mm		
6400-6x7	3,54	445558	6	20	4	15	120	15,8	17,5
6400-8x9	3,59	445619	6	30	4	21	130	19,4	21
6400-10x11	3,87	445671	6	60	5	26	150	23	25,1
6400-12x13	4,78	445749	6	70	5	30	168	27,5	30
6400-14x15	5,09	445800	6	140	5,5	20	145	30,4	32,3
6400-16x17	5,86	445862	6	130	6	37	200	33,4	35,9
6400-18x19	6,52	445930	6	180	7	40	216	38,7	40,4
6400-20x22	8,01	445992	6	210	7	45	235	43,6	48,2
6400-21x23	8,71	446081	6	260	8	50	240	46,3	49,6
6400-24x26	10,20	446173	6	350	8	55	260	52,7	56,8
6400-25x28	11,73	446210	6	400	9	60	267	54,5	59,5
6400-27x29	14,03	801231	6	440	9	60	267	55,4	59,5
6400-30x32	15,52	446296	6	510	10	65	296	61,5	65,4

DIN 3110 and DIN 475.



► 8 DOUBLE OPEN-END WRENCH KIT IN CLIP 6490

REF.	€	g	A mm	B mm	C mm	L1 mm	L2 mm
6490-8	45,22	781175	1	850	45	235	170
6400-6x7		6400-8x9		6400-10x11		6400-12x13	
6400-14x15		6400-16x17		6400-18x19		6400-20x22	
6490-10	67,34	781212	1	1.400	260	55	160
6400-6x7		6400-8x9		6400-10x11		6400-12x13	
6400-12x13		6400-14x15		6400-16x17		6400-18x19	
6400-18x19		6400-20x22		6400-21x23		6400-24x26	
6490-12	97,51	781250	1	2.440	290	67	185
6400-6x7		6400-8x9		6400-10x11		6400-12x13	
6400-12x13		6400-14x15		6400-16x17		6400-18x19	
6400-18x19		6400-20x22		6400-21x23		6400-24x26	
6400-24x26		6400-25x28		6400-30x32			



► 12 DOUBLE OPEN-END WRENCH KIT IN BAG 6490

REF.	€	g	A mm	B mm	C mm	L1 mm	L2 mm
6490-8 BS	46,61	018400	1	830	60	60	290
6400-6x7		6400-8x9		6400-10x11		6400-12x13	
6400-14x15		6400-16x17		6400-18x19		6400-20x22	

COMBINATION WRENCH

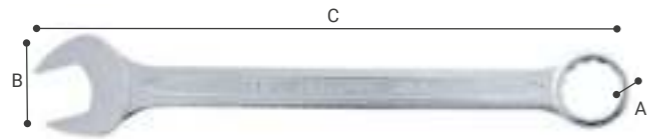

► COMBINATION WRENCH 6410

REF.	€	g	A mm	B mm	C mm	L1 mm	L2 mm		
6410-6	4,79	446456	6	20	5	15	100	16	10,6
6410-7	4,79	446524	6	20	5	15	110	16,8	11,6
6410-8	4,92	446586	6	30	6	15	120	18,8	12,8
6410-9	5,91	446647	6	40	7	20	130	20,9	14,4
6410-10	5,98	446715	6	40	7	20	139	22,6	16
6410-11	6,52	446777	6	50	10	23	150	24	17,2
6410-12	6,88	446838	6	60	11	27	160	25,4	18,5
6410-13	7,09	446890	6	80	13	27	170	28,1	20,2
6410-14	7,43	446968	6	90	13	30	180	30,1	21,2
6410-15	7,63	447026	6	90	15	30	190	32,1	23
6410-16	8,21	447088	6	110	15	34	200	34,2	24,4
6410-17	8,76	447187	6	130	13	35	210	36	25
6410-18	9,23	447248	6	150	12	35	220	37,5	27,5
6410-19	10,40	447316	6	180	15	40	230	40,2	28,6
6410-20	10,65	447392	6	190	15	40	240	41,4	30,4
6410-21	12,05	447446	6	200	16	42	245	43,2	31,8
6410-22	12,46	447484	6	250	20	45	255	45,8	33

DIN 3113 and DIN 475.



► 8 COMBINATION WRENCH KIT IN CLIP 6491

REF.	€	g	A mm	B mm	C mm	L1 mm	L2 mm
6491-8	70,28	781298	1	800	260	36	130
6410-8		6410-10		6410-11			
6410-13		6410-14		6410-17			
6410-19		6410-22					
6491-12	98,76	781373	1	1.210	40	254	225
6410-8		6410-9		6410-10			
6410-11		6410-12		6410-13			
6410-14		6410-15		6410-16			
6410-17		6410-19		6410-22			

DOUBLE RING END WRENCH

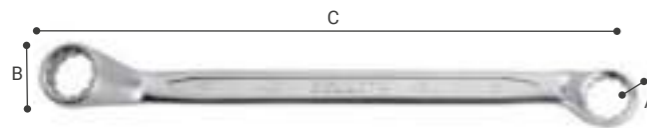

► DOUBLE RING END WRENCH 6420

REF.	€	g	A mm	B mm	C mm	L1 mm	L2 mm		
6420-6x7	7,77	447958	6	50	20	10	180	10,5	11,4
6420-8x9	8,50	447996	6	70	22	12	190	13,2	14,5
6420-10x11	9,09	448030	6	100	25	16	205	16,8	17,9
6420-12x13	9,67	448078	6	130	25	20	225	19,5	20,6
6420-14x15	10,40	448115	6	150	30	20	235	22,2	23
6420-16x17	12,54	448153	6	190	30	22	274	24,8	26
6420-18x19	14,39	448191	6	270	35	30	300	28,2	29,2
6420-20x22	16,55	448238	6	300	35	31	295	30,9	31,8
6420-21x23	18,65	448276	6	370	36	40	330	32	33,8
6420-24x26	23,06	448382	6	430	38	35	340	36,7	40,9

DIN 837 and DIN 475.



► 8 DOUBLE RING END WRENCH KIT IN CLIP 6492

REF.	€	g	A mm	B mm	C mm	L1 mm	L2 mm
6492-8	88,44	781410	1	1.300	330	35	130
6420-6x7		6420-8x9		6420-10x11			
6420-12x13		6420-14x15		6420-16x17			
6420-18x19		6420-20x22					

DOUBLE HEAD SOCKET WRENCH

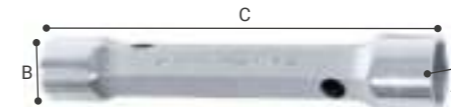

► DOUBLE HEAD SOCKET WRENCH 6440

REF.	€	g	A mm	B mm	C mm	L1 mm	L2 mm		
6440-6x7	9,72	449266	6	40	10	105	10	11	
6440-8x9	9,89	449310	6	60	13	13	110	13	14
6440-10x11	10,17	449358	6	90	15	15	120	15	16
6440-12x13	11,93	449396	6	140	18	18	140	18	19
6440-14x15	13,85	449433	6	100	20	22	185	20	22
6440-16x17	16,01	449471	6	190	23	24	155	23	24
6440-18x19	19,13	449518	6	240	25	26	165	25	26
6440-20x22	21,74	449556	6	300	28	30	170	28	30
6440-21x23	24,13	449594	6	340	30	31	185	29	31
6440-24x26	25,79	449693	6	410	33	35	185	33	35
6440-25x28	29,70	449730	6	480	34	37	205	34	37
6440-30x32	38,16	449815	6	640	40	42	210	40	42

It is possible to use with double open-end or adjustable



► DOUBLE HEAD SOCKET WRENCH KIT IN BAG 6495

REF.	€	g	A mm	B mm	C mm	L1 mm	L2 mm
6495-6 BS	57,66	618600	1	440	55	55	283
6441-6x7		6441-8x9		6441-10x11			
6441-12x13		6441-14x15		6441-16x17			



► DOUBLE HEAD SOCKET WRENCH 6441

REF.	€	g	A mm	B mm	C mm	L1 mm	L2 mm		
6441-6x7	6,70	641905	6	30	10	11	110	10	11
6441-8x9	7,32	618587	6	40	10	10	120	12,5	13,5
6441-10x11	7,64	618617	6	50	12	12	125	14,5	16
6441-12x13	8,95	618648	6	70	15	15	136	17	18
6441-14x15	9,16	641936	6	70	18	18	137	19	20
6441-16x17	10,04	641967	6	120	21	21	146	22	23
6441-17x19	11,76	641998	6	140	25	25	165	23	28
6441-21x23	14,16	642025	6	190	27	27	167	28	30



► 6 DOUBLE HEAD SOCKET WRENCH KIT IN BAG 6494

REF.	€	g	A mm	B mm	C mm	L1 mm	L2 mm
6494-6 BS	81,13	029741	1	850	180	26	170
6440-6x7		6440-8x9		6440-10x11			
6440-12x13		6440-14x15		6440-16x17			
6494-8 BS	112,47	029765	1	1.290	90	90	230
6440-6x7		6440-8x9		6440-10x11			
6440-12x13		6440-14x15		6440-16x17			
6440-18x19		6440-20x22					

STILLSON WRENCH

- Manufactured with special Bellota steel.
- Minimum tooth hardness 55 Hrc.
- Double T cross-section handle: robust, strong and ergonomic.
- Blue steel finishing of use and contact areas.
- Complies with GGG-W-00651d (GSA-FSS) standards type 2 class A.

Uses:

- To loosen or tighten large pieces.
- For plumbing work.

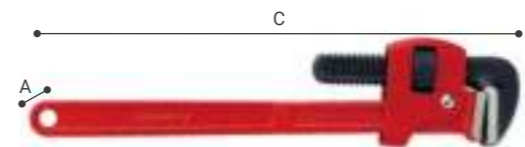

► STILLSON WRENCH 6600

REF.	€	g	A mm	B mm	C mm	L mm	L1 mm	L2 mm		
6600-8	21,14	967326	6	290	20	50	190	200	27	17
6600-10	24,86	967364	6	560	25	62	225	250	34	22
6600-12	27,52	967401	6	750	27	65	265	310	42	25
6600-14	34,28	967449	6	1.080	30	80	320	350	49	27
6600-18	42,15	967487	1	1.790	40	87	410	450	60	30
6600-24	69,61	967524	1	2.930	50	110	535	600	76	38
6600-36	129,15	967562	1	5.880	53	130	820	900	102	48

ADJUSTABLE WRENCH

- Manufactured inwith Chrome-vanadium steel.
- Forged in one single piece, unbreakable.
- 3+ steel treatment for a longer tool life: doesn't break, warp or wear away.
- Total size and opening setting accuracy.
- Torque strengths over 30% of the current standard.
- Thin and longer openings to access difficult places.
- Perfectly straight, fully adjustable.
- Double T cross-section handle: robust, strong and ergonomic.
- Complies with UNE 16-532 standards.

Uses:

- For varied torque and adjustment of nuts and bolts.

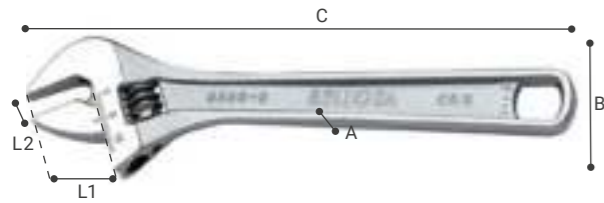

▶ ADJUSTABLE WRENCH 6460

REF.	€	8 41 4299	g	A mm	B mm	C mm	L1 mm	L2 mm
6460-6	20,31	451504	6	120	10	42	150	19,3
6460-8	23,37	451542	6	230	10	50	200	24
6460-10	28,29	451580	6	390	12	61	250	28,9
6460-12	37,37	451627	6	660	20	80	305	36
6460-15	54,43	451665	1	1.140	20	95	375	46



▶ SIDE NUT ADJUSTABLE WRENCH 6464

REF.	€	8 41 4299	g	A mm	B mm	C mm	L1 mm	L2 mm
6464-6	28,97	114430	6	150	12	52	152	18
6464-8	31,10	114133	6	270	12	65	205	26
6464-10	37,20	114317	6	500	15	80	260	32
6464-12	49,27	114379	6	820	20	93	307	36
6464-16	72,21	576245	1	1.510	25	117	405	48

PATENTED UN 167063.



NEW

▶ CENTRAL NUT ADJUSTABLE WRENCH BI-MATERIAL 26461

REF.	€	8 41 4299	g	A mm	B mm	C mm	L1 mm	L2 mm
2646108	20,31	710045	6	300	15	80	260	73,3
2646110	23,37	710069	6	550	15	80	260	98

ALLEN

- Manufactured in/with Chrome-Vanadium steel.
- Strong 50HRc, for maximum durability.
- Chamfered facilitating the key to fit into the screw.
- Complies with ISO 2936 standards.

Uses:

- For Allen torque and adjustment of nuts and bolts.

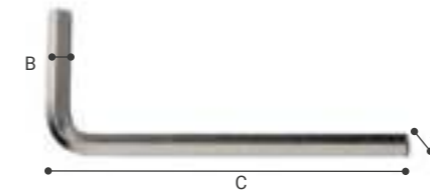

▶ NICKEL PLATED HEX KEY 6450

REF.	€	8 41 4299	g	A mm	B mm	C mm
6450-1.5 N	0,71	449853	12	5	1,5	15
6450-2 N	0,72	449914	12	8	2	18
6450-2.5 N	0,78	449952	12	10	2,5	19
6450-3 N	0,80	449990	12	10	3	21
6450-4 N	0,96	450033	12	10	5	27
6450-5 N	1,15	450071	12	20	5	34
6450-6 N	1,38	450118	12	30	7	37
6450-7 N	1,76	450156	12	40	6	40
6450-8 N	1,89	450194	12	60	8	45
6450-9 N	2,60	450231	12	70	9	45
6450-10 N	2,81	450279	12	100	11	45
6450-12 N	4,18	450446	1	170	12	55
6450-14 N	5,25	509120	1	270	15	70



▶ 8 HEX KEYS IN FOLDING SET 6455

REF.	€	8 41 4299	g	A mm	B mm	C mm
6455-8	16,75	618976	6	170	25	42
1,5		2				2,5
3		4				5
6		8				



▶ 9 HEX ROUND HEAD KEYS KIT 6457

REF.	€	8 41 4299	g	A mm	B mm	C mm
6457-9 P	22,01	507218	6	450	42	70
1,5		2				2,5
3		4				5
6		8				10



▶ 9 TORX KEYS KIT 6459

REF.	€	8 41 4299	g	A mm	B mm	C mm
6459-9 TIP	23,98	610284	6	260	45	65
T9		T10				T15
T20		T25				T27
T30		T40				T50



▶ 3 HEX AND TORX FOLDING SET ASSORTMENT 6455

REF.	€	8 41 4299	g	A mm	B mm	C mm
6455-P3	43,00	618815	6	480	40	105
1,5		2				2,5
3		4				5
6		8				5/64'
3/32'		7/64'				1/8'
9/64'		5/32'				3/16'
7/32'		1/4'				T9
T10		T15				T20
T25		T27				T30
T40						



▶ 9 HEX NICKEL PLATED KEYS KIT 6458

REF.	€	8 41 4299	g	A mm	B mm	C mm
6458-9 N	18,84	507294	6	80	40	70
1,5		2				2,5
3		4				5
6		8				10

SOCKET

- Manufactured in/with Chrome-Vanadium steel.
- Forged in one single piece, unbreakable.
- 3+ steel treatment for a longer tool life: doesn't break, warp or wear away.
- Nickel plated and a matt chrome finish.
- Complies with DIN 3123 and 3124 standards.

Uses:

- For hexagonal torque and adjustment of nuts and bolts.

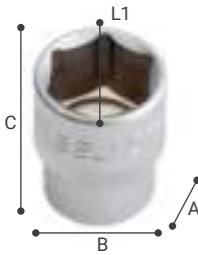

▶ HEXAGONAL SOCKET 1/2" 6520

REF.	€	8 41 4299	g	A mm	B mm	C mm	L1 mm	L2 mm
6520-10	5,05	453010	6	60	20	38	15,5	22
6520-11	5,29	453058	30	60	20	38	16,7	22
6520-12	5,51	453096	30	60	20	38	18	22
6520-13	5,69	453133	30	30	20	38	19,2	22
6520-14	5,92	453171	30	60	20	38	20,5	22
6520-15	6,35	453218	30	60	22	38	22	21
6520-16	6,44	453256	30	60	21	38	22	21
6520-17	6,48	453294	30	70	23	38	24	22
6520-18	6,66	453331	30	80	24	38	25	23
6520-19	6,80	453379	30	80	25	38	26	24
6520-20	7,35	453416	50	90	28	38	28	26
6520-21	7,35	453454	6	80	28	38	28	26
6520-22	7,57	453492	50	100	30	38	30	26
6520-23	7,99	453539	50	120	30	38	32	28
6520-24	8,58	453591	6	120	30	38	32	28
6520-25	8,71	453638	6	140	33	42	34	30
6520-26	8,87	453676	30	170	36	42	36	36
6520-27	9,14	453713	6	160	36	42	36	36
6520-28	9,77	453775	30	200	36	42	38	38
6520-30	10,22	453867	20	210	40	44	40	40
6520-32	10,22	453911	20	230	42	44	42	42

▶ 27 UNITS SET HEXAGONAL SOCKET 1/2" 6592-1/2 H1

REF.	€	8 41 4299	g	A mm	B mm	C mm	L1 mm	L2 mm
6592-1/2 H1	179,04	780611	1	5.230	80	380	305	



▶ UNIVERSAL JOINT 1/2" 6521

REF.	€	8 41 4299	g	A mm	B mm	C mm	L1 mm	L2 mm
6521	25,71	485110	1	166	25	25	135	



▶ SLIDING HANDLE 1/2" 6524

REF.	€	8 41 4299	g	A mm	B mm	C mm	L1 mm	L2 mm
6524	18,16	485233	1	380	45	25	250	



▶ EXTENSION BAR 1/2" 6523

REF.	€	8 41 4299	g	A mm	B mm	C mm	L1 mm	L2 mm
6523-5	11,85	485158	10	230	22	22	185	
6523-10	14,93	485196	1	430	23	23	312	



▶ RATCHET 1/2" 6528

REF.	€	8 41 4299	g	A mm	B mm	C mm	L1 mm	L2 mm
6528	50,57	485431	1	545	40	40	320	

PLIERS

- Manufactured with special Bellota steel.
- Forged head and body: unbreakable.
- Temper and blue steel hardening of the head and induction tempered edges for a longer tool life: doesn't break, warp or wear away.
- Two-materials ergonomic handles with SOFT TOUCH for comfort during work.
- Complies with DIN standards.

Uses:

- For holding, clamping, cutting or handling.
- Universal: Combining holding, clamping and cutting in one single tool. Holding: smooth and refined teeth to hold without marking. Clamping: thick teeth holding rounded parts and pipes. Cutting: semi hard and hard materials to a diameter of 2.5 mm.
- Cutting: for cutting wires.
- Holding and Multi-opening: for holding jobs.

COMBINATION

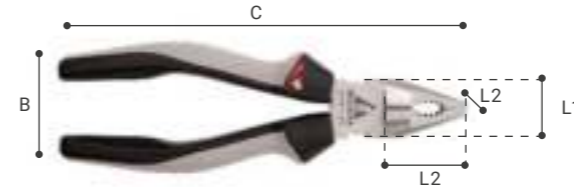

▶ HEAVY-DUTY COMBINATION PLIER 6100

REF.	€	8 41 4299	g	A mm	B mm	C mm	L1 mm	L2 mm	Dmm	
6100-160 BIM	18,94	332797	6	210	35	54	165	25	9	35
6100-180 BIM	20,20	332926	6	270	38	54	185	25,8	9,6	38
6100-200 BIM	23,04	333022	6	300	40	57	210	28,5	9,8	40



▶ COMBINATION PLIER 6102

REF.	€	8 41 4299	g	A mm	B mm	C mm	L1 mm	L2 mm	Dmm	
6102-160 BIM	19,22	333121	6	210	35	54	165	25	9,7	36
6102-180 BIM	21,28	333220	6	280	38	50	185	28	10	37
6102-200 BIM	23,88	333329	6	340	40	50	210	27,6	10,4	42

CUTTING PLIER



▶ SIDE CUTTING PLIER 6110

REF.	€	8 41 4299	g	A mm	B mm	C mm	L1 mm	L2 mm	Dmm
6110-160 BIM	21,39	333527	6	240	23	53	165	21,8	20
6110-180 BIM	23,98	333626	6	290	23	56	185	23,4	20

Induction tempered edges.



▶ HEAVY-DUTY SIDE CUTTING PLIER 6112

REF.	€	8 41 4299	g	A mm	B mm	C mm	L1 mm	L2 mm	Dmm
6112-180 BIM	21,59	333725	6	250	23	53	190	26,8	21
6112-200 BIM	24,41	333909	6	290	23	55	200	26,9	21

Induction tempered edges.



▶ END CUTTING PLIER 6114

REF.	€	8 41 4299	g	A mm	B mm	C mm	L1 mm	L2 mm	Dmm
6114-160 BIM	24,31	333954	6	250	27	52	175	28,5	26

Induction tempered edges.

NOSE PLIER



▶ SEMICIRCULAR STRAIGHT JAW SNIP NOSE PLIER 6120

REF.	€	8 41 4299	g	A mm	B mm	C mm	L1 mm	L2 mm	D mm
6120-160 BIM	21,59	334050	6	110	18	53	164	16,7	2,5 52
6120-200 BIM	24,88	334159	6	190	20,5	53	203	17,5	1,7 76



▶ SEMICIRCULAR CURVED JAW SNIP NOSE PLIER 6122

REF.	€	8 41 4299	g	A mm	B mm	C mm	L1 mm	L2 mm	D mm
6122-200 BIM	25,45	334258	6	190	22	52	200	17,5	2,5 71



▶ FLAT NOSE PLIER 6130

REF.	€	8 41 4299	g	A mm	B mm	C mm	L1 mm	L2 mm	D mm
6130-160 BIM	22,90	334357	6	150	20	54	160	15,8	9,2 33



▶ WIRE STRIPPING PLIERS 6150

REF.	€	8 41 4299	g	A mm	B mm	C mm	L1 mm	L2 mm	D mm
6150-160 BIM	26,21	334555	6	150	20	54	165	20	9

SLIP JOINT PLIER

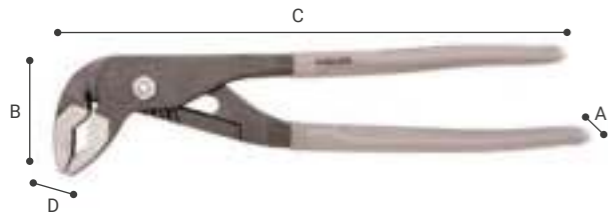

▶ SLIP JOINT PLIER 6160

REF.	€	8 41 4299	g	A mm	B mm	C mm	L1 mm	L2 mm	D mm
6160-250 PVC	18,94	445367	6	250	12	55	250		34

* UNTIL STOCK ENDS



▶ SLIP JOINT PLIER 6162

REF.	€	8 41 4299	g	A mm	B mm	C mm	L1 mm	L2 mm	D mm
6162-250 PVC	27,47	445442	6	310	13	50	245		34

INSULATED PLIERS

- Insulated handles for electrical work with voltage up to 1.000V, with VDE certification and according to DIN standards.
- Manufactured with Bellota Special Steel.
- Head and body forged in one piece, unbreakable.
- Heads with differentiated hardening and tempering treatment on head and cutting edge, to extend the tool's working life: It will not break, warp or wear.

Uses:

- For electrical clamping, fastening, cutting or handling works with voltage up to 1,000V.



▶ INSULATED UNIVERSAL PLIERS 26102

REF.	€	8 41 4299	g	A mm	B mm	C mm	L1 mm	L2 mm	D mm
26102160VDE	21,84	710083	12	210	32	58	170	25	10 35



▶ INSULATED UNIVERSAL PLIERS 26110

REF.	€	8 41 4299	g	A mm	B mm	C mm	L1 mm	L2 mm	D mm
26110160VDE	22,86	710106	6	200	32	58	165	22	20



▶ INSULATED PLIERS FOR HANDLING STRAIGHT HALF-ROUND GRIPS 26120

REF.	€	8 41 4299	g	A mm	B mm	C mm	L1 mm	L2 mm	D mm
26120160VDE	25,40	710144	6	150	28	55	170	17	2 72
26120200VDE	27,44	710168	12	200	30	55	210	18	3 100



▶ INSULATED PLIERS FOR HANDLING CURVED HALF-ROUND GRIPS 26122

REF.	€	8 41 4299	g	A mm	B mm	C mm	L1 mm	L2 mm	D mm
26122200VDE	27,44	710182	12	210	30	58	205	18	1,5 95



▶ INSULATED WIRE STRIPPER 26150

REF.	€	8 41 4299	g	A mm	B mm	C mm	L1 mm	L2 mm	D mm
26150160VDE	28,46	710120	12	200	30	60	170	20	8

ELECTRICIAN'S SHEARS

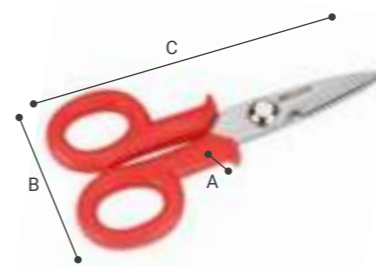

▶ STAINLESS ELECTRICIAN'S SHEARS 26010

REF.	€	8 41 4299	g	A mm	B mm	C mm	L1 mm	L2 mm	D mm
26010	8,10	714814	12	70	16	72	145		



▶ STAINLESS UNIVERSAL SHEARS 26011

REF.	€	8 41 4299	g	A mm	B mm	C mm	L1 mm	L2 mm	D mm
26011	10,13	714838	12	120	18	58	180		

ABRASIVE DISCS

ABRASIVE DISCS

- Complies with the EN-12413 standard.
- High-quality raw materials.
- Mixtures developed to ensure an optimum performance-cutting sensation relation.
- Homogeneity of the discs over time.
- Excellent speed, cutting feeling and finish.

Uses:

- For cutting, and grinding with electric portable or stationary machinery.
- Inox-Metal discs: 1-2 mm thick for tasks on thin metal sheet and up to 3mm profiles and assembly with perfect finishing. 2-3 mm thick for heavy duty cutting and thick profiles jobs.
- Stone discs: 1mm thick for tasks on stone, ceramic, copper profiles, aluminium, brass and plastic. 3 mm thick for heavy duty jobs on concrete, brick, stone and ceramic.
- Three types of grain:
 - A- Corundum: high tenacity grain for professional cutting and grinding.
 - AS- Semi-friable corundum: high friability grain and good tenacity. For stainless steel cutting.
 - C- Silicon carbide: for fragile materials (stone, marble and granite) and soft materials (aluminium, brass).



▶ ABRASIVE CUTTING DISC INOX-METAL EXTRATHIN 50300-50310-50320

REF.	€	8 41 4299	g	A mm	B mm	C mm	mm/inch	E mm
50300-115	1,69	014785	25	30	1	115	115	22,23
50300-125	1,83	014808	25	30	1	125	125	22,23

Flat disc. Dip in centre of disc.



▶ ABRASIVE CUTTING DISC INOX-METAL EXTRATHIN 50300-50310-50320

REF.	€	8 41 4299	g	A mm	B mm	C mm	mm/inch	E mm
50310-115	1,83	014822	25	40	2	115	115	22,23
50310-125	2,09	014839	25	40	1	125	125	22,23

Flat disc. Dip in centre of disc.



▶ ABRASIVE CUTTING DISC INOX-METAL EXTRATHIN 50300-50310-50320

REF.	€	8 41 4299	g	A mm	B mm	C mm	mm/inch	E mm
50320-180	3,29	139617	25	80	3	180	180	22,23
50320-230	3,40	139679	25	180	4	230	230	22,23

Flat disc. Dip in centre of disc.



▶ ABRASIVE CUTTING DISC INOX-METAL THIN 50330

REF.	€	8 41 4299	g	A mm	B mm	C mm	mm/inch	E mm
50330-115	1,88	373806	25	60	7	115	115	22,23
50330-125	2,06	374001	25	70	6	125	125	22,23
50330-180	2,60	374179	25	160	10	180	180	22,23
50330-230	3,80	374292	25	220	5	230	230	22,23

Dip in centre of disc.



▶ ABRASIVE CUTTING DISC INOX-METAL 50301

REF.	€	8 41 4299	g	A mm	B mm	C mm	mm/inch	E mm
50301-115	1,88	600711	25	70	7	115	115	22,23
50301-125	2,06	600728	25	90	6	125	125	22,23
50301-180	2,60	600735	25	180	6	180	180	22,23
50301-230	3,70	600742	25	270	7	230	230	22,23

Dip in centre of disc.



▶ ABRASIVE CUTTING DISC METAL STATIONARY MACHINE 50431-50441-50321

REF.	€	8 41 4299	g	A mm	B mm	C mm	mm/inch	E mm
50441-300	10,05	941005	25	550	4	300	300	25,4

Flat disc.



▶ ABRASIVE CUTTING DISC STONE EXTRATHIN 50322

REF.	€	8 41 4299	g	A mm	B mm	C mm	mm/inch	E mm
50322-115	2,10	606768	25	20	1	115	115	22,23

Flat disc.



▶ ABRASIVE CUTTING DISC INOX-METAL THIN 50420

REF.	€	8 41 4299	g	A mm	B mm	C mm	mm/inch	E mm
50420-115	2,53	388923	25	50	7	115	115	22,23
50420-230	5,06	389265	25	220	5	230	230	22,23

Dip in centre of disc.



▶ ABRASIVE CUTTING DISC METAL STATIONARY MACHINE 50431-50441-50321

REF.	€	8 41 4299	g	A mm	B mm	C mm	mm/inch	E mm
50431-300	10,05	940961	25	560	4	300	300	22,23

Flat disc.



▶ ABRASIVE CUTTING DISC METAL STATIONARY MACHINE 50431-50441-50321

REF.	€	8 41 4299	g	A mm	B mm	C mm	mm/inch	E mm
50321-350	16,07	600926	25	770	4	350	350	25,4

Flat disc.



▶ ABRASIVE CUTTING DISC STONE 50302

REF.	€	8 41 4299	g	A mm	B mm	C mm	mm/inch	E mm
50302-115	2,09	600759	25	60	9	115	115	22,23
50302-125	2,21	600766	25	70	8	125	125	22,23
50302-230	4,25	600780	25	230	5	230	230	22,23

Dip in centre of disc.



▶ ABRASIVE CUTTING DISC INOX-METAL 50421

REF.	€	8 41 4299	g	A mm	B mm	C mm	mm/inch	E mm
50421-115	2,53	924596	25	70	10	115	115	22,23
50421-125	2,68	924633	25	80	10	125	125	22,23
50421-180	3,49	924671	25	180	7	180	180	22,23
50421-230	5,06	924718	25	290	5	230	230	22,23

Dip in centre of disc.



▶ ABRASIVE CUTTING DISC INOX-METAL EXTRATHIN 50400

REF.	€	g	A mm	B mm	C mm	mm/inch	E mm
50400-115	1,09	556506	25	20	2	115/115	22,23 1 AS 60 INOX - BF
50400-125	1,25	586848	25	30	2	125/125	22,23 1 AS 60 INOX - BF

Flat disc.



▶ ABRASIVE CUTTING DISC INOX-METAL 50480

REF.	€	g	A mm	B mm	C mm	mm/inch	E mm
50480-115	1,02	446999	25	70	6	115/115	22,23 3 A 24 R - BF
50480-125	1,12	512656	25	80	7	125/125	22,23 3 A 24 R - BF
50480-230	2,35	447057	25	280	7	230/230	22,23 3 A 24 R - BF

Dip in centre of disc.



▶ ABRASIVE CUTTING DISC STONE 50482

REF.	€	g	A mm	B mm	C mm	mm/inch	E mm
50482-115	1,17	447118	25	60	6	115/115	22,23 3 C 24 R - BF
50482-230	2,37	447163	25	230	6	230/230	22,23 3 C 24 R - BF

Dip in centre of disc.

ABRASIVE GRINDING DISCS



▶ ABRASIVE GRINDING DISC INOX-METAL / HARD 50351

REF.	€	g	A mm	B mm	C mm	mm/inch	E mm
50351-115	2,70	124422	10	160	10	115/115	22,23 7 A 30 T - BF
50351-125	3,07	124552	10	190	15	125/125	22,23 7 A 30 T - BF
50351-180	5,22	124828	10	410	10	180/180	22,23 7 A 30 T - BF
50351-230	7,00	124958	10	620	9	230/230	22,23 7 A 30 T - BF

Dip in centre of disc.



▶ ABRASIVE GRINDING DISC INOX-METAL / SOFT 50361

REF.	€	g	A mm	B mm	C mm	mm/inch	E mm
50361-115	2,70	125221	10	160	10	115/115	22,23 7 AS 30 Q - BF
50361-125	3,07	125337	10	200	12	125/125	22,23 7 AS 30 Q - BF
50361-180	5,22	125429	10	410	10	180/180	22,23 7 AS 30 Q - BF
50361-230	7,00	125535	10	650	10	230/230	22,23 7 AS 30 Q - BF

Dip in centre of disc.



▶ ABRASIVE GRINDING DISC STONE 50352

REF.	€	g	A mm	B mm	C mm	mm/inch	E mm
50352-115	3,01	124576	10	140	12	115/115	22,23 7 C 30 S - BF

Dip in centre of disc.

STRIP DISCS

POLYAMIDE BASE

- Adapted fat base for fat surface finishes.
- Does not stain or scratch the worked surface.
- Improved disc use as the nylon base can be worn during the work.
- Cotton support fabrics that offer a very good finishing sensation and avoid burn marks on the material, making the discs to be very adequate for working with stainless steel.
- Longer useful life +15% higher filing capacity than fiberglassbased discs.

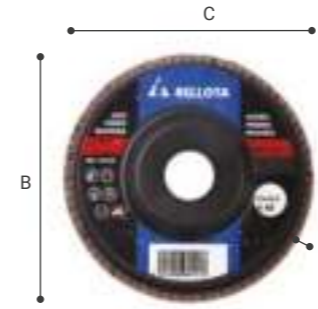

▶ STRIP DISC GRINDING METAL. GRAIN A 50501

REF.	€	g	A mm	B mm	C mm	mm/inch
50501-40	8,17	601152	10	100	20	108/108 22,2 A 40
50501-60	8,17	601169	10	90	19	108/108 22,2 A 60
50501-80	8,17	601176	10	90	18	108/108 22,2 A 80
50501-120	8,17	601220	10	90	17	108/108 22,2 A 120

Dip in centre of disc.



▶ STRIP DISC GRINDING INOX-METAL. GRAIN AZ 50502

REF.	€	g	A mm	B mm	C mm	mm/inch
50502-40	9,13	601190	10	100	20	108/108 22,2 AZ 40
50502-60	9,13	601206	10	100	19	108/108 22,2 AZ 60
50502-80	9,13	601213	10	90	18	108/108 22,2 AZ 80
50502-120	9,13	601237	10	80	17	108/108 22,2 AZ 120

Dip in centre of disc.



▶ STRIP DISC GRINDING STONE. GRAIN SIC 50503

REF.	€	g	A mm	B mm	C mm	mm/inch
50503-40	8,82	601244	10	90	20	108/108 22,2 SIC 40
50503-60	8,82	601251	10	90	19	108/108 22,2 SIC 60
50503-80	8,82	601268	10	80	18	108/108 22,2 SIC 80
50503-120	8,82	601275	10	80	17	108/108 22,2 SIC 120

Dip in centre of disc.

FIBERGLASS BASE

- Slanted Face for edge finishing works.
- Does not stain or scratch the worked surface.
- Polyester support fabrics that provide great performance.



► STRIP DISC GRINDING METAL. GRAIN A 50511-50551-50611

REF.	€	8 41 4299	g	A mm	B mm	C mm	ø mm/inch
50511-40	5,72	941302	10	80	10	108	22,2 A 40
50511-60	5,72	941333	10	70	10	108	22,2 A 60
50511-80	5,72	941364	10	70	10	108	22,2 A 80
50511-120	5,72	941395	10	70	11	108	22,2 A 120

Dip in centre of disc.



► STRIP DISC GRINDING METAL. GRAIN A 50511-50551-50611

REF.	€	8 41 4299	g	A mm	B mm	C mm	ø mm/inch
50551-60	6,47	300314	10	100	12	116	22,2 A 60

Dip in centre of disc.

* 50551-60 UNTIL END OF STOCK.



► STRIP DISC GRINDING METAL. GRAIN A 50511-50551-50611

REF.	€	8 41 4299	g	A mm	B mm	C mm	ø mm/inch
50611-40	11,22	941661	10	200	11	170	22,2 A 40
50611-60	11,22	941692	10	210	10	170	22,2 A 60
50611-80	11,22	941722	10	210	10	170	22,2 A 80

Dip in centre of disc.

*50611-60, 50611-80 UNTIL END OF STOCK.



► STRIP DISC GRINDING INOX-METAL. GRAIN AZ 50512-50552-50612

REF.	€	8 41 4299	g	A mm	B mm	C mm	ø mm/inch
50512-40	6,47	941425	10	80	11	108	22,2 AZ 40
50512-60	6,47	941456	10	70	12	108	22,2 AZ 60
50512-80	6,47	941487	10	70	1	108	22,2 AZ 80
50512-120	6,47	941517	10	70	10	108	22,2 AZ 120

Dip in centre of disc.



► STRIP DISC GRINDING STONE. GRAIN SIC 50513

REF.	€	8 41 4299	g	A mm	B mm	C mm	ø mm/inch
50513-40	6,25	941548	10	70	14	108	22,2 SIC 40
50513-60	6,25	941579	10	70	13	108	22,2 SIC 60
50513-80	6,25	941609	10	70	12	108	22,2 SIC 80
50513-120	6,25	941630	10	70	10	108	22,2 SIC 120

Dip in centre of disc.

BRUSHES

- High-quality materials for excellent performance.
- Wires with high wear resistance.
- Optimum material and wires combination to ensure required finishing accuracy.

Uses:

- For brushing, cleaning jobs, removing paint, varnish, flakes, rust and small burr.
- Four wire materials:
 - Stainless steel: for non contamination cleaning, rust stains, soot on stainless steel, aluminium or special alloys.
 - Brass coated steel: for working on copper, plastic, lead, aluminium, glass and steel.
 - Brass: for non-ferrous steel and spark-free tasks.
 - Nylon: for difficult to reach areas. Coarse grain (Red) rough finishing. Fine grain (Blue) fine finishing.
- Three wire types:
 - Braided wires: for maximum performance in heavy-duty tasks and tasks requiring speed and firmness.
 - Corrugated wire: for continuous brushing tasks and slight burrs removal. Fine finishing.
 - Straight wire for any type of Frushing. Medium finishing.

HANDHELD BRUSHES

- For working with grinders on fix benches.

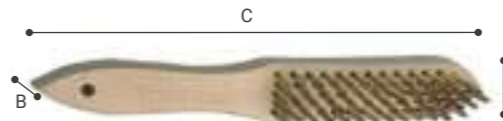

► BRUSH BRASS COATED STEEL STRAIGHT WIRE 50801

REF.	€	8 41 4299	g	A mm	B mm	C mm	H
50801-3	1,52	372380	24	100	45	27	292 3
50801-4	1,75	372427	24	130	47	33	295 4
50801-5	2,34	372465	24	130	46	38	295 5

Brass coated steel. ø 0.3 straight wire.



► BRUSH STAINLESS STEEL STRAIGHT WIRE 50802

REF.	€	8 41 4299	g	A mm	B mm	C mm	H
50802-3	5,57	372502	24	100	45	28	295 3
50802-4	6,72	372540	24	100	45	32	290 4
50802-5	8,02	372588	24	120	35	40	300 5

Stainless steel. ø 0.3 straight wire.



► BRUSH BRASS CORRUGATED WIRE 50803

REF.	€	8 41 4299	g	A mm	B mm	C mm	H
50803-3	3,30	372625	24	80	45	27	295 3
50803-4	4,40	372663	24	110	45	30	295 4
50803-5	5,88	372700	24	140	45	36	291 5

Brass. ø 0.3 corrugated wire.



► BRUSH WITHOUT HANDLE BRASS COATED STEEL STRAIGHT WIRE 50804

REF.	€	8 41 4299	g	A mm	B mm	C mm	H
50804-5	2,66	372748	24	130	47	36	290 5

Without handle, for heavy duty works.



► NARROW BRUSH BRASS COATED STEEL STRAIGHT WIRE 50806-A

REF.	€	8 41 4299	g	A mm	B mm	C mm	H
50806-A	2,08	372823	24	110	20	65	260

Brass coated steel 0.3 straight wire. Very narrow, to reach difficult places.



► NARROW BRUSH STAINLESS STEEL CORRUGATED WIRE 50806-I

REF.	€	8 41 4299	g	A mm	B mm	C mm	H
50806-I	6,41	372861	24	110	20	65	255

Stainless steel 0.3 corrugated wire. Very narrow, to reach difficult places.



► NARROW BRUSH BRASS CORRUGATED WIRE 50806-L

REF.	€	8 41 4299	g	A mm	B mm	C mm	H
50806-L	6,10	372908	24	110	20	65	250

Brass coated steel 0.3 straight wire. Very narrow, to reach difficult places.



► SPARK PLUG CLEANER BRASS CORRUGATED WIRE 50805-L

REF.	€	8 41 4299	g	A mm	B mm	C mm	H
50805-L	4,03	633832	24	40	20	72	172

0,15 mm. Brass Corrugated wire.

DIY BRUSHES

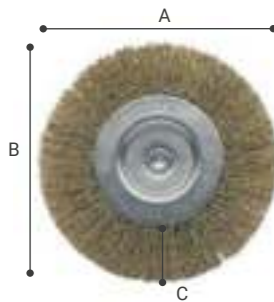

► WHEEL BRUSH BRASS COATED STEEL CORRUGATED WIRE 50807

REF.	€	8 41 4299	g	A mm	B mm	C mm	L1 mm	L2 mm	RPM max
50807-50	1,86	373066	24	40	50	50	35	10	8 4500
50807-60	1,86	373103	24	50	60	60	37	14	8 4500
50807-75	2,29	373141	24	70	75	75	40	16	10 4500
50807-100	3,51	373189	12	110	100	100	40	23	10 4500

Corrugated wire. 6 mm bolt



► WHEEL BRUSH BRASS STAINLESS STEEL CORRUGATED WIRE 50807-50 I

REF.	€	8 41 4299	g	A mm	B mm	C mm	L1 mm	L2 mm	RPM max
50807-50 I	4,51	686784	24	40	50	50	35	10	8 4500
50807-75 I	5,94	686869	24	70	75	75	40	16	10 4500



► CUP BRUSH BRASS COATED STEEL CORRUGATED WIRE 50808

REF.	€	8 41 4299	g	A mm	B mm	C mm	L1 mm	L2 mm	RPM max
50808-50	2,39	373226	24	70	55	55	64	18	50 4500
50808-75	3,46	373264	24	120	70	70	25	75	4500
50808-80	4,26	936193	12	200	75	75	80	25	75 4500

Corrugated wire. 6 mm bolt



► CUP BRUSH STAINLESS STEEL CORRUGATED WIRE 50808-50 I

REF.	€	8 41 4299	g	A mm	B mm	C mm	L1 mm	L2 mm	RPM max
50808-50 I	8,43	633733	24	70	55	55	64	18	50 4500

Corrugated wire. 6 mm bolt



► END BRUSH BRASS COATED STEEL CORRUGATED WIRE 50809-25

REF.	€	8 41 4299	g	A mm	B mm	C mm	L1 mm	L2 mm	RPM max
50809-25	3,26	373301	24	60	30	30	75	31	25 4500

Corrugated wire. 6 mm bolt



► DIY BRUSHES DISPLAY 50850

REF.	€	8 41 4299	g	A mm	B mm	C mm	L1 mm	L2 mm	RPM max
50850	100,16	904031	1	3.093	358	220	122		4500

CIRCULAR INDUSTRIAL BRUSHES

• For working with grinders on fix benches.



► WHEEL BRUSH BRASS COATED STEEL CORRUGATED WIRE 50810

REF.	€	8 41 4299	g	A mm	B mm	C mm	L1 mm	L2 mm	RPM max
50810-10016	11,87	373387	6	300	100	100	20	22	16 8000
50810-10020	16,66	373424	6	250	100	100	25	22	20 8000
50810-12518	12,80	373462	6	300	125	125	20	30	18 8000
50810-15018	16,02	373547	6	560	150	150	30	27,5	18 6000
50810-20020	21,27	373707	6	850	200	200	30	42,5	20 4500
50810-20025	29,99	373745	6	740	200	200	30	42,5	25 4500

0.30 mm diameter crimped wire.



► WHEEL BRUSH STAINLESS STEEL CORRUGATED WIRE 50810 I

REF.	€	8 41 4299	g	A mm	B mm	C mm	L1 mm	L2 mm	RPM max
50810-15025 I	37,17	633795	12	500	150	150	25	27,5	15 6000

0.30 mm diameter crimped wire.



► WHEEL BRUSH HARDENED STEEL BRAIDED WIRE 50811

REF.	€	8 41 4299	g	A mm	B mm	C mm	L1 mm	L2 mm	RPM max
50811-100	20,80	373783	6	180	100	100	15	20,5	12 12500
50811-115	21,27	373936	6	220	115	115	20	22	12 12500
50811-150	25,77	374124	6	480	150	150	20	36,5	13 9000
50811-175	29,12	374162	6	660	175	175	20	42,5	13 9000

INDUSTRIAL CUP BRUSHES

• For working on large metal surfaces using angle grinders and mini grinders in areas difficult to reach.



► CUP BRUSH BRASS COATED STEEL CORRUGATED WIRE 50812

REF.	€	8 41 4299	g	A mm	B mm	C mm	L1 mm	L2 mm	RPM max
50812-80	16,43	374209	6	240	85	85	60	28	80 8500
50812-100	20,12	374247	6	460	105	105	70	30	100 8500
50812-125	29,52	374285	6	490	120	120	80	35	125 8500

0.30 mm diameter crimped wire.



► CUP BRUSH STAINLESS STEEL CORRUGATED WIRE 50812 I

REF.	€	8 41 4299	g	A mm	B mm	C mm	L1 mm	L2 mm	RPM max
50812-80 I	32,17	633771	12	230	85	85	60	28	80 8500

0.30 mm diameter crimped wire.



► CUP BRUSH HARDENED STEEL BRAIDED WIRE 50813

REF.	€	8 41 4299	g	A mm	B mm	C mm	L1 mm	L2 mm	RPM max
50813-80	23,41	374322	6	670	85	85	75	28	85 8500
50813-100	24,88	374360	6	1.000	105	105	80	21	100 8500
50813-120	31,39	374407	6	1.180	120	120	78	23	120 8500



► CUP BRUSH BRASS COATED STEEL CORRUGATED WIRE 50814

REF.	€	8 41 4299	g	A mm	B mm	C mm	L1 mm	L2 mm	RPM max
50814-75	15,48	374445	12	220	75	75	58	28	75 12500

To use in mini-grinders.



► CUP BRUSH BRASS COATED STEEL CORRUGATED WIRE 50814

REF.	€	8 41 4299	g	A mm	B mm	C mm	L1 mm	L2 mm	RPM max
50814-65	14,91	374483	12	280	73	73	50	21,5	12500

To use in mini-grinders.

CONICAL INDUSTRIAL BRUSHES

• To use with mini grinders.



► CONIC BRUSH BRASS COATED STEEL CORRUGATED WIRE 50815

REF.	€	8 41 4299	g	A mm	B mm	C mm	L1 mm	L2 mm	RPM max
50815-1001	16,43	374520	12	180	100	100	30	20	12500
50815-1002	30,62	374568	12	260	100	100	40	20	12500

Corrugated wire.



► CONIC BRUSH BRASS COATED STEEL CORRUGATED WIRE 50816

REF.	€	8 41 4299	g	A mm	B mm	C mm	L1 mm	L2 mm	RPM max
50816-1001	34,40	374605	12	180	100	100	30	20	12500
50816-1002	51,79	374643	12	260	100	100	40	20	12500

Corrugated wire.



► CONIC BRUSH BRASS COATED STEEL CORRUGATED WIRE 50817

REF.	€	8 41 4299	g	A mm	B mm	C mm	L1 mm	L2 mm	RPM max
50817-1001	17,27	374681	12	210	100	100	30	20	12500
50817-1151	20,12	374728	12	270	110	110	35	20	12500



► CONIC BRUSH BRASS COATED STEEL CORRUGATED WIRE 50817-I

REF.	€	8 41 4299	g	A mm	B mm	C mm	L1 mm	L2 mm	RPM max
50817-1001 I	37,78	633818	12	210	100	100	33	20	12500

Corrugated wire.



► END BRUSH COATED STEEL CORRUGATED WIRE 50818

REF.	€	8 41 4299	g	A mm	B mm	C mm	L1 mm	L2 mm	RPM max
50818-25	5,94	686708	24	60	25	25	76	30	20000



► END BRUSH STAINLESS STEEL CORRUGATED WIRE 50818-I

REF.	€	8 41 4299	g	A mm	B mm	C mm	L1 mm	L2 mm	RPM max
50818-25I	9,84	633757	24	60	25	25	76	30	20000

Corrugated wire. 6 mm bolt.

INDUSTRIAL NYLON BRUSHES

- Manufactured with highly flexible nylon filaments preventing the breakage with carbon silicate aFrasiZe grains.
- Two types of grain:
 - Thick red, 80 grain.
 - Thin blue, 180 grain.
- With 6 mm bolt to fit into standard drills.



► NYLON WHEEL BRUSH 50825

REF.	€	8 41 4299	g	A mm	B mm	C mm	L1 mm	L2 mm	RPM max
50825-100B	8,48	375329	12	90	100	100	40	23	4500
50825-75B	7,00	375244	24	70	75	75	40	16	4500

6 mm bolt.



► NYLON WHEEL BRUSH 50825

REF.	€	8 41 4299	g	A mm	B mm	C mm	L1 mm	L2 mm	RPM max
50825-75F	7,33	375602	24	70	75	75	40	16	4500
50825-100F	8,82	375282	12	90	100	100	40	23	4500

6 mm bolt.



► NYLON CUP BRUSH 50826-75F

REF.	€	8 41 4299	g	A mm	B mm	C mm	L1 mm	L2 mm	RPM max	
50826-75B	7,33	375480	24	100	75	75	72	25	75	4500
50826-50B	6,85	375404	24	50	50	50	65	18	50	4500

6 mm bolt.



► NYLON CUP BRUSH 50826-75F

REF.	€	8 41 4299	g	A mm	B mm	C mm	L1 mm	L2 mm	RPM max	
50826-50F	7,00	375367	24	50	50	50	65	18	50	4500
50826-75F	7,56	375442	24	100	75	75	73	25	75	4500

6 mm bolt.



► NYLON END BRUSH 50827-25B

REF.	€	8 41 4299	g	A mm	B mm	C mm	L1 mm	L2 mm	RPM max	
50827-25B	5,61	375565	24	40	25	25	70	25	25	4500

6 mm bolt.



► NYLON END BRUSH 50827-25B

REF.	€	8 41 4299	g	A mm	B mm	C mm	L1 mm	L2 mm	RPM max	
50827-25F	5,84	375527	24	40	25	25	70	25	25	4500

6 mm bolt.



► NYLON FLAP BRUSH 50829

REF.	€	8 41 4299	g	A mm	B mm	C mm	L1 mm	L2 mm	RPM max	
50829-100B	9,04	961034	12	70	100	100	55	25	100	3500



► NYLON FLAP BRUSH 50829

REF.	€	8 41 4299	g	A mm	B mm	C mm	L1 mm	L2 mm	RPM max	
50829-100F	9,04	961072	12	70	100	100	50	25	100	3500

CLAMPING

BENCH VICES

- Made with special Bellota steel.
- Heat treated milled vices for better grip.
- Broad anvil providing a larger working area.
- Support on a square guide.
- High strength.

Uses:

- For holding, gripping and mounting different parts or profiles.

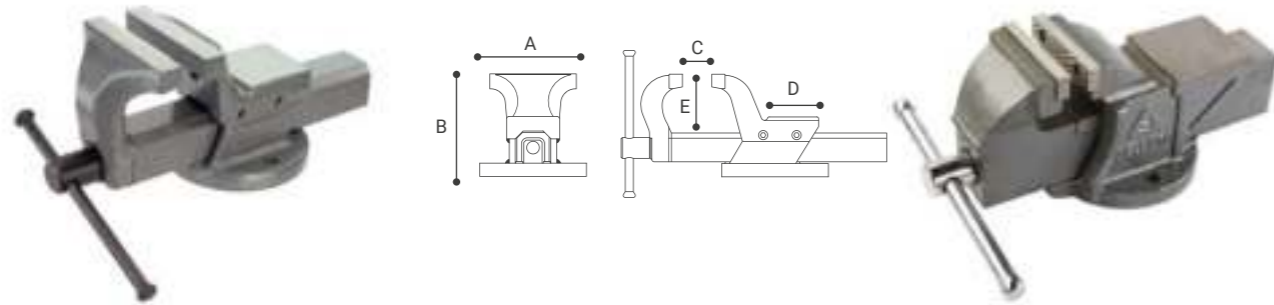

▶ FORGED BENCH VICE 6700

REF.	€	Barcode	g	A mm	B mm	C mm	L mm
6700-100	237,03	026313	1	6.580	122	300	125
6700-125	335,75	026337	1	9.790	140	355	150
6700-150	433,18	019872	1	16.390	162	456	200
6700-175	579,03	019858	1	25.670	200	515	220

▶ CAST BENCH VICE 6710

REF.	€	Barcode	g	A mm	B mm	C mm	L mm
6710-80	76,14	365375	1	5.220	109	266	175
6710-100	107,49	353419	1	6.080	110	275	177
6710-125	139,61	353457	1	11.350	135	340	190
6710-150	181,26	353488	1	14.750	159	395	220

C CLAMPS

- Nodular cast steel heads.
- Calibrated steel toothed wheel.
- Anti-slip brake on the moving head.
- Flat surface mounting.

Uses:

- For holding, gripping and mounting different parts and profiles.



▶ WOOD HANDLE C CLAMP 51200

REF.	€	Barcode	g	A mm	B mm	C mm	L1 mm	L2 mm
51200-15	13,02	215236	10	530	25	90	220	60
51200-20	13,79	215298	10	570	25	100	270	60
51200-25	14,90	215366	10	610	25	95	320	60
51200-30	15,66	215434	10	680	25	106	370	60

Wood Handle.



▶ IRON CROSS HANDLE C CLAMP 51201

REF.	€	Barcode	g	A mm	B mm	C mm	L1 mm	L2 mm
51201-15	13,02	215564	12	500	20	95	220	60
51201-20	13,79	215632	12	550	20	95	270	60
51201-25	14,90	215694	12	590	20	95	320	60
51201-30	15,66	215755	12	650	20	95	380	60

T Handle.



▶ PROFESSIONAL C CLAMP 51210

REF.	€	Barcode	g	A mm	B mm	C mm	L1 mm	L2 mm
51210-25	24,03	215960	12	1.410	140	25	350	90
51210-30	25,52	216035	14	1.500	140	28	400	90
51210-40	28,78	216097	14	1.680	140	30	500	90
51210-50	31,68	216165	12	1.870	140	28	600	90
51210-60	34,35	216233	12	2.050	140	30	700	90
51210-80	39,24	216295	10	2.400	140	28	900	90

Wood Handle.



▶ PROFESSIONAL C CLAMP 51215

REF.	€	Barcode	g	A mm	B mm	C mm	L1 mm	L2 mm
51215-30	25,87	216561	14	1.760	30	142	400	90
51215-40	29,23	216639	14	1.920	28	145	502	90
51215-50	31,82	216691	12	2.090	26	145	602	90
51215-60	34,80	216752	12	2.240	140	25	700	90
51215-80	39,41	216813	10	2.610	140	23	900	90

T Handle.



▶ EXTRA PROFESSIONAL C CLAMP 51225

REF.	€	Barcode	g	A mm	B mm	C mm	L1 mm	L2 mm
51225-35	29,56	217490	12	2.320	180	34	470	120
51225-40	31,00	217568	12	2.490	185	34	523	120
51225-50	33,47	217636	10	2.630	185	34	610	120
51225-60	36,05	217698	8	2.840	180	34	720	120
51225-80	41,24	217766	8	3.260	185	34	915	120
51225-100	46,38	217834	6	3.720	180	34	1.120	120

T Handle.

FILES AND RASPS

- Manufactured with special Bellota steel.
- Forged in one single piece, unbreakable.
- 3+ steel treatment for a longer tool life: doesn't break, warp or wear away.
- Each file has the perfect hardness, to get the maximum durability, depending on the work to be done.
- Uniform teeth for a uniform result.
- Option to put a dual material ergonomic handle with SOFT TOUCH for comfort during work.

MECHANICAL FILES

- For regrinding, filing, rasping and finishing jobs in mechanical workshops and general industry.

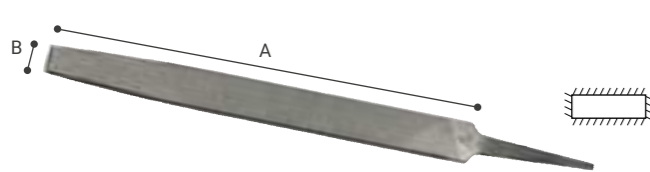

▶ MECHANICAL FLAT POINTED FILE 4001

REF.	€	8 41 4299	g	A mm	B mm	M
4001-4 BAS.	7,05	400106	12	25	100	7,9-11,2 4089-2/4090-2/4093-B4
4001-4 ENT.	7,35	400304	12	25	100	7,9-11,2 4089-2/4090-2/4093-B4
4001-4 FIN.	8,10	400502	12	25	100	7,9-11,2 4089-2/4090-2/4093-B4
4001-6 BAS.	8,07	400700	12	70	150	10,5-15,1 4089-4/4090-3/4093-B3
4001-6 ENT.	8,45	400908	12	70	150	10,5-15,1 4089-4/4090-3/4093-B3
4001-6 FIN.	9,38	401301	12	70	150	10,5-15,1 4089-4/4090-3/4093-B3
4001-8 BAS.	10,43	401509	12	150	200	13,3-19,2 4089-7/4090-4/4093-A4
4001-8 ENT.	10,86	401707	12	150	200	13,3-19,2 4089-7/4090-4/4093-A4
4001-8 FIN.	11,93	402100	12	150	200	13,3-19,2 4089-7/4090-4/4093-A4
4001-10 BAS.	14,65	402308	12	271	250	16-24,4 4090-5/4093-A2
4001-10 ENT.	15,08	402506	12	271	250	16-24,4 4090-5/4093-A2
4001-10 FIN.	16,46	402704	12	271	250	16-24,4 4090-5/4093-A2
4001-12 BAS.	19,62	402902	6	463	300	19-29 4090-6/4093-A2
4001-12 ENT.	20,43	403107	6	463	300	19-29 4090-6/4093-A2
4001-12 FIN.	21,90	403305	6	463	300	19-29 4090-6/4093-A2
4001-14 BAS.	23,77	403503	6	720	350	22,5-34 4090-6/4093-A1
4001-14 ENT.	25,04	403701	6	720	350	22,5-34 4090-6/4093-A1
4001-14 FIN.	26,56	403909	6	720	350	22,5-34 4090-6/4093-A1

Flat file. Two sides.



▶ BIMATERIAL HANDLE MECHANICAL FLAT POINTED FILE 4001

REF.	€	8 41 4299	g	A mm	B mm	M
4001-4 BAS. MB	9,44	097818	6	63	100	7,9-11,2 4093-B4
4001-4 ENT. MB	9,61	093650	6	63	100	7,9-11,2 4093-B4
4001-6 BAS. MB	10,23	093865	6	125	150	10,5-15,1 4093-B3
4001-6 ENT. MB	10,87	093759	6	125	150	10,5-15,1 4093-B3
4001-6 FIN. MB	12,26	098051	6	125	150	10,5-15,1 4093-B3
4001-8 BAS. MB	11,98	098242	6	220	200	13,3-19,2 4093-A4
4001-8 ENT. MB	12,99	098549	6	220	200	13,3-19,2 4093-A4
4001-8 FIN. MB	13,69	098679	6	220	200	13,3-19,2 4093-A4
4001-10 BAS. MB	16,88	131666	6	353	250	16-24,4 4093-A2
4001-10 ENT. MB	16,61	099171	6	353	250	16-24,4 4093-A2
4001-10 FIN. MB	18,17	099294	6	353	250	16-24,4 4093-A2

Flat file. Two sides.



▶ MECHANICAL FLAT PARALLEL FILE 4002

REF.	€	8 41 4299	g	A mm	B mm	M
4002-4 BAS.	7,27	404203	12	27	100	11,2 4089-2/4090-2/4093-B4
4002-4 ENT.	7,35	404401	12	27	100	11,2 4089-2/4090-2/4093-B4
4002-4 FIN.	7,89	404609	12	27	100	11,2 4089-2/4090-2/4093-B4
4002-6 BAS.	8,32	404807	12	75	150	15,1 4089-4/4090-3/4093-B3
4002-6 ENT.	8,45	405002	12	75	150	15,1 4089-4/4090-3/4093-B3
4002-6 FIN.	9,38	405200	12	75	150	15,1 4089-4/4090-3/4093-B3
4002-8 BAS.	10,75	405606	12	156	200	19,2 4089-7/4090-4/4093-A4
4002-8 ENT.	10,86	405804	12	156	200	19,2 4089-7/4090-4/4093-A4
4002-8 FIN.	11,93	406009	12	156	200	19,2 4089-7/4090-4/4093-A4
4002-10 BAS.	14,65	406207	12	279	250	24,4 4090-5/4093-A2
4002-10 ENT.	15,52	406405	12	279	250	24,4 4090-5/4093-A2
4002-10 FIN.	16,46	406603	12	279	250	24,4 4090-5/4093-A2
4002-12 BAS.	19,62	406801	6	476	300	29 4090-6/4093-A2
4002-12 ENT.	20,43	407006	6	476	300	29 4090-6/4093-A2
4002-12 FIN.	21,90	407204	6	476	300	29 4090-6/4093-A2
4002-14 BAS.	23,77	407402	6	750	350	34 4090-6/4093-A1
4002-14 ENT.	25,04	407600	6	750	350	34 4090-6/4093-A1

Flat file. Three sides.



▶ BIMATERIAL HANDLE MECHANICAL FLAT PARALLEL FILE 4002

REF.	€	8 41 4299	g	A mm	B mm	M
4002-4 BAS. MB	9,61	109986	6	67	100	11,2 4093-B4
4002-4 ENT. MB	9,68	110043	6	67	100	11,2 4093-B4
4002-6 BAS. MB	10,40	111064	6	130	150	15,1 4093-B3
4002-6 ENT. MB	10,23	120585	6	130	150	15,1 4093-B3
4002-6 FIN. MB	11,18	131741	6	130	150	15,1 4093-B3
4002-8 BAS. MB	12,33	131819	6	223	200	19,2 4093-A4
4002-8 ENT. MB	12,75	131871	6	223	200	19,2 4093-A4
4002-8 FIN. MB	13,69	131932	6	223	200	19,2 4093-A4
4002-10 BAS. MB	16,54	109900	6	292	250	24,4 4093-A2
4002-10 ENT. MB	17,08	109962	6	292	250	24,4 4093-A2
4002-10 FIN. MB	18,17	132045	6	292	250	24,4 4093-A2

Flat file. Three sides.



▶ MECHANICAL HALF ROUNDED FILE 4003

REF.	€	8 41 4299	g	A mm	B mm	M
4003-4 BAS.	10,99	408102	12	18	100	8,9-10,6 4089-2/4090-2/4093-B4
4003-4 ENT.	11,30	408300	12	18	100	8,9-10,6 4089-2/4090-2/4093-B4
4003-4 FIN.	12,14	408508	12	18	100	8,9-10,6 4089-2/4090-2/4093-B4
4003-6 BAS.	11,78	408706	12	53	150	12,7-15 4089-4/4090-3/4093-B3
4003-6 ENT.	12,32	408904	12	53	150	12,7-15 4089-4/4090-3/4093-B3
4003-6 FIN.	13,23	409307	12	53	150	12,7-15 4089-4/4090-3/4093-B3
4003-8 BAS.	13,72	409505	12	123	200	14,8-19,8 4089-7/4090-4/4093-A4
4003-8 ENT.	14,66	409703	12	123	200	14,8-19,8 4089-7/4090-4/4093-A4
4003-8 FIN.	16,09	410105	12	123	200	14,8-19,8 4089-7/4090-4/4093-A4
4003-10 BAS.	19,25	410303	12	230	250	19-24 4090-5/4093-A3
4003-10 ENT.	20,01	410501	12	230	250	19-24 4090-5/4093-A3
4003-10 FIN.	21,82	410709	12	230	250	19-24 4090-5/4093-A3
4003-12 BAS.	25,73	410907	6	385	300	19,5-28,5 4090-6/4093-A2
4003-12 ENT.	26,69	411102	6	385	300	19,5-28,5 4090-6/4093-A2
4003-12 FIN.	28,81	411300	6	385	300	19,5-28,5 4090-6/4093-A2
4003-14 BAS.	31,60	411508	6	586	350	23-33,2 4090-6/4093-A1
4003-14 ENT.	33,31	411706	6	586	350	23-33,2 4090-6/4093-A1

Half-round file.



▶ BIMATERIAL HANDLE MECHANICAL HALF ROUNDED FILE 4003

REF.	€	8 41 4299	g	A mm	B mm	M
4003-4 BAS. MB	13,00	132465	6	57	100	8,9-10,6 4093-B4
4003-4 ENT. MB	13,08	132526	6	57	100	8,9-10,6 4093-B4
4003-4 FIN. MB	13,69	132588	6	57	100	8,9-10,6 4093-B4
4003-6 BAS. MB	13,45	132656	6	103	150	12,7-15 4093-B3
4003-6 ENT. MB	14,82	132724	6	103	150	12,7-15 4093-B3
4003-6 FIN. MB	15,57	132786	6	103	150	12,7-15 4093-B3
4003-8 BAS. MB	15,88	132847	6	173	200	14,8-19,8 4093-A4
4003-8 ENT. MB	17,85	132915	6	173	200	14,8-19,8 4093-A4
4003-8 FIN. MB	18,89	132977	6	173	200	14,8-19,8 4093-A4
4003-10 BAS. MB	21,53	133042	6	283	250	19-24 4093-A3
4003-10 ENT. MB	21,68	133110	6	283	250	19-24 4093-A3
4003-10 FIN. MB	23,27	133172	6	283	250	19-24 4093-A3

Half-round file.



▶ MECHANICAL ROUNDED FILE 4004

REF.	€	8 41 4299	g	A mm	B mm	M
4004-4 BAS.	6,59	412109	12	10	100	2-3,8 4089-1/4090-1/4093-B5
4004-4 ENT.	6,70	412307	12	10	100	2-3,8 4089-1/4090-1/4093-B5
4004-4 FIN.	7,17	412505	12	10	100	2-3,8 4089-1/4090-1/4093-B5
4004-6 BAS.	8,32	413304	12	29	150	3,5-5,8 4089-2/4090-2/4093-B4
4004-6 ENT.	8,37	413502	12	29	150	3,5-5,8 4089-2/4090-2/4093-B4
4004-6 FIN.	8,92	413908	12	29	150	3,5-5,8 4089-2/4090-2/4093-B4
4004-8 BAS.	9,55	414103	12	73	200	5-7,5 4089-3/4090-3/4093-B4
4004-8 ENT.	9,85	414301	12	73	200	5-7,5 4089-3/4090-3/4093-B4
4004-8 FIN.	10,94	414707	12	73	200	5-7,5 4089-3/4090-3/4093-B4
4004-10 BAS.	13,23	414905	12	143	250	6-9,4 4089-4/4090-4/4093-B3
4004-10 ENT.	13,46	415100	12	143	250	6-9,4 4089-4/4090-4/4093-B3
4004-10 FIN.	14,70	415308	12	143	250	6-9,4 4089-4/4090-4/4093-B3
4004-12 BAS.	17,06	415506	6	278	300	7-11,4 4089-4/4090-4/4093-B3
4004-12 ENT.	18,11	415704	6	278	300	7-11,4 4089-4/4090-4/4093-B3
4004-12 FIN.	19,14	415902	6	278	300	7-11,4 4089-4/4090-4/4093-B3

Round file.



▶ BIMATERIAL HANDLE MECHANICAL ROUNDED FILE 4004

REF.	€	8 41 4299	g	A mm	B mm	M
4004-4 BAS. MB	8,68	133769	6	40	100	2-3,8 4093-B5
4004-4 ENT. MB	8,64	133820	6	40	100	2-3,8 4093-B5
4004-4 FIN. MB	8,95	133868	6	40	100	2-3,8 4093-B5
4004-6 BAS. MB	10,27	133929	6	75	150	3,5-5,8 4093-B4
4004-6 ENT. MB	10,23	133998	6	75	150	3,5-5,8 4093-B4
4004-6 FIN. MB	10,82	134070	6	75	150	3,5-5,8 4093-B4
4004-8 BAS. MB	11,38	134124	6	135	200	5-7,5 4093-B4
4004-8 ENT. MB	11,55	134193	6	135	200	5-7,5 4093-B4
4004-8 FIN. MB	12,55	134278	6	135	200	5-7,5 4093-B4
4004-10 BAS. MB	15,21	134346	6	203</		

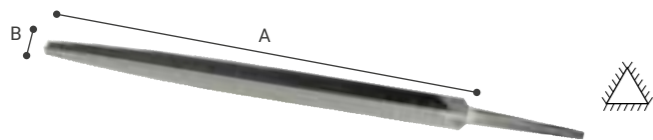

► MECHANICAL TRIANGULAR FILE 4005

REF.	€	8 41 4299	g	A mm	B mm	M
4005-4 BAS.	7,04	416800	12 22	100	5,5-8,5	4089-2/4090-1/4093-B4
4005-4 ENT.	7,27	417005	12 22	100	5,5-8,5	4089-2/4090-1/4093-B4
4005-4 FIN.	7,79	417203	12 22	100	5,5-8,5	4089-2/4090-1/4093-B4
4005-6 BAS.	9,43	418002	12 77	150	8-12,5	4089-3/4090-3/4093-B3
4005-6 ENT.	9,78	418200	12 77	150	8-12,5	4089-3/4090-3/4093-B3
4005-6 FIN.	10,75	418606	12 77	150	8-12,5	4089-3/4090-3/4093-B3
4005-8 BAS.	11,88	418903	12 160	200	10,5-15,6	4089-4/4090-4/4093-B2
4005-8 ENT.	12,54	419108	12 160	200	10,5-15,6	4089-4/4090-4/4093-B2
4005-8 FIN.	13,39	419405	12 160	200	10,5-15,6	4089-4/4090-4/4093-B2
4005-10 BAS.	17,06	419603	12 285	250	11-17,8	4089-7/4090-5/4093-B1
4005-10 ENT.	18,21	419801	12 285	250	11-17,8	4089-7/4090-5/4093-B1
4005-10 FIN.	19,48	420005	12 285	250	11-17,8	4089-7/4090-5/4093-B1
4005-12 BAS.	23,02	420203	6 450	300	12,5-20,6	4090-6/4093-B1
4005-12 ENT.	24,21	420401	6 450	300	12,5-20,6	4090-6/4093-B1
4005-12 FIN.	25,82	420609	6 450	300	12,5-20,6	4090-6/4093-B1

Triangular file.



► MECHANICAL SQUARE FILE 4006

REF.	€	8 41 4299	g	A mm	B mm	M
4006-4 BAS.	8,48	422009	12 13	100	1,6-3,8	4089-1/4090-1/4093-B5
4006-4 ENT.	8,63	422207	12 13	100	1,6-3,8	4089-1/4090-1/4093-B5
4006-4 FIN.	8,82	422405	12 13	100	1,6-3,8	4089-1/4090-1/4093-B5
4006-6 BAS.	9,54	423204	12 39	150	2,9-5,4	4089-2/4090-2/4093-B4
4006-6 ENT.	9,84	423402	12 39	150	2,9-5,4	4089-2/4090-2/4093-B4
4006-6 FIN.	10,52	423600	12 39	150	2,9-5,4	4089-2/4090-2/4093-B4
4006-8 BAS.	10,94	423907	12 91	200	4,5-7,1	4089-3/4090-3/4093-B4
4006-8 ENT.	11,32	424102	12 91	200	4,5-7,1	4089-3/4090-3/4093-B4
4006-8 FIN.	12,14	424300	12 91	200	4,5-7,1	4089-3/4090-3/4093-B4
4006-10 BAS.	14,39	424508	12 180	250	5,6-9	4089-4/4090-4/4093-B3
4006-10 ENT.	15,52	424706	12 180	250	5,6-9	4089-4/4090-4/4093-B3
4006-12 BAS.	19,48	425109	6 313	300	6,6-11,6	4089-4/4090-4/4093-B2
4006-12 ENT.	20,29	425307	6 313	300	6,6-11,6	4089-4/4090-4/4093-B2
4006-12 FIN.	21,75	425505	6 313	300	6,6-11,6	4089-4/4090-4/4093-B2

Square file.



► MECHANICAL FLAT THIN FILE 4007

REF.	€	8 41 4299	g	A mm	B mm	M
4007-6 BAS.	10,99	426908	12 30	150	1,8-15,6	4089-4/4090-3/4093-B3
4007-6 ENT.	11,32	427103	12 30	150	1,8-15,6	4089-4/4090-3/4093-B3
4007-6 FIN.	11,78	427301	12 30	150	1,8-15,6	4089-4/4090-3/4093-B3

Flat file. Four sides.



► BIMATERIAL HANDLE MECHANICAL TRIANGULAR FILE 4005

REF.	€	8 41 4299	g	A mm	B mm	M
4005-4 ENT. MB	8,96	134728	6 60	100	5,5-8,5	4093-B4
4005-6 BAS. MB	11,34	134797	6 127	150	8-12,5	4093-B3
4005-6 ENT. MB	11,55	134872	6 127	150	8-12,5	4093-B3
4005-6 FIN. MB	12,33	134940	6 127	150	8-12,5	4093-B3
4005-8 BAS. MB	13,69	135015	6 225	200	10,5-15,6	4093-B2
4005-8 ENT. MB	13,84	135077	6 225	200	10,5-15,6	4093-B2
4005-8 FIN. MB	15,21	135145	6 225	200	10,5-15,6	4093-B2
4005-10 BAS. MB	18,74	135282	6 357	250	11-17,8	4093-B1
4005-10 ENT. MB	19,50	135350	6 357	250	11-17,8	4093-B1
4005-10 FIN. MB	20,82	135428	6 357	250	11-17,8	4093-B1

Triangular file.



► BIMATERIAL HANDLE MECHANICAL SQUARE FILE 4006

REF.	€	8 41 4299	g	A mm	B mm	M
4006-4 BAS. MB	10,50	135688	6 43	100	1,6-3,8	4093-B5
4006-4 ENT. MB	10,60	135756	6 43	100	1,6-3,8	4093-B5
4006-4 FIN. MB	10,77	135824	6 43	100	1,6-3,8	4093-B5
4006-6 BAS. MB	11,91	135848	6 77	150	2,9-5,4	4093-B4
4006-6 ENT. MB	11,98	135916	6 77	150	2,9-5,4	4093-B4
4006-6 FIN. MB	12,33	136081	6 77	150	2,9-5,4	4093-B4
4006-8 BAS. MB	13,47	135978	6 140	200	4,5-7,1	4093-B4
4006-8 ENT. MB	13,85	136043	6 140	200	4,5-7,1	4093-B4
4006-8 FIN. MB	13,90	136234	6 140	200	4,5-7,1	4093-B4
4006-10 BAS. MB	16,35	136296	6 243	250	5,6-9	4093-B3
4006-10 ENT. MB	17,08	136357	6 243	250	5,6-9	4093-B3
4006-10 FIN. MB	18,36	136425	6 243	250	5,6-9	4093-B3

Square file.

NEEDLE FILES

• For use by watchmakers, jewellery makers and engravers.



► NEEDLE FLAT POINTED FILE 4071

REF.	€	8 41 4299	g	A mm	B mm
4071-16 BAS.	8,69	444506	12 8	92	5,96
4071-16 ENT.	8,69	444902	12 8	92	5,96
4071-16 FIN.	8,69	445107	12 8	92	5,96



► NEEDLE HALF ROUNDED FILE 4074

REF.	€	8 41 4299	g	A mm	B mm
4074-16 BAS.	14,11	446906	12 9	92	5,5
4074-16 ENT.	14,11	447309	12 9	92	5,5
4074-16 FIN.	14,11	447507	12 9	92	5,5

Half-round file.



► NEEDLE FLAT PARALLEL FILE 4076

REF.	€	8 41 4299	g	A mm	B mm
4076-16 BAS.	8,69	448702	12 9	92	6
4076-16 ENT.	8,69	449105	12 9	92	6
4076-16 FIN.	8,69	449303	12 9	92	6

Flat file. Four sides.



► NEEDLE FILE KIT 4077

REF.	€	8 41 4299	g	A mm	B mm	C mm
4077-16	104,57	466201	1	150	170	45 20
4071-16 BAS		4071-16 FIN		4072-16 BAS		
4072-16 FIN		4073-16 BAS		4073-16 FIN		
4074-16 BAS		4074-16 FIN		4075-16 BAS		
4075-16 FIN		4076-16 BAS		4076-16 FIN		



► NEEDLE ROUNDED FILE 4072

REF.	€	8 41 4299	g	A mm	B mm
4072-16 BAS.	7,30	445305	12 9	92	2,92
4072-16 ENT.	7,30	445701	12 9	92	2,92
4072-16 FIN.	7,30	445909	12 9	92	2,92

Round file.



► NEEDLE TRIANGULAR FILE 4075

REF.	€	8 41 4299	g	A mm	B mm
4075-16 BAS.	8,24	447903	12 9	92	3,5
4075-16 ENT.	8,24	448306	12 9	92	3,5
4075-16 FIN.	8,24	448504	12 9	92	3,5

Triangular file.



► NEEDLE FILE KIT 4078

REF.	€	8 41 4299	g	A mm	B mm	C mm
4078-16	52,34	466300	1	60	190	120 7
4071-16 BAS		4072-16 BAS		4073-16 BAS		
4074-16 BAS		4075-16 BAS		4076-16 BAS		

CARPENTER'S RASPS

• For work in wooden joinery.



▶ HALF ROUNDED CARPENTRY RASP 4101

REF.	€	8 41 4299	g	A mm	B mm	M
4101-6 BAS.	17,58	453805	12	59	150	15
4101-6 ENT.	17,59	454000	12	59	150	15
4101-6 FIN.	18,70	454208	12	59	150	14
4101-8 BAS.	19,56	454406	12	119	200	19,5
4101-8 ENT.	20,58	454604	12	119	200	19,5
4101-8 FIN.	25,01	454802	12	119	200	19,5
4101-10 BAS.	23,06	455007	12	229	250	24
4101-10 ENT.	26,70	455205	12	229	250	24
4101-10 FIN.	31,56	455403	12	229	250	24
4101-12 BAS.	27,58	455601	6	375	300	28,5
4101-12 ENT.	31,17	455809	6	375	300	28,5
4101-12 FIN.	36,63	456004	6	375	300	28,5

Half-round file.



▶ BIMATERIAL HANDLE HALF ROUNDED CARPENTRY RASP 4101

REF.	€	8 41 4299	g	A mm	B mm	M
4101-6 BAS. MB	19,99	136487	6	107	150	15
4101-6 ENT. MB	19,85	137583	6	107	150	15
4101-8 BAS. MB	22,51	137637	6	177	200	19,5
4101-8 ENT. MB	23,78	137699	6	177	200	19,5
4101-10 BAS MB	25,62	137767	6	290	250	24
4101-10 ENT MB	28,11	137835	6	290	250	24

Half-round file.



▶ HALF ROUNDED WOODWORKING RASP 4102

REF.	€	8 41 4299	g	A mm	B mm	M
4102-6 ENT.	17,65	456400	12	59	150	19
4102-8 BAS.	19,18	457001	12	59	150	19
4102-8 ENT.	20,78	457209	12	121	200	24
4102-10 BAS.	23,06	457803	12	121	200	24
4102-10 ENT.	25,09	458008	12	210	250	29

Half-round file.



▶ BIMATERIAL HANDLE HALF ROUNDED WOODWORKING RASP 4102

REF.	€	8 41 4299	g	A mm	B mm	M
4102-6 BAS. MB	20,24	138023	6	123	150	19
4102-6 ENT. MB	19,99	138085	6	123	150	19
4102-8 BAS. MB	22,22	138146	6	192	200	24
4102-8 ENT. MB	24,57	138214	6	192	200	24
4102-10 BAS MB	25,33	138276	6	300	250	29
4102-10 ENT MB	27,24	138337	6	300	250	29

Half-round file.



▶ FLAT POINTED RASP 4103

REF.	€	8 41 4299	g	A mm	B mm	M
4103-8 ENT.	21,20	459708	12	154	200	20

Flat file.



▶ BIMATERIAL HANDLE FLAT POINTED RASP 4103

REF.	€	8 41 4299	g	A mm	B mm	M
4103-8 ENT. MB	23,73	086133	6	237	200	20

Flat file.



▶ ROUNDED RASP 4104

REF.	€	8 41 4299	g	A mm	B mm	M
4104-6 BAS.	9,21	461008	12	29	150	6
4104-6 ENT.	10,24	461206	12	29	150	6
4104-8 ENT.	13,72	462005	12	71	200	8
4104-10 BAS.	15,45	462609	12	71	200	8
4104-10 ENT.	17,03	462807	12	143	250	10

Round file.



▶ BIMATERIAL HANDLE ROUNDED RASP 4104

REF.	€	8 41 4299	g	A mm	B mm	M
4104-6 BAS. MB	12,23	138436	6	75	150	6
4104-6 ENT. MB	12,91	138498	6	75	150	6
4104-8 ENT. MB	16,04	138610	6	138	200	8
4104-10 BAS MB	17,87	138658	6	200	250	10
4104-10 ENT MB	19,38	138702	6	200	250	10

Round file.

PLATE SANDERS AND RASPS

SURFACE FORMING FILE:

- Toughened carbon blue steel blade: long life.
- Very resistant metal body.
- 4.6 mm blade edge pass: rapid and fine finish.

Uses:

- For grinding or adjusting the cut on drywall.

DRYWALL SANDER:

- ABS rubber base for a better fit to the surface to be polished.
- With abrasive paper: fast and good finishing.
- Handle designed to match the use and the user: very ergonomic.
- Quick change clamp.
- Light and strong.

Uses:

- Smoothing joints.



▶ SURFACE FORMING FILE 4107-140

REF.	€	8 41 4299	g	A mm	B mm	C mm
4107-140	13,77	561340	6	190	42	150



▶ SURFACE FORMING FILE 4107-260

REF.	€	8 41 4299	g	A mm	B mm	C mm
4107-260	23,66	561364	6	380	45	280



▶ DRYWALL HAND SANDER 50272

REF.	€	8 41 4299	g	A mm	B mm	C mm
50272	14,02	564624	2	342	78	80



▶ SANDERS FOR DRYWALL SANDER 50273

REF.	€	8 41 4299	g	A mm	B mm	C mm
50273	10,75	565195	5	203	107	315



▶ BLADE FOR SURFACE FORMING FILE H4107-140

REF.	€	8 41 4299	g	A mm	B mm	C mm
H4107-140	6,80	563573	10	30	13	42

Pack With 2 units.



▶ SURFACE FORMING FILE 4107-260

REF.	€	8 41 4299	g	A mm	B mm	C mm
H4107-260	7,78	563603	10	40	13	42

Pack With 2 units.



Feel free.
Step with confidence.



Everything
you need
for your safety

**FOR
YOUR SAFETY**



FOOTWEAR

1
2
3

- ▶ **Designed for you:**
Different models for all uses. They adapt to your feet and your needs.
- ▶ **More comfortable:**
Padded inside, comfortable and flexible. You won't even realise you are wearing them.
- ▶ **Non-slip:**
With the non-slip SR sole you get extra safety and strength. Stomp your feet and obtain your goals.

CHARACTERISTICS

- Work safely with our professional footwear.
- Non-slip boots and shoes, water, oil and fuel resistant, with a reinforced toe cap, anti-perforation insole... Make sure your feet are safe with Bellota.

USES

- Different models for all uses:
- For warehouses
 - For transport
 - For industry
 - For construction
 - For agriculture

SAFETY CATEGORIES

20345:2012

SB	Footwear with 200 J resistant toe cap
A	Anti-static safety footwear
E	Energy absorption in the heel
FO	Oil and hydrocarbons resistance
P	Perforation resistance no less than 1100N.
WRU	Water penetration and absorption resistance.
WR	Waterproof footwear.
HRO	Heat resistant sole for protection when walking on hot surfaces.
HI	Sole with heat insulation for protection when walking on hot surfaces.
CI	Sole with cold insulation for protection when walking on cold surfaces
SRA	Maximum slip resistance on tiled floors with lubricant: water with detergent.
SRC	Maximum slip resistance (tiled floor with lubricant: water with detergent and stainless steel floor with lubricant: glycerine).
ESD	It discharges the static electricity that accumulates in the body into the ground to prevent any damage to electronic devices (UNE EN 61340-5-1:2016).
S1P	SB + A + E + FO + closed heel area + P
S3	S1P + WRU + cleated outsole
S5	SB + A + E + FO + P + cleated outsole

20345:2022

SB	Footwear with 200 J resistant toe cap
A	Anti-static safety footwear
E	Energy absorption in the heel
FO	Oil and hydrocarbons resistance
P	Metal puncture resistance not less than 1100N.
PL	FabricE puncture resistance not less than 1100N with a 4.5mm tip.
PS	FabricE puncture resistance not less than 1100N with a 3 mm tip.
WPA	Water penetration and absorption resistance.
WR	Waterproof footwear.
HRO	Heat resistant sole for protection when walking on hot surfaces.
HI	Sole with heat insulation for protection when walking on hot surfaces.
CI	Sole with cold insulation for protection when walking on cold surfaces
SR	Maximum slip resistance on ceramic floor with glycerine. Heel and tenar test.
ESD	It discharges the static electricity that accumulates in the body into the ground to prevent any damage to electronic devices (UNE EN 61340-5-1:2016).
S1P/PL/PS	SB + A + E + closed heel area + P/PL/PS.
S2	SB + A + E + closed heel area
S3/PL/PS	S1P/PL/PS + WPA + sola com ressaltos
S5/PL/PS	SB + A + E + P/PL/PS + cleated outsole
S7/PL/PS	S3P/PL/PS + WR

OUR FOOTWEAR

RANGE	REF.	SAFETY CATEGORY 2012	SAFETY CATEGORY 2022	TOE CAP	ANTI-PERFORATION INSOLE	
CLASSIC	72305S1P	S1P (SB A E FO P) SRC	S1P (SB A E P WPA) FO SR	Metallic	Metallic	
	72304S1P	S1P (SB A E FO P) SRC	S1P (SB A E P WPA) FO SR	Metallic	Metallic	
	72306S1P	S1P (SB A E FO P) SRC	S1P (SB A E P WPA) FO SR	Metallic	Metallic	
	72301S3	S3 (SB A E FO P WRU) SRC	S3 (SB A E P WPA) FO SR	Metallic	Metallic	
	72300S3	S3 (SB A E FO P WRU) SRC	S3 (SB A E P WPA) FO SR	Metallic	Metallic	
	72302S3	S3 (SB A E FO P WRU) SRC	S3 (SB A E P WPA) FO SR	Metallic	Metallic	
	72303S3	S3 (SB A E FO P WRU) SRC	S3 (SB A E P WPA) FO SR	Metallic	Metallic	
	72301LNTS3	S3 (SB A E FO P WRU) HRO HI CI SRC	S3 (SB A E P WPA) FO SR HRO HI CI	Metallic	Metallic	
	72300LNTS3	S3 (SB A E FO P WRU) HRO HI CI SRC	S3 (SB A E P WPA) FO SR HRO HI CI	Metallic	Metallic	
	72310S1P	S1P (SB A E FO P) SRC	S1PS (SB A E PS WPA) FO SR	Fiber glass	Fabric	
COMP+	72312S1P	S1P (SB A E FO P) SRC	S1PS (SB A E PS WPA) FO SR	Fiber glass	Fabric	
	72309S1P	S1P (SB A E FO P) SRC	S1PS (SB A E PS WPA) FO SR	Fiber glass	Fabric	
	72310NTS1P	S1P (SB A E FO P) HRO HI CI SRC	S1PS (SB A E PS WPA) FO SR HRO HI CI	Fiber glass	Fabric	
	72309NTS1P	S1P (SB A E FO P) HRO HI CI SRC	S1PS (SB A E PS WPA) FO SR HRO HI CI	Fiber glass	Fabric	
	72308S3	S3 (SB A E FO P WRU) SRC	S3S (SB A E PS WPA) FO SR	Fiber glass	Fabric	
	72307S3	S3 (SB A E FO P WRU) SRC	S3S (SB A E PS WPA) FO SR	Fiber glass	Fabric	
	72311S3	S3 (SB A E FO P WRU) SRC	S3S (SB A E PS WPA) FO SR	Fiber glass	Fabric	
	72307GJS3	S3 (SB A E FO P WRU) SRC	S3S (SB A E PS WPA) FO SR	Fiber glass	Fabric	
	72307NJS3	S3 (SB A E FO P WRU) SRC	S3S (SB A E PS WPA) FO SR	Fiber glass	Fabric	
	72308GJS3	S3 (SB A E FO P WRU) SRC	S3S (SB A E PS WPA) FO SR	Fiber glass	Fabric	
NON METAL	72308NJS3	S3 (SB A E FO P WRU) SRC	S3S (SB A E PS WPA) FO SR	Fiber glass	Fabric	
	72309GJS1P	S1P (SB A E FO P) SRC	S1PS (SB A E PS WPA) FO SR	Fiber glass	Fabric	
	72310GJS1P	S1P (SB A E FO P) SRC	S1PS (SB A E PS WPA) FO SR	Fiber glass	Fabric	
	72226S1P	S1P (SB A E FO P) SRC	-	Fiber glass	Fabric	
	72227S1P	S1P (SB A E FO P) SRC	-	Fiber glass	Fabric	
	72221S1P	S1P (SB A E FO P) SRC	-	Fiber glass	Fabric	
	CLICK	72213S3	S3 (SB A E FO P WRU) SRC	S3S (SB A E PS WPA) FO SR	Fiber glass	Fabric
	AGRO	FTW01B02	O2 (OB A E WRU) WR SRA	-	-	-
		FTW01BS3	S3 (SB A E FO P WRU) WR SRA	S7S (SB A E WR P WPA) FO SR HRO HI CI	Fiber glass	Fabric
	ALLTRACK	72320MNS3	S3 (SB A E FO P WRU) SRC	S3S (SB A E PS WPA) FO SR	Fiber glass	Fabric
72321MNS3		S3 (SB A E FO P WRU) SRC	S3S (SB A E PS WPA) FO SR CI	Fiber glass	Fabric	
FLEX	FTW02BS1P	S1P (SB A E FO P) SRC	S1PS (SB A E PS WPA) FO SR	Fiber glass	Fabric	
	FTW04GS1P	S1P (SB A E FO P) SRC ESD	S1PS (SB A E PS WPA) FO SR - ESD	Fiber glass	Fabric	
	FTW05BOS1P	S1P (SB A E FO P) SRC ESD	S1PS (SB A E PS WPA) FO SR - ESD	Fiber glass	Fabric	
	FTW05BYS1P	S1P (SB A E FO P) SRC ESD	S1PS (SB A E PS WPA) FO SR - ESD	Fiber glass	Fabric	
	FTW03BS3	S3 (SB A E FO P WRU) SRC ESD	S3S (SB A E PS WPA) FO SR - ESD	Fiber glass	Fabric	
	FTW07BS3	S3 (SB A E FO P WRU) SRC ESD	-	Fiber glass	Fabric	
STREET	72350BBS1P	S1P (SB A E FO P) HRO CI SRC	-	Aluminium	Fabric	
	72350BRS1P	S1P (SB A E FO P) HRO CI SRC	-	Aluminium	Fabric	
INDUSTRY	72351BS1P	S1P (SB A E FO P) HRO CI SRC	-	Aluminium	Fabric	
	72352BS1P	S1P (SB A E FO P) HRO CI SRC	-	Aluminium	Fabric	
	RUNAS3S	-	S3S (SB A E PS WPA) FO SR CI - ESD	Fiber glass	Fabric	
RUNNING	RUNBS3S	-	S3S (SB A E PS WPA) FO SR CI - ESD	Fiber glass	Fabric	
	RUNJS3S	-	S3S (SB A E PS WPA) FO SR CI - ESD	Fiber glass	Fabric	
	RUNNS3S	-	S3S (SB A E PS WPA) FO SR CI - ESD	Fiber glass	Fabric	
	72224KBS1P	S1P (SB A E FO P) SRC	-	Fiber glass	Fabric	
	72224NBS1P	S1P (SB A E FO P) SRC	-	Fiber glass	Fabric	
	72223BS3	S3 (SB A E FO P WRU) SRC	-	Fiber glass	Fabric	
CORE	72223NBS3	S3 (SB A E FO P WRU) SRC	-	Fiber glass	Fabric	
	FTW3050S1P	S1P (SB A E FO P) SRC	S1PS (SB A E PS WPA) FO SR	Steel	Fabric	
	FTW4091S1P	S1P (SB A E FO P) SRC	S1PS (SB A E PS WPA) FO SR	Fiber glass	Fabric	
VOLTA	FTW4051S3	S3 (SB A E FO P WRU) SRC	S3S (SB A E PS WPA) FO SR	Fiber glass	Fabric	
	FTW5074S3	S3 (SB A E FO P WRU) SRC	S3S (SB A E PS WPA) FO SR	Fiber glass	Fabric	
RACE	72323CGS2	S2 (SB A E FO WRU) SRC	S2 (SB A E WPA) FO SR	Metallic	-	
	72324CGS2	S2 (SB A E FO WRU) SRC	S2 (SB A E WPA) FO SR	Metallic	-	
	72325NNS2	S2 (SB A E FO WRU) SRC	S2 (SB A E WPA) FO SR	Metallic	-	
	72326NNS2	S2 (SB A E FO WRU) SRC	S2 (SB A E WPA) FO SR	Metallic	-	
	72242S5	S5 (SB A E FO P WR) SRA	S5 (SB A E P WR) FO SR.	Metallic	Metallic	
CHEF	72243S5	S5 (SB A E FO P WR) SRA	S5 (SB A E P WR) FO SR.	Metallic	Metallic	
	72241B	OB SRA	-	-	-	
WATER	72243S5	S5 (SB A E FO P WR) SRA	S5 (SB A E P WR) FO SR.	Metallic	Metallic	
	72241B	OB SRA	-	-	-	

RUNNING RANGE

1
2
3

► **Durability**

Our FORTITEX™ fabric with anti-abrasion technology combined with front, rear and side reinforcements give this range unrivalled durability.

► **Advanced Comfort**

The Open Cell PRO technology and PU+GEL insole in this shoe will provide you with superior shock absorption, stability and comfort. So you won't feel fatigued after the day's work.

► **Made in Spain**

100% Developed and manufactured in Spain with state-of-the-art manufacturing processes.

USES



SAFETY CATEGORY



REINFORCED HEEL PAD FOR GREATER STABILITY AND RESISTANCE.

FORTITEX™ WRU CERTIFIED: BREATHABLE AND WATERPROOF.

ERGONOMIC COLLAR AND 3D MESH PADDING. BREATHABILITY, MOISTURE ABSORPTION AND COMFORT.

EXTRA PADDED TONGUE.

FIBREGLASS TOE CAP.

DISCOVER THE RUNNING RANGE

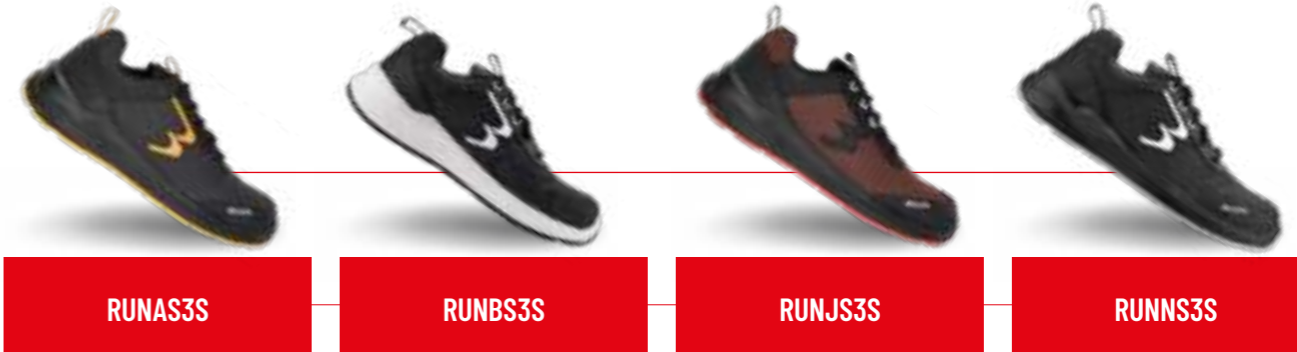

FEATURES



MORE COMFORT
GEL INNER SOLE

Open CELL + GEL - Open cell and elastic memory to absorb impacts and recover its shape.

AeroFlow - Maximum breathability for cool, dry and comfortable footwear.



INCREASED DURABILITY
ANTI-ABRASION RUBBER

Front, rear and side reinforcements in the areas where most rubbing and impact occurs, allowing us to give the shoe a higher degree of protection and durability.



TECHNOLOGIES

FORTITEX™

Increased strength and durability thanks to the inclusion of the second generation combination of **microfibre and polyurethane yarns.**

OPEN CELL

This is a manufacturing technology developed by Bellota based on the inclusion of air microparticles in the composition together with a new generation of polyurethane to achieve



maximum lightness and cushioning in footwear.

CLASSIC RANGE

- Footwear certified as Category II according to EN ISO 20345 standard.
- Metallic safety toe cap and antiperforation insole.

Sole:

- SRC/SR dual density PU + PU: maximum anti-slip performance certifiable according to ISO 20345 standard.
- Sole design for safety and durability: wide grooves, braking zones, shock absorption, textured shank and raised toe and rear profiles.

Nitrile soles:

- Stitched nitrile sole for the most extreme conditions without losing comfort: contact heat resistant (HRO), sole heat insulating (HI), floor cold insulating (CI) and SRC maximum slip resistance according to ISO 20345 standard.
- Sole design for safety and durability: wide grooves, braking zones, shock absorption, textured shank and raised toe and rear profiles.

Style:

- S1P versions in suede leather: more breathable and lighter.
- S3P versions in waterproof, moisture-resistant leather.
- Padded collar, gusseted tongue.
- Bellota Mesh padded lining: better ventilation and extra comfort.
- Wide last.

Uses:

- For general use where safety footwear is required. Functionality.

Uses of nitrile products:

- For use under the most extreme conditions requiring safety footwear. Functionality.
- For general use where heavy-duty safety footwear is required.
- Storage, transport, industry and construction.



► LEATHER BOOT S3 72300

REF.	€	8 41 4299	Mbox	
72300-36 S3	32,26	640342	1	10 36
72300-37 S3	32,26	640366	1	10 37
72300-38 S3	32,26	640380	1	10 38
72300-39 S3	32,26	640403	1	10 39
72300-40 S3	32,26	640427	1	10 40
72300-41 S3	32,26	640441	1	10 41
72300-42 S3	32,26	640465	1	10 42
72300-43 S3	32,26	640489	1	10 43
72300-44 S3	32,26	640502	1	10 44
72300-45 S3	32,26	640526	1	10 45
72300-46 S3	32,26	640823	1	10 46
72300-47 S3	32,26	640540	1	10 47
72300-48 S3	32,26	640564	1	10 48

S3 (SB A E FO P WRU) SRC.

*In the process of recertification under standard 20345:2022 CAT S3 (SB A E P WPA) FO SR.

*Also available in anti-hydrolysis version 72300L-S3.



► LEATHER SHOE S3 72301

REF.	€	8 41 4299	Mbox	
72301-36 S3	31,25	640588	1	10 36
72301-37 S3	31,25	640601	1	10 37
72301-38 S3	31,25	640847	1	10 38
72301-39 S3	31,25	640625	1	10 39
72301-40 S3	31,25	640649	1	10 40
72301-41 S3	31,25	640663	1	10 41
72301-42 S3	31,25	640687	1	10 42
72301-43 S3	31,25	640748	1	10 43
72301-44 S3	31,25	640700	1	10 44
72301-45 S3	31,25	640724	1	10 45
72301-46 S3	31,25	640762	1	10 46
72301-47 S3	31,25	640786	1	10 47
72301-48 S3	31,25	640809	1	10 48

S3 (SB A E FO P WRU) SRC.

*In the process of recertification under standard 20345:2022 CAT S3 (SB A E P WPA) FO SR.

*Also available in anti-hydrolysis version 72301L-S3.



► WELDING LEATHER BOOT S3-72302

REF.	€	8 41 4299	Mbox	
72302-36 S3	36,71	154054	1	10 36
72302-37 S3	36,71	376210	1	10 37
72302-38 S3	36,71	642148	1	10 38
72302-39 S3	36,71	642162	1	10 39
72302-40 S3	36,71	642186	1	10 40
72302-41 S3	36,71	642209	1	10 41
72302-42 S3	36,71	642223	1	10 42
72302-43 S3	36,71	642247	1	10 43
72302-44 S3	36,71	642261	1	10 44
72302-45 S3	36,71	642285	1	10 45
72302-46 S3	36,71	642308	1	10 46
72302-47 S3	36,71	642322	1	10 47

S3 (SB A E FO P WRU) SRC.

*In the process of recertification under standard 20345:2022 CAT S3 (SB A E P WPA) FO SR.



► REINFORCED LEATHER BOOT S3-72303

REF.	€	8 41 4299	Mbox	
72303-36 S3	36,06	642346	1	10 36
72303-37 S3	36,06	642360	1	10 37
72303-38 S3	36,06	643220	1	10 38
72303-39 S3	36,06	642384	1	10 39
72303-40 S3	36,06	642407	1	10 40
72303-41 S3	36,06	642421	1	10 41
72303-42 S3	36,06	643244	1	10 42
72303-43 S3	36,06	642445	1	10 43
72303-44 S3	36,06	642469	1	10 44
72303-45 S3	36,06	642483	1	10 45
72303-46 S3	36,06	642506	1	10 46
72303-47 S3	36,06	642520	1	10 47

S3 (SB A E FO P WRU) SRC.

*In the process of recertification under standard 20345:2022 CAT S3 (SB A E P WPA) FO SR.



► SUEDE LEATHER BOOT S1P-72304

REF.	€	8 41 4299	Mbox	
72304-36 S1P	33,32	642544	1	10 36
72304-37 S1P	33,32	642568	1	10 37
72304-38 S1P	33,32	642582	1	10 38
72304-39 S1P	33,32	642605	1	10 39
72304-40 S1P	33,32	642629	1	10 40
72304-41 S1P	33,32	643268	1	10 41
72304-42 S1P	33,32	642643	1	10 42
72304-43 S1P	33,32	642667	1	10 43
72304-44 S1P	33,32	642681	1	10 44
72304-45 S1P	33,32	642704	1	10 45
72304-46 S1P	33,32	642728	1	10 46
72304-47 S1P	33,32	642742	1	10 47

S1P (SB A E FO P) SRC.

*In the process of recertification under standard 20345:2022 CAT S1P (SB A E P WPA) FO SR.



► SUEDE LEATHER SHOE S1P-72305

REF.	€	8 41 4299	Mbox	
72305-36 S1P	31,77	642766	1	10 36
72305-37 S1P	31,77	642780	1	10 37
72305-38 S1P	31,77	642803	1	10 38
72305-39 S1P	31,77	642827	1	10 39
72305-40 S1P	31,77	642841	1	10 40
72305-41 S1P	31,77	642865	1	10 41
72305-42 S1P	31,77	642889	1	10 42
72305-43 S1P	31,77	642902	1	10 43
72305-44 S1P	31,77	642926	1	10 44
72305-45 S1P	31,77	643282	1	10 45
72305-46 S1P	31,77	642940	1	10 46
72305-47 S1P	31,77	642964	1	10 47

S1P (SB A E FO P) SRC.

*In the process of recertification under standard 20345:2022 CAT S1P (SB A E P WPA) FO SR.



► SUEDE LEATHER-CANVAS BOOT S1P-72306

REF.	€	8 41 4299	Mbox	
72306-36 S1P	34,10	642988	1	10 36
72306-37 S1P	34,10	643008	1	10 37
72306-38 S1P	34,10	643022	1	10 38
72306-39 S1P	34,10	643046	1	10 39
72306-40 S1P	34,10	643060	1	10 40
72306-41 S1P	34,10	643084	1	10 41
72306-42 S1P	34,10	643107	1	10 42
72306-43 S1P	34,10	643121	1	10 43
72306-44 S1P	34,10	643145	1	10 44
72306-45 S1P	34,10	643169	1	10 45
72306-46 S1P	34,10	643183	1	10 46
72306-47 S1P	34,10	643206	1	10 47

S1P (SB A E FO P) SRC.

*In the process of recertification under standard 20345:2022 CAT S1P (SB A E P WPA) FO SR.



► NITRILE BOOT S3-72300

REF.	€	8 41 4299	Mbox	
72300LNT-36 S3	36,28	046991	1	10 36
72300LNT-37 S3	36,28	705492	1	10 37
72300LNT-38 S3	36,28	086782	1	10 38
72300LNT-39 S3	36,28	086805	1	10 39
72300LNT-40 S3	36,28	682335	1	10 40
72300LNT-41 S3	36,28	682359	1	10 41
72300LNT-42 S3	36,28	682373	1	10 42
72300LNT-43 S3	36,28	682397	1	10 43
72300LNT-44 S3	36,28	682434	1	10 44
72300LNT-45 S3	36,28	682519	1	10 45
72300LNT-46 S3	36,28	682595	1	10 46
72300LNT-47 S3	36,28	682670	1	10 47

S3 (SB A E FO P WRU) HRO HI CI SRC.

*In the process of recertification under standard 20345:2022 CAT S3 (SB A E P WPA) FO SR HRO HI CI.



► NITRILE SHOE S3-72301

REF.	€	8 41 4299	Mbox	
72301LNT-36 S3	35,67	047028	1	10 36
72301LNT-37 S3	35,67	047066	1	10 37
72301LNT-38 S3	35,67	682755	1	10 38
72301LNT-39 S3	35,67	682830	1	10 39
72301LNT-40 S3	35,67	682915	1	10 40
72301LNT-41 S3	35,67	682991	1	10 41
72301LNT-42 S3	35,67	683028	1	10 42
72301LNT-43 S3	35,67	683042	1	10 43
72301LNT-44 S3	35,67	683073	1	10 44
72301LNT-45 S3	35,67	683097	1	10 45
72301LNT-46 S3	35,67	683127	1	10 46
72301LNT-47 S3	35,67	683172	1	10 47

S3 (SB A E FO P WRU) HRO HI CI SRC.

*In the process of recertification under standard 20345:2022 CAT S3 (SB A E P WPA) FO SR HRO HI CI.

COMP+ RANGE

- Footwear certified as Category II according to EN ISO 20345 standard.
- Non-metallic safety toe cap and antiperforation inner sole.

Sole:

- SRC/SR dual density PU + PU: maximum anti-slip performance certifiable according to ISO 20345 standard.
- Sole design for safety and durability: wide grooves, braking zones, shock absorption, textured shank and raised toe and rear profiles.
- Footwear certified as Category II according to EN ISO 20345 standard.

Nitrile soles:

- Stitched nitrile sole for the most extreme conditions without losing comfort: contact heat resistant (HRO), floor heat insulating (HI), floor cold insulating (CI) and SRC/SR maximum slip resistance according to current standards.
- Sole design for safety and durability: wide grooves, braking zones, shock absorption, textured shank and raised toe and rear profiles.

Style:

- S1PS versions in suede leather: more breathable and lighter.
- S3S versions in waterproof, moisture-resistant leather.
- Elements with reflective properties for extra safety.
- Padded collar, gusseted tongue.
- Bellota Mesh padded lining: better ventilation and extra comfort.
- Wide last.

Uses:

- For general use where safety footwear is required. Flexible and lightweight 100% Non Metal.
- Storage, transport, industry and construction.

Uses of nitrile products:

- For use under the most extreme conditions requiring safety footwear. Functionality.
- For general use where heavy-duty safety footwear is required.
- Storage, transport, industry and construction.



► LEATHER BOOT NON METAL S3-72307

REF.	€	8 41 4299	Mbox	
72307-36 S3	41,47	042764	1	10 36
72307-37 S3	41,47	042788	1	10 37
72307-38 S3	41,47	645835	1	10 38
72307-39 S3	41,47	645859	1	10 39
72307-40 S3	41,47	645873	1	10 40
72307-41 S3	41,47	645897	1	10 41
72307-42 S3	41,47	645910	1	10 42
72307-43 S3	41,47	645934	1	10 43
72307-44 S3	41,47	645958	1	10 44
72307-45 S3	41,47	645972	1	10 45
72307-46 S3	41,47	645996	1	10 46
72307-47 S3	41,47	646016	1	10 47
72307-48 S3	41,47	042801	1	10 48

S3 (SB A E FO P WRU) SRC.

*In the process of recertification under standard 20345:2022 CAT S3S (SB A E PS WPA) FO SR.

*Also available in anti-hydrolysis version 72307L- S3.

► LEATHER SHOE NON METAL S3-72308

REF.	€	8 41 4299	Mbox	
72308-36 S3	40,29	042863	1	10 36
72308-37 S3	40,29	042887	1	10 37
72308-38 S3	40,29	646030	1	10 38
72308-39 S3	40,29	646054	1	10 39
72308-40 S3	40,29	646078	1	10 40
72308-41 S3	40,29	646092	1	10 41
72308-42 S3	40,29	646115	1	10 42
72308-43 S3	40,29	646139	1	10 43
72308-44 S3	40,29	646153	1	10 44
72308-45 S3	40,29	646177	1	10 45
72308-46 S3	40,29	646191	1	10 46
72308-47 S3	40,29	646214	1	10 47
72308-48 S3	40,29	042900	1	10 48

S3 (SB A E FO P WRU) SRC.

*In the process of recertification under standard 20345:2022 CAT S3S (SB A E PS WPA) FO SR.

*Also available in anti-hydrolysis version: 72308L-S3



▶ WELDING LEATHER BOOT S3-72311

Table with 6 columns: REF., €, barcode, Mbox, and icons. Rows 7231138S3 to 7231148S3.

S3 (SB A E FO P WRU) SRC. *In the process of recertification under standard 20345:2022 CAT S3S (SB A E PS WPA) FO SR.



▶ SUEDE LEATHER BOOT NON METAL S1P-72309

Table with 6 columns: REF., €, barcode, Mbox, and icons. Rows 72309-36 S1P to 72309-48 S1P.

S1P (SB A E FO P) SRC. *In the process of recertification under standard 20345:2022 CAT S1PS (SB A E E PS WPA) FO SR.



▶ SUEDE LEATHER SHOE NON METAL S1P-72310

Table with 6 columns: REF., €, barcode, Mbox, and icons. Rows 72310-36S1P to 72310-48S1P.

S1P (SB A E FO P) SRC. *In the process of recertification under standard 20345:2022 CAT S1PS (SB A E PS WPA) FO SR.



▶ SUEDE LEATHER EASY SHOE S1P-72312

Table with 6 columns: REF., €, barcode, Mbox, and icons. Rows 7231238S1P to 7231247S1P.

S1P (SB A E FO P) SRC. *In the process of recertification under standard 20345:2022 CAT S1PS (SB A E PS WPA) FO SR.



▶ NITRILE BOOT S1P-72309

Table with 6 columns: REF., €, barcode, Mbox, and icons. Rows 72309NT38S1P to 72309NT47S1P.

S1P (SB A E FO P) SRC HRO HI Cl. *In the process of recertification under standard 20345:2022 CAT S1PS (SB A E PS WPA) FO SR HRO HI Cl.



▶ NITRILE SHOE S1P-72310

Table with 6 columns: REF., €, barcode, Mbox, and icons. Rows 72310NT38S1P to 72310NT47S1P.

S1P (SB A E FO P) SRC HRO HI Cl. *In the process of recertification under standard 20345:2022 CAT S1PS (SB A E PS WPA) FO SR HRO HI Cl.



▶ NUBUCK LEATHER BOOT S3-72307

Table with 6 columns: REF., €, barcode, Mbox, and icons. Rows 72307GJ S3 38 to 72307GJ S3 47.

S3 (SB A E FO P WRU) SRC. *In the process of recertification under standard 20345:2022 CAT S3S (SB A E PS WPA) FO SR.



▶ NUBUCK LEATHER SHOE S3-72308

Table with 6 columns: REF., €, barcode, Mbox, and icons. Rows 72308GJ S3 38 to 72308GJ S3 47.

S3 (SB A E FO P WRU) SRC. *In the process of recertification under standard 20345:2022 CAT S3S (SB A E PS WPA) FO SR.



▶ BLACK LEATHER BOOT S3-72307

Table with 6 columns: REF., €, barcode, Mbox, and icons. Rows 72307NJ S3 38 to 72307NJ S3 47.

S3 (SB A E FO P WRU) SRC. *In the process of recertification under standard 20345:2022 CAT S3S (SB A E PS WPA) FO SR.



▶ BLACK LEATHER SHOE S3-72308

Table with 6 columns: REF., €, barcode, Mbox, and icons. Rows 72308NJ S3 38 to 72308NJ S3 47.

S3 (SB A E FO P WRU) SRC. *In the process of recertification under standard 20345:2022 CAT S3S (SB A E PS WPA) FO SR.



▶ GREY SPLIT LEATHER BOOT S1P-72309

Table with 6 columns: REF., €, barcode, Mbox, and icons. Rows 72309GJ S1P 38 to 72309GJ S1P 47.

S1P (SB A E FO P) SRC. *In the process of recertification under standard 20345:2022 CAT S1PS (SB A E PS WPA) FO SR.



▶ GREY SPLIT LEATHER SHOE S1P-72310

Table with 6 columns: REF., €, barcode, Mbox, and icons. Rows 72310GJ S1P 38 to 72310GJ S1P 47.

S1P (SB A E FO P) SRC. *In the process of recertification under standard 20345:2022 CAT S1PS (SB A E PS WPA) FO SR.

FOR YOUR SAFETY

NONMETAL RANGE

- Footwear certified as Category II according to EN ISO 20345 standard.
- Non-metallic safety toe cap and antiperforation inner sole.

Sole:

- SRC/SR dual density PU + PU: maximum anti-slip performance certifiable according to current standards.
- Sole design for EXTRA safety and durability: wide grooves, braking zones, shock absorption, and raised toe and rear profiles.

Style:

- Leather finish:
 - AIR / EASY- MODELS in suede: more breathable and lightweight.
- TPU ankle insert for extra protection and a better fit.
- EXTRA padded collar, EXTRA padded gusset tongue and ergonomically shaped insole for greater comfort and fit.
- Bellota Mesh EXTRA padded lining 3D: better ventilation and extra comfort.
- EXTRA wide last.
- Non metal brackets: footwear 100% non-metallic.

Uses:

- For general use where safety footwear is required. Flexibility and lightness. 100% Non metal.



► AIR BOOT S1P 72221

REF.	€	8 41 4299	Mbox		
72221-38 S1P	60,06	353440	1	5	38
72221-39 S1P	60,06	353501	1	5	39
72221-40 S1P	60,06	375640	1	5	40
72221-41 S1P	60,06	375688	1	5	41
72221-42 S1P	60,06	375749	1	5	42
72221-43 S1P	60,06	375787	1	5	43
72221-44 S1P	60,06	375824	1	5	44
72221-45 S1P	60,06	375862	1	5	45
72221-46 S1P	60,06	375909	1	5	46
72221-47 S1P	60,06	375947	1	5	47

S1P (SB A E FO P) SRC.

► AIR SHOE S1P 72226

REF.	€	8 41 4299	Mbox		
72226-38 S1P	58,29	375985	1	5	38
72226-39 S1P	58,29	376029	1	5	39
72226-40 S1P	58,29	376067	1	5	40
72226-41 S1P	58,29	376630	1	5	41
72226-42 S1P	58,29	420739	1	5	42
72226-43 S1P	58,29	421781	1	5	43
72226-44 S1P	58,29	421804	1	5	44
72226-45 S1P	58,29	421828	1	5	45
72226-46 S1P	58,29	421842	1	5	46
72226-47 S1P	58,29	422290	1	5	47

S1P (SB A E FO P) SRC.



► EASY SHOE S1P-72227

REF.	€	8 41 4299	Mbox		
72227-38 S1P	58,57	425482	1	5	38
72227-39 S1P	58,57	425512	1	5	39
72227-40 S1P	58,57	425536	1	5	40
72227-41 S1P	58,57	425574	1	5	41
72227-42 S1P	58,57	429435	1	5	42
72227-43 S1P	58,57	429459	1	5	43
72227-44 S1P	58,57	429473	1	5	44
72227-45 S1P	58,57	429497	1	5	45
72227-46 S1P	58,57	429527	1	5	46
72227-47 S1P	58,57	429855	1	5	47

S1P (SB A E FO P) SRC.

CLICK RANGE

- Footwear certified as Category II according to EN ISO 20345:11.
- Non-metallic safety toe cap and antiperforation inner sole.

Sole:

- SRC/SR dual density PU + PU: maximum anti-slip performance certifiable according to current standards.
- Sole design for EXTRA safety and durability: wide grooves, braking zones, shock absorption, textured shank and VERY high toe and rear profiles.

Style:

- Waterproof nubuck leather (S3S): resistant to water penetration and absorption.
- TPU ankle insert for extra protection and a better fit, and to facilitate the removal of shoes.
- EXTRA padded collar, EXTRA padded gusset tongue and ergonomically shaped insole for greater comfort and fit.
- Bellota Mesh EXTRA padded lining 3D: better ventilation and extra comfort.
- EXTRA wide last.
- BELLOTA CLICK exclusive adjustment system that facilitates and simplifies taking it on and off. After the initial adjustment, you only have to release the side tabs to put on and take off the shoe.

Uses:

- For general use where safety footwear is required. Fit, flexibility and lightness.
- Particularly suitable for outdoor work. OUTDOOR USE.



► CLICK BOOT S3-72213

REF.	€	8 41 4299	Mbox		
72213-38 S3	77,66	060263	1	5	38
72213-39 S3	77,66	613728	1	5	39
72213-40 S3	77,66	613742	1	5	40
72213-41 S3	77,66	613766	1	5	41
72213-42 S3	77,66	613780	1	5	42
72213-43 S3	77,66	613803	1	5	43
72213-44 S3	77,66	613827	1	5	44
72213-45 S3	77,66	614084	1	5	45
72213-46 S3	77,66	613841	1	5	46
72213-47 S3	77,66	613865	1	5	47

S3 (SB A E FO P WRU) SRC.

*In the process of recertification under standard 20345:2022 CAT S3S (SB A E PS WPA) FO SR.

AGRO RANGE

- FTW01BS1P: Footwear certified in accordance with Regulation (EU) 425/2016. Shoe O2-WR.
- FTW01BS3: Footwear certified as Category II according to EN ISO 20345:11. Shoe S3-WR.
- Work footwear with waterproof fabric and sealed seams.

Sole:

- Bi-density Rubber+EVA: Rubber for increased thermal resistance, hydrocarbon resistance and slip resistance.
- EVA for lightness and cushioning.
- Sole design for safety and durability: wide grooves, braking zones, shock absorption, and raised toe and rear profiles.
- TPU insert in shank to prevent twisting of the foot and provide footstep stability.

Style:

- High quality CrazyHorse natural leather. Resistant and strong.
- TPU ankle insert for extra protection and a better fit.
- EXTRA padded collar, EXTRA padded gusseted tongue. Insole made from open-cell foam that provides greater comfort. Antistatic stitching.
- Bellota Mesh EXTRA padded lining 3D: better ventilation and extra comfort.
- Wide last.
- Anti-abrasion toe cap for greater resistance to impacts and friction.

Uses:

- FTW01B02: For general use in jobs requiring non-safety occupational footwear (no safety toecap and insole).
- Particularly suitable for outdoor work and humid environments: agriculture, gardening, rural areas, stockbreeding or mining.
- FTW01BS3: For general use in jobs requiring safety occupational footwear (with safety toecap and textile insole).
- Particularly suitable for outdoor work and humid environments: agriculture, gardening, stockbreeding or mining.



▶ AGRO BOOT O2 WR FTW01

REF.	€	8 41 4299	Mbox	
FTW0138B02	82,47	673654	1	5 38
FTW0139B02	82,47	673678	1	5 39
FTW0140B02	82,47	673746	1	5 40
FTW0141B02	82,47	673760	1	5 41
FTW0142B02	82,47	673791	1	5 42
FTW0143B02	82,47	673814	1	5 43
FTW0144B02	82,47	673838	1	5 44
FTW0145B02	82,47	673869	1	5 45
FTW0146B02	82,47	673906	1	5 46
FTW0147B02	82,47	673920	1	5 47

O2 (OB A E WRU) SRA WR.



▶ OUTDOOR BOOT WR S3-FTW01

REF.	€	8 41 4299	Mbox	
FTW0138BS3	93,36	691603	1	5 38
FTW0139BS3	93,36	691627	1	5 39
FTW0140BS3	93,36	691641	1	5 40
FTW0141BS3	93,36	691665	1	5 41
FTW0142BS3	93,36	691689	1	5 42
FTW0143BS3	93,36	691702	1	5 43
FTW0144BS3	93,36	691726	1	5 44
FTW0145BS3	93,36	691740	1	5 45
FTW0146BS3	93,36	691764	1	5 46
FTW0147BS3	93,36	691788	1	5 47

S3 (SB A E FO P WRU) SRA HRO HI CI WR.

*In the process of recertification under standard 20345:2022 CAT S7S (SB A E P WR) FO SR HRO HI CI.

ALLTRACK RANGE

- Footwear certified as Category II according to EN ISO 20345 standard.
- Non-metallic safety toe cap and antiperforation inner sole.

Sole:

- SRC/SR dual density PU + PU: Maximum anti-slip performance certifiable according to current standards.
- Sole design for safety and durability: wide grooves, braking zones, shock absorption, textured shank and raised toe and rear profiles.

Style:

- Brown Smooth Leather, splash resistant, breathable and easy to clean.
- Polyurethane insert in the ankle area for greater protection and a better fit.
- Textile inner lining to protect the upper area.
- Inner foam mesh for extra comfort and insulation.
- Textile microfibre inner reinforcement to avoid wrinkles and provide greater comfort.

Uses:

- For use in wet and/or dry conditions, industrial and/or work use. Abrasion resistant.
- Recommended for use in the oil and mining industries.



▶ ALLTRACK PETROL UNLINED BOOT S3-72320

REF.	€	8 41 4299	Mbox	
72320MN S3 38	74,00	016185	1	5 38
72320MN S3 39	74,00	016208	1	5 39
72320MN S3 40	74,00	016239	1	5 40
72320MN S3 41	74,00	016253	1	5 41
72320MN S3 42	74,00	016284	1	5 42
72320MN S3 43	74,00	016307	1	5 43
72320MN S3 44	74,00	016338	1	5 44
72320MN S3 45	74,00	016352	1	5 45
72320MN S3 46	74,00	016376	1	5 46
72320MN S3 47	74,00	016390	1	5 47

S3 (SB A E FO P WRU) SRC.

*In the process of recertification under standard 20345:2022 CAT S3S (SB A E PS WPA) FO SR.



▶ ALLTRACK PETROL BOOT WITH LINING S3-72321

REF.	€	8 41 4299	Mbox	
72321MN S3 38	76,00	015904	1	5 38
72321MN S3 39	76,00	015966	1	5 39
72321MN S3 40	76,00	015997	1	5 40
72321MN S3 41	76,00	016017	1	5 41
72321MN S3 42	76,00	016031	1	5 42
72321MN S3 43	76,00	016055	1	5 43
72321MN S3 44	76,00	016079	1	5 44
72321MN S3 45	76,00	016109	1	5 45
72321MN S3 46	76,00	016147	1	5 46
72321MN S3 47	76,00	016161	1	5 47

S3 (SB A E FO P WRU) SRC.

*In the process of recertification under standard 20345:2022 CAT S3S (SB A E PS WPA) FO SR CI.

FLEX RANGE

- Footwear certified as Category II according to EN ISO 20345 standard.
- Non-metallic safety fiberglass toe cap and antiperforation textile inner sole.
- Biomechanically tested shoes to respect the natural footprint and provide maximum comfort at work.
- ESD-certified models that divert the electrostatic discharge accumulated in the body towards the outside, preventing damage to electronic components.

Sole:

- SRC/SR dual density PU + PU: maximum anti-slip performance certifiable according to current standards.
- New sole providing safety and maximum comfort: braking zones, shock absorption, textured shank and maximum flexibility.

Style:

- Leather or Microfiber + Mesh (for strength, lightweight and breathability) depending on the model.
- EXTRA padded lining, collar and gusseted tongue for greater comfort and better ventilation.
- CONFORT PLUS insole made from open-cell foam that provides greater comfort and relieves pressure. Antistatic stitching.
- Anti-abrasion toe cap and back area for greater resistance to impacts and friction.

Uses:

- For general use where safety footwear is required. Comfortable, breathable and lightweight.
- Particularly suitable for work in restocking, handling and industry.
- ESD-certified models, suitable for work in chemical companies, in the automotive industry or in the assembly of electronic components.

Last:

- Men's size and last FTW02, FTW03, FTW04 and FTW05.
- Women's size and last FTW07.



► BLACK-ORANGE FLEX SHOE S1P-FTW05

REF.	€	PROOF	PROOF	Mbox	
FTW0538BOS1P	56,39	690163	1	5	38
FTW0539BOS1P	56,39	690187	1	5	39
FTW0540BOS1P	56,39	690200	1	5	40
FTW0541BOS1P	56,39	690224	1	5	41
FTW0542BOS1P	56,39	690248	1	5	42
FTW0543BOS1P	56,39	690262	1	5	43
FTW0544BOS1P	56,39	690286	1	5	44
FTW0545BOS1P	56,39	690309	1	5	45
FTW0546BOS1P	56,39	690323	1	5	46
FTW0547BOS1P	56,39	690347	1	5	47

S1P (SB A E FO P) SRC - ESD.
 *In the process of recertification under standard 20345:2022 CAT S1PS (SB A E PS WPA) FO SR - ESD.



► BLACK-ORANGE FLEX SHOE S1P-FTW05

REF.	€	PROOF	PROOF	Mbox	
FTW0536BYS1P	56,39	074413	1	5	36
FTW0537BYS1P	56,39	074475	1	5	37
FTW0538BYS1P	56,39	690361	1	5	38
FTW0539BYS1P	56,39	690385	1	5	39
FTW0540BYS1P	56,39	690408	1	5	40
FTW0541BYS1P	56,39	690422	1	5	41
FTW0542BYS1P	56,39	690453	1	5	42
FTW0543BYS1P	56,39	690477	1	5	43
FTW0544BYS1P	56,39	690491	1	5	44
FTW0545BYS1P	56,39	690514	1	5	45
FTW0546BYS1P	56,39	690538	1	5	46
FTW0547BYS1P	56,39	690552	1	5	47
FTW0548BYS1P	56,39	074499	1	5	48

S1P (SB A E FO P) SRC - ESD.
 *In the process of recertification under standard 20345:2022 CAT S1PS (SB A E PS WPA) FO SR - ESD.



► BEIGE FLEX SHOE S1P-FTW02

REF.	€	PROOF	PROOF	Mbox	
FTW0236BS1P	50,19	074260	1	5	36
FTW0237BS1P	50,19	074291	1	5	37
FTW0238BS1P	50,19	689563	1	5	38
FTW0239BS1P	50,19	689587	1	5	39
FTW0240BS1P	50,19	689600	1	5	40
FTW0241BS1P	50,19	689624	1	5	41
FTW0242BS1P	50,19	689648	1	5	42
FTW0243BS1P	50,19	689662	1	5	43
FTW0244BS1P	50,19	689686	1	5	44
FTW0245BS1P	50,19	689709	1	5	45
FTW0246BS1P	50,19	689723	1	5	46
FTW0247BS1P	50,19	689747	1	5	47
FTW0248BS1P	50,19	074338	1	5	48

S1P (SB A E FO P) SRC.
 *In the process of recertification under standard 20345:2022 CAT S1PS (SB A E PS WPA) FO SR.



► BLACK FLEX SPORT SHOE S1P-FTW04

REF.	€	PROOF	PROOF	Mbox	
FTW0438GS1P	52,97	689969	1	5	38
FTW0439GS1P	52,97	689983	1	5	39
FTW0440GS1P	52,97	690002	1	5	40
FTW0441GS1P	52,97	690026	1	5	41
FTW0442GS1P	52,97	690040	1	5	42
FTW0443GS1P	52,97	690064	1	5	43
FTW0444GS1P	52,97	690088	1	5	44
FTW0445GS1P	52,97	690101	1	5	45
FTW0446GS1P	52,97	690125	1	5	46
FTW0447GS1P	52,97	690149	1	5	47

S1P (SB A E FO P) SRC - ESD.
 *In the process of recertification under standard 20345:2022 CAT S1PS (SB A E PS WPA) FO SR - ESD.



► BLACK FLEX SHOE S3-FTW03

REF.	€	PROOF	PROOF	Mbox	
FTW0338BS3	55,25	689761	1	5	38
FTW0339BS3	55,25	689785	1	5	39
FTW0340BS3	55,25	689808	1	5	40
FTW0341BS3	55,25	689822	1	5	41
FTW0342BS3	55,25	689846	1	5	42
FTW0343BS3	55,25	689860	1	5	43
FTW0344BS3	55,25	689884	1	5	44
FTW0345BS3	55,25	689907	1	5	45
FTW0346BS3	55,25	689921	1	5	46
FTW0347BS3	55,25	689945	1	5	47

S3 (SB A E FO P WRU) SRC - ESD.
 *In the process of recertification under standard 20345:2022 CAT S3S (SB A E PS WPA) FO SR - ESD.



► BLACK FLEX FEMININE SHOE S3-FTW07

REF.	€	PROOF	PROOF	Mbox	
FTW073590S3	55,25	702620	1	5	35
FTW073690S3	55,25	702644	1	5	36
FTW073790S3	55,25	702668	1	5	37
FTW073890S3	55,25	702682	1	5	38
FTW073990S3	55,25	702705	1	5	39
FTW074090S3	55,25	702729	1	5	40
FTW074190S3	55,25	702743	1	5	41
FTW074290S3	55,25	702767	1	5	42

S3 (SB A E FO P WRU) SRC - ESD.

STREET & INDUSTRY RANGE

- Footwear certified in accordance with Regulation (EU) 425/2016. Safety shoe S1P.
- Non-magnetic aluminium safety toe cap and non-metallic antiperforation textile inner sole.

Sole:

- Dual density: Rubber + EVA: Rubber HRO to increase the resistance to high temperatures and it has a high slip resistance coefficient SRC/SR. EVA for lighter footwear with improved cushioning and shock absorption.
- Exclusive sole design to increase safety, oil and hydrocarbon resistance, and cold insulation (CI).

Style:

- Microfibre + Mesh: ultra-breathable.
- EXTRA padded lining, collar and gusseted tongue for greater comfort and better ventilation.
- CI: Low-temperature resistant interior.
- Insole made from open-cell foam that provides greater comfort. Antistatic stitching.
- Anti-abrasion toe cap and back area for greater resistance to impacts and friction.
- Extra wide, lightweight, non-magnetic aluminium toe cap.
- Greater lightness.
- Anti-abrasion toe cap for greater resistance to impacts and friction.

Uses:

- For general use where safety footwear is required. Comfortable, breathable and lightweight.
- Particularly suitable for work in restocking, handling and industry.



► STREET BLACK AND BLUE SHOE S1P-72350

► STREET BLACK AND RED SHOE S1P-72350

REF.	€	8 41 4299	Mbox	
72350BB38S1P	71,08	657722	1	5 38
72350BB39S1P	71,08	657746	1	5 39
72350BB40S1P	71,08	657760	1	5 40
72350BB41S1P	71,08	657784	1	5 41
72350BB42S1P	71,08	657807	1	5 42
72350BB43S1P	71,08	657821	1	5 43
72350BB44S1P	71,08	657845	1	5 44
72350BB45S1P	71,08	657869	1	5 45
72350BB46S1P	71,08	657883	1	5 46
72350BB47S1P	71,08	657906	1	5 47

REF.	€	8 41 4299	Mbox	
72350BR36S1P	71,08	657920	1	5 36
72350BR37S1P	71,08	657944	1	5 37
72350BR38S1P	71,08	657968	1	5 38
72350BR39S1P	71,08	656831	1	5 39
72350BR40S1P	71,08	656855	1	5 40
72350BR41S1P	71,08	656770	1	5 41
72350BR42S1P	71,08	656879	1	5 42
72350BR43S1P	71,08	656893	1	5 43
72350BR44S1P	71,08	656916	1	5 44
72350BR45S1P	71,08	656930	1	5 45
72350BR46S1P	71,08	656954	1	5 46
72350BR47S1P	71,08	656978	1	5 47

S1P (SB A E FO P) HRO CI SRC.*UNTIL END OF STOCK.

S1P (SB A E FO P) HRO CI SRC.*UNTIL END OF STOCK.



► INDUSTRY BLACK SHOE S1P-72351

► INDUSTRY EASY SHOE S1P-72352

REF.	€	8 41 4299	Mbox	
72351B36S1P	70,50	657678	1	5 36
72351B37S1P	70,50	657692	1	5 37
72351B38S1P	70,50	657272	1	5 38
72351B39S1P	70,50	657296	1	5 39
72351B40S1P	70,50	657319	1	5 40
72351B41S1P	70,50	657333	1	5 41
72351B42S1P	70,50	657357	1	5 42
72351B43S1P	70,50	657371	1	5 43
72351B44S1P	70,50	657395	1	5 44
72351B45S1P	70,50	657418	1	5 45
72351B46S1P	70,50	657432	1	5 46
72351B47S1P	70,50	657456	1	5 47

REF.	€	8 41 4299	Mbox	
72352B38S1P	71,09	657470	1	5 38
72352B39S1P	71,09	657494	1	5 39
72352B40S1P	71,09	657517	1	5 40
72352B41S1P	71,09	657531	1	5 41
72352B42S1P	71,09	657555	1	5 42
72352B43S1P	71,09	657579	1	5 43
72352B44S1P	71,09	657593	1	5 44
72352B45S1P	71,09	657616	1	5 45
72352B46S1P	71,09	657630	1	5 46
72352B47S1P	71,09	657654	1	5 47

S1P (SB A E FO P) HRO CI SRC.*UNTIL END OF STOCK.

S1P (SB A E FO P) HRO CI SRC.*UNTIL END OF STOCK.

RUNNING RANGE

CLASSIC RUN

- Footwear certified as Category II according to EN ISO 20345:11.
- Non-metallic safety toe cap and antiperforation inner sole.

Sole:

- Bi-density Rubber+EVA: Rubber for increased thermal resistance, hydrocarbon resistance and slip resistance SRC. EVA for lightness and cushioning.
- Sole design for safety and durability: wide grooves, braking zones and shock absorption.
- Combination of materials and latest technologies available to achieve a very sporty and lightweight sole.

Style:

- Two product lines:
 - RUN MODELS: Water repellent microfibre + Printing, S3 resistant to penetration and water absorption.
 - CELL MODELS: Water repellent S3 microfibre, resistant to water penetration and water absorption + CPU weave for greater resistance.
- Padded collar, EXTRA padded gusset tongue and ergonomically shaped insole for greater comfort and fit.
- Bellota Mesh EXTRA padded lining 3D: better ventilation and extra comfort.
- Wide last.

Uses:

- For general use where safety footwear is required. Technology and lightness.



► CELL BLACK SHOE S3-72223

► RUN BLACK SHOE S3-7223NB

REF.	€	8 41 4299	Mbox	
72223B-38 S3	91,43	637076	1	5 38
72223B-39 S3	91,43	637090	1	5 39
72223B-40 S3	91,43	637113	1	5 40
72223B-41 S3	91,43	637137	1	5 41
72223B-42 S3	91,43	637151	1	5 42
72223B-43 S3	91,43	637458	1	5 43
72223B-44 S3	91,43	637175	1	5 44
72223B-45 S3	91,43	637199	1	5 45
72223B-46 S3	91,43	637212	1	5 46
72223B-47 S3	91,43	637236	1	5 47

REF.	€	8 41 4299	Mbox	
72223NB-38 S3	88,59	654226	1	5 38
72223NB-39 S3	88,59	654240	1	5 39
72223NB-40 S3	88,59	654264	1	5 40
72223NB-41 S3	88,59	654288	1	5 41
72223NB-42 S3	88,59	654301	1	5 42
72223NB-43 S3	88,59	654325	1	5 43
72223NB-44 S3	88,59	654349	1	5 44
72223NB-45 S3	88,59	654363	1	5 45
72223NB-46 S3	88,59	654387	1	5 46
72223NB-47 S3	88,59	654400	1	5 47

S3 (SB A E FO P WRU) SRC.

S3 (SB A E FO P WRU) SRC. *UNTIL END OF STOCK.



► RUN BLACK SHOE S1P-72224NB

► KNIT BLACK SHOE S1P-72224KB

REF.	€	8 41 4299	Mbox	
72224NB-38 S1P	77,71	654660	1	5 38
72224NB-39 S1P	77,71	654684	1	5 39
72224NB-40 S1P	77,71	654707	1	5 40
72224NB-41 S1P	77,71	654721	1	5 41
72224NB-42 S1P	77,71	654745	1	5 42
72224NB-43 S1P	77,71	654769	1	5 43
72224NB-44 S1P	77,71	654783	1	5 44
72224NB-45 S1P	77,71	654806	1	5 45
72224NB-46 S1P	77,71	654820	1	5 46
72224NB-47 S1P	77,71	654844	1	5 47

REF.	€	8 41 4299	Mbox	
72224KB-36 S1P	78,33	654622	1	5 36
72224KB-37 S1P	78,33	654646	1	5 37
72224KB-38 S1P	78,33	654424	1	5 38
72224KB-39 S1P	78,33	654448	1	5 39
72224KB-40 S1P	78,33	654462	1	5 40
72224KB-41 S1P	78,33	654486	1	5 41
72224KB-42 S1P	78,33	654509	1	5 42
72224KB-43 S1P	78,33	654523	1	5 43
72224KB-44 S1P	78,33	654547	1	5 44
72224KB-45 S1P	78,33	654561	1	5 45
72224KB-46 S1P	78,33	654585	1	5 46
72224KB-47 S1P	78,33	654608	1	5 47

S1P (SB A E FO P) SRC.*UNTIL END OF STOCK.

S1P (SB A E FO P) SRC.

NEW RUN

- Footwear certified as Category II according to EN ISO 20345:2022.
- Fibreglass safety toe cap and textile anti-puncture insole for maximum anti-puncture protection.
- Biomechanically tested shoes to respect the natural footprint and provide maximum comfort at work, reducing fatigue.
- ESD-certified models that divert the electrostatic discharge accumulated in the body towards the outside, preventing damage to electronic components.

Sole:

- Bi-density PU + PU: Resistance to hydrocarbons and maximum SR anti-slip performance.
- New OPEN CELL PRO sole for stability and maximum comfort: braking zones, shock absorption, textured shank, maximum flex.
- Combination of materials and latest technologies available to achieve a very sporty and lightweight sole.

Style:

- Fortitex™ anti-cut resistance and outstanding durability, while maintaining flexibility and breathability. Water repellent to keep moisture away.
- Anti-abrasion rubber reinforcements on toe, sides and back to withstand the most demanding jobs.
- Ergonomic, padded collar with EXTRA padded gusseted tongue for a perfect, comfortable fit.
- New generation PU+GEL comfort insole for optimal shock absorption and stability, fully ventilated for maximum breathability.
- Bellota Mesh EXTRA padded lining 3D: better ventilation and extra comfort.
- Wide last.

Uses:

- For general use where safety footwear is required. Technology and lightness.
- ESD-certified models, suitable for work in chemical companies, in the automotive industry or in the assembly of electronic components.



▶ RUN WHITE SHOE S3S-RUNB

REF.	€	8 41 4299	Mbox	
RUNBS3S36	63,00	073683	1 10	36
RUNBS3S37	63,00	073768	1 10	37
RUNBS3S38	63,00	073805	1 10	38
RUNBS3S39	63,00	073836	1 10	39
RUNBS3S40	63,00	073874	1 10	40
RUNBS3S41	63,00	073904	1 10	41
RUNBS3S42	63,00	073928	1 10	42
RUNBS3S43	63,00	073959	1 10	43
RUNBS3S44	63,00	073997	1 10	44
RUNBS3S45	63,00	074048	1 10	45
RUNBS3S46	63,00	074086	1 10	46
RUNBS3S47	63,00	074123	1 10	47
RUNBS3S48	63,00	074161	1 10	48

S3S (SB A E PS WPA) FO SR CI - ESD.

▶ RUN BLACK SHOE S3S-RUNN

REF.	€	8 41 4299	Mbox	
RUNNS3S36	63,00	074574	1 10	36
RUNNS3S37	63,00	074598	1 10	37
RUNNS3S38	63,00	074611	1 10	38
RUNNS3S39	63,00	074635	1 10	39
RUNNS3S40	63,00	074659	1 10	40
RUNNS3S41	63,00	074673	1 10	41
RUNNS3S42	63,00	074697	1 10	42
RUNNS3S43	63,00	074758	1 10	43
RUNNS3S44	63,00	074772	1 10	44
RUNNS3S45	63,00	074819	1 10	45
RUNNS3S46	63,00	074987	1 10	46
RUNNS3S47	63,00	074833	1 10	47
RUNNS3S48	63,00	074918	1 10	48

S3S (SB A E PS WPA) FO SR CI - ESD.



▶ RUN YELLOW SHOE S3S-RUNA

REF.	€	8 41 4299	Mbox	
RUNAS3S36	63,00	072105	1 10	36
RUNAS3S37	63,00	072150	1 10	37
RUNAS3S38	63,00	072174	1 10	38
RUNAS3S39	63,00	072235	1 10	39
RUNAS3S40	63,00	072280	1 10	40
RUNAS3S41	63,00	073454	1 10	41
RUNAS3S42	63,00	073478	1 10	42
RUNAS3S43	63,00	073508	1 10	43
RUNAS3S44	63,00	073577	1 10	44
RUNAS3S45	63,00	073607	1 10	45
RUNAS3S46	63,00	073621	1 10	46
RUNAS3S47	63,00	073645	1 10	47
RUNAS3S48	63,00	073669	1 10	48

S3S (SB A E PS WPA) FO SR CI - ESD.

▶ RUN ORANGE SHOE S3S-RUNJ

REF.	€	8 41 4299	Mbox	
RUNJS3S36	63,00	071740	1 10	36
RUNJS3S37	63,00	071764	1 10	37
RUNJS3S38	63,00	071788	1 10	38
RUNJS3S39	63,00	071801	1 10	39
RUNJS3S40	63,00	071825	1 10	40
RUNJS3S41	63,00	071849	1 10	41
RUNJS3S42	63,00	071870	1 10	42
RUNJS3S43	63,00	071917	1 10	43
RUNJS3S44	63,00	071955	1 10	44
RUNJS3S45	63,00	071986	1 10	45
RUNJS3S46	63,00	072044	1 10	46
RUNJS3S47	63,00	072068	1 10	47
RUNJS3S48	63,00	072082	1 10	48

S3S (SB A E PS WPA) FO SR CI - ESD.

CORE RANGE

- Footwear certified as Category II according to EN ISO 20345 standard.
- Safety steel toe cap and antiperforation textile inner sole.

Sole:

- SRC/SR dual density PU + PU: maximum anti-slip performance certifiable according to current standards.
- Sporty sole design for maximum comfort.

Style:

- Lightweight, breathable suede leather with perforations on the sides.
- Padded lining, collar and gusseted tongue for greater comfort and better breathability.
- Anti-abrasion toe cap and back area for greater resistance to impacts and friction.

Uses:

- For general use where breathable and lightweight safety footwear is required.
- Particularly suitable for working in indoor or dry environments in the building industry.



► CORE SHOE S1P-FTW3050

REF.	€	8 41 4299	Mbox		
FTW303650S1P	41,55	700930	1	5	36
FTW303750S1P	41,55	700954	1	5	37
FTW303850S1P	41,55	700978	1	5	38
FTW303950S1P	41,55	700992	1	5	39
FTW304050S1P	41,55	701012	1	5	40
FTW304150S1P	41,55	701036	1	5	41
FTW304250S1P	41,55	701050	1	5	42
FTW304350S1P	41,55	701074	1	5	43
FTW304450S1P	41,55	701098	1	5	44
FTW304550S1P	41,55	701111	1	5	45
FTW304650S1P	41,55	701135	1	5	46
FTW304750S1P	41,55	701159	1	5	47

S1P (SB A E FO P) SRC.

*In the process of recertification under standard 20345:2022 CAT S1PS (SB A E PS WPA) FO SR.

VOLTA RANGE

- Footwear certified as Category II according to EN ISO 20345 standard.
- Fibreglass safety toecap and non-metallic, non-perforated textile insole.

Sole:

- SRC/SR dual density PU + PU: maximum anti-slip performance certifiable according to current standards.
- Sporty sole design for maximum comfort.

Style:

- S1PS version: Nylon and microfibre combined for durability, lightweight and breathability.
- S3S version: Water and abrasion resistant Nobuck waterproof leather.
- Padded lining, collar and gusseted tongue for greater comfort and better breathability.
- Anti-abrasion back area for greater resistance to impacts and friction.

Uses:

- For general use where safety footwear is required. Comfortable, breathable and lightweight.
- For a wide range of sectors and industries: assembly of electronic components.



► VOLTA SHOE S1P-FTW4091

REF.	€	8 41 4299	Mbox		
FTW403691S1P	49,01	701418	1	5	36
FTW403791S1P	49,01	701432	1	5	37
FTW403891S1P	49,01	701456	1	5	38
FTW403991S1P	49,01	701470	1	5	39
FTW404091S1P	49,01	701494	1	5	40
FTW404191S1P	49,01	701517	1	5	41
FTW404291S1P	49,01	701531	1	5	42
FTW404391S1P	49,01	701555	1	5	43
FTW404491S1P	49,01	701579	1	5	44
FTW404591S1P	49,01	701593	1	5	45
FTW404691S1P	49,01	701616	1	5	46
FTW404791S1P	49,01	701630	1	5	47

S1P (SB A E FO P) SRC.

*In the process of recertification under standard 20345:2022 CAT S1PS (SB A E PS WPA) FO SR.



► VOLTA SHOE S3-FTW4051

REF.	€	8 41 4299	Mbox		
FTW403651S3	53,27	701654	1	5	36
FTW403751S3	53,27	701678	1	5	37
FTW403851S3	53,27	701692	1	5	38
FTW403951S3	53,27	701715	1	5	39
FTW404051S3	53,27	701739	1	5	40
FTW404151S3	53,27	701753	1	5	41
FTW404251S3	53,27	701777	1	5	42
FTW404351S3	53,27	701791	1	5	43
FTW404451S3	53,27	701814	1	5	44
FTW404551S3	53,27	701838	1	5	45
FTW404651S3	53,27	701852	1	5	46
FTW404751S3	53,27	701876	1	5	47

S3 (SB A E FO P WRU) SRC.

*In the process of recertification under standard 20345:2022 CAT S3S (SB A E PS WPA) FO SR.

RACE RANGE

- Footwear certified as Category II according to EN ISO 20345:11. S3 Safety shoe.
- Non-metallic safety fiberglass toe cap and antiperforation textile inner sole.

Sole:

- Bi-density PU + PU SRC/SR: maximum anti-slip performance certifiable according to current standards.
- Modern and sporty sole design combining comfort and cushioning.

Style:

- Breathable mesh with inner waterproofing foil to combine water resistance and feet ventilation.
- Padded lining, collar and gusseted tongue for greater comfort and better ventilation.
- CONFORT PLUS insole made from open-cell foam that provides greater comfort and relieves pressure. Antistatic stitching.
- Anti-abrasion toe cap and back area for greater resistance to impacts and friction.
- Fiberglass toe cap, lighter.

Uses:

- For general use where safety footwear is required. Comfortable, breathable and lightweight.
- Particularly suitable for work in restocking, handling and industry.



► RACE SHOE S3-FTW5074

REF.	€	8 41 4299	Mbox	
FTW503674S3	58,61	701890	1	5 36
FTW503774S3	58,61	701913	1	5 37
FTW503874S3	58,61	701937	1	5 38
FTW503974S3	58,61	701951	1	5 39
FTW504074S3	58,61	701975	1	5 40
FTW504174S3	58,61	701999	1	5 41
FTW504274S3	58,61	702019	1	5 42
FTW504374S3	58,61	702064	1	5 43
FTW504474S3	58,61	702088	1	5 44
FTW504574S3	58,61	702101	1	5 45
FTW504674S3	58,61	702125	1	5 46
FTW504774S3	58,61	702149	1	5 47

S3 (SB A E FO P WRU) SRC.

*In the process of recertification under standard 20345:2022 CAT S3S (SB A E PS WPA) FO SR.

CHEF RANGE

- Footwear certified as Category II according to EN ISO 20345 standard.
- Metal safety toe cap.

Sole:

- SRC/SR dual density PU + PU: Maximum anti-slip performance certifiable according to current standards.
- Sole design for safety and durability: wide grooves, braking zones, shock absorption, textured shank and raised toe and rear profiles.
- Footwear certified as Category II according to EN ISO 20345:11.

Style:

- Strong and resistant water repellent microfibre.
- Dark grey textile inner reinforcement.
- Steel toecap.

Uses:

- For use in the food, cleaning, laboratories and sanitary industries, among others.



► CHEF SHOE S2-72323

REF.	€	8 41 4299	Mbox	
72323CGS238	30,00	026245	1	10 38
72323CGS239	30,00	026320	1	10 39
72323CGS240	30,00	026474	1	10 40
72323CGS241	30,00	026511	1	10 41
72323CGS242	30,00	026559	1	10 42
72323CGS243	30,00	026597	1	10 43
72323CGS244	30,00	026634	1	10 44
72323CGS245	30,00	026672	1	10 45
72323CGS246	30,00	026719	1	10 46
72323CGS247	30,00	026771	1	10 47

S2 (SB A E FO WRU) SRC.

*In the process of recertification under standard 20345:2022 CAT S2 (SB A E WPA) FO SR.

► CHEF SHOE S2-72324

REF.	€	8 41 4299	Mbox	
72324CGS238	31,00	026818	1	10 38
72324CGS239	31,00	027136	1	10 39
72324CGS240	31,00	027211	1	10 40
72324CGS241	31,00	027297	1	10 41
72324CGS242	31,00	027372	1	10 42
72324CGS243	31,00	027594	1	10 43
72324CGS244	31,00	027655	1	10 44
72324CGS245	31,00	027686	1	10 45
72324CGS246	31,00	027709	1	10 46
72324CGS247	31,00	027730	1	10 47

S2 (SB A E FO WRU) SRC.

*In the process of recertification under standard 20345:2022 CAT S2 (SB A E WPA) FO SR.



► CHEF SHOE S2 72325NN

REF.	€	8 41 4299	Mbox	
72325NNS238	30,00	040869	1	10 38
72325NNS239	30,00	040883	1	10 39
72325NNS240	30,00	040906	1	10 40
72325NNS241	30,00	040920	1	10 41
72325NNS242	30,00	040968	1	10 42
72325NNS243	30,00	040982	1	10 43
72325NNS244	30,00	041002	1	10 44
72325NNS245	30,00	041026	1	10 45
72325NNS246	30,00	041040	1	10 46
72325NNS247	30,00	041064	1	10 47

S2 (SB A E FO WRU) SRC.

*In the process of recertification under standard 20345:2022 CAT S2 (SB A E WPA) FO SR.

► CHEF SHOE S2 72326NN

REF.	€	8 41 4299	Mbox	
72326NNS238	31,00	041088	1	10 38
72326NNS239	31,00	041101	1	10 39
72326NNS240	31,00	041125	1	10 40
72326NNS241	31,00	041149	1	10 41
72326NNS242	31,00	041163	1	10 42
72326NNS243	31,00	041187	1	10 43
72326NNS244	31,00	041200	1	10 44
72326NNS245	31,00	041224	1	10 45
72326NNS246	31,00	041248	1	10 46
72326NNS247	31,00	041262	1	10 47

S2 (SB A E FO WRU) SRC.

*In the process of recertification under standard 20345:2022 CAT S2 (SB A E WPA) FO SR.

WATER RANGE

- Footwear certified as Category II according to EN ISO 20345 standard.
- Metallic safety toe cap and antiperforation insole.
- PVC outsole and upper.
- Extra reinforcement at insole and ankle.
- Grooved heel area for easier removal.

Uses:

- For general use where safety waterproof footwear is required.



► PVC GREEN BOOT S5-72242

REF.	€	8 41 4299	Mbox	
72242-39 S5	18,15	531862	1	6 39
72242-40 S5	18,15	531886	1	6 40
72242-41 S5	18,15	531909	1	6 41
72242-42 S5	18,15	531923	1	6 42
72242-43 S5	18,15	531947	1	6 43
72242-44 S5	18,15	531961	1	6 44
72242-45 S5	18,15	531985	1	6 45
72242-46 S5	18,15	532005	1	6 46
72242-47 S5	18,15	532029	1	6 47

S5 (SB A E FO P WR) SRC.

*In the process of recertification under standard 20345:2022 CAT S5 (SB A E P WR) FO SR.



► PVC BLACK BOOT S5 72243

REF.	€	8 41 4299	Mbox	
72243-39 S5	18,15	532104	1	6 39
72243-40 S5	18,15	532128	1	6 40
72243-41 S5	18,15	532142	1	6 41
72243-42 S5	18,15	532166	1	6 42
72243-43 S5	18,15	532180	1	6 43
72243-44 S5	18,15	532203	1	6 44
72243-45 S5	18,15	532227	1	6 45
72243-46 S5	18,15	532241	1	6 46
72243-47 S5	18,15	532265	1	6 47

S5 (SB A E FO P WR) SRC.

*In the process of recertification under standard 20345:2022 CAT S5 (SB A E P WR) FO SR.



► PVC BLACK OB BOOT-72241

REF.	€	8 41 4299	Mbox	
72241B-38 OB	11,97	696448	1	6 38
72241B-39 OB	11,97	687040	1	6 39
72241B-40 OB	11,97	687064	1	6 40
72241B-41 OB	11,97	687088	1	6 41
72241B-42 OB	11,97	687101	1	6 42
72241B-43 OB	11,97	687125	1	6 43
72241B-44 OB	11,97	687149	1	6 44
72241B-45 OB	11,97	687163	1	6 45
72241B-46 OB	11,97	687187	1	6 46
72241B-47 OB	11,97	687200	1	6 47

OB SRA.

LACES



► 120 CM ROUND BLACK LACE ACC2090

REF.	€	8 41 4299	A mm
ACC2012090	2,22	708394	1 1.200

Length suitable for footwear with 5-7 pairs of eyelets.



► 120 CM ROUND BLACK/RED LACE ACC2092

REF.	€	8 41 4299	A mm
ACC2012092	2,22	708400	1 1.200

Length suitable for footwear with 5-7 pairs of eyelets.



► 120 CM OVOID BLACK LACE ACC2170

REF.	€	8 41 4299	A mm
ACC2112090	2,22	708417	1 1.200

Length suitable for footwear with 5-7 pairs of eyelets.



► 120 CM OVOID BLACK LACE ACC2190

REF.	€	8 41 4299	A mm
ACC2112070	2,22	708424	1 1.200

Length suitable for footwear with 5-7 pairs of eyelets.

INSOLES

2x GEL
Open CELL
AeroFlow

*Increased stability
and shock absorption*

*Lightweight, shock absorption
and shape recovery*

*Maximum breathability for cool,
dry footwear*

TECHNOLOGIES

With advanced **OPEN CELL** and **double GEL** technologies for maximum user comfort.



▶ SHOE INSOLE MODEL RUN PGEL

REF.	€	8 41 4299	
PGEL36-38	6,99	076387	10
PGEL39-41	6,99	076424	10
PGEL42-44	6,99	076486	10
PGEL45-48	6,99	076547	10

Sizes available

Multiple sizes available with trimming option for a perfect fit.

S 36-38 **L** 42-44
M 39-41 **XL** 45-48

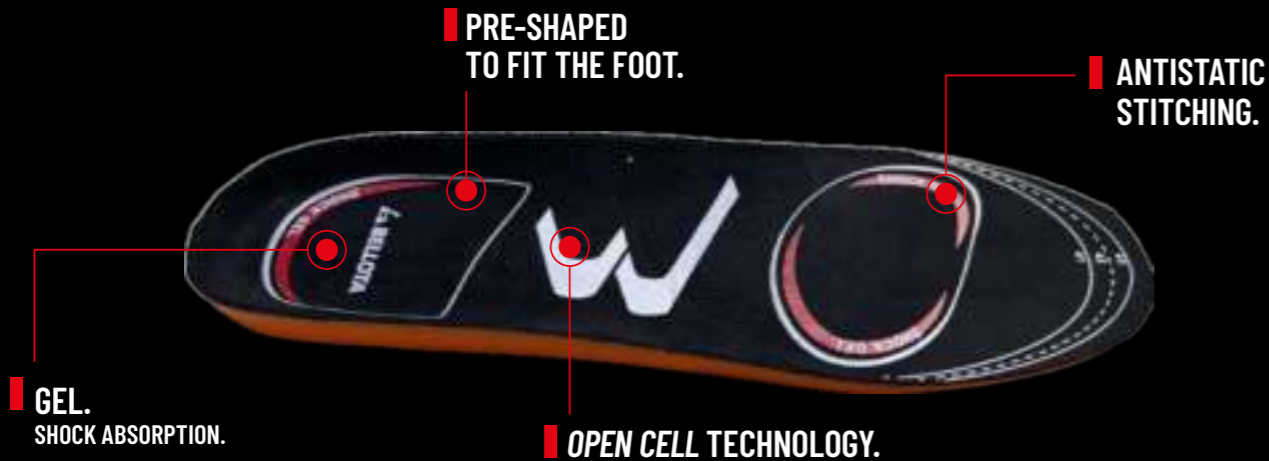

KNEE PADS



▶ KNEE PAD 72803

REF.	€	8 41 4299	
72803	18,11	639193	6



▶ PROFESSIONAL KNEE PAD 72805

REF.	€	8 41 4299	
72805	24,02	281941	1

Gel filled.



▶ EXTRA PROFESSIONAL KNEE PAD 72804

REF.	€	8 41 4299	
72804	29,80	639179	6

Certificated Category I-EN 14404. Neoprene inner lining. Gel filled.

HANDLES FOR AGRICULTURE

Wooden handles

- Premium quality.
- Ergonomic design matches the shape of each tool.
- Light and pleasant to touch handles.
- Perfect varnished finishing.



COMMITMENT TO QUALITY AND THE ENVIRONMENT:

These handles are made from PEFC Certified wood. This certificate guarantees that 100% of the wood used comes from properly managed forests according to strict, internationally approved commercial, environmental and financial requirements, while at the same time, optimising forest resources throughout the entire manufacturing process.



The gardening handles have FSC Certification – Forest Stewardship Council®, which guarantees that the wood used comes from responsibly managed forests in accordance with international standards which include environmental, commercial and financial aspects defining minimum good management levels throughout the world.

See our certified tools.

Carbon fiber handles

- Made with last generation materials.
- Ergonomic design matches the shape of each tool:
 - Studied and analyzed shapes to fit hands, handling position and each tool use: better comfort, handling and better hand feeling.
 - Side grooves that reinforces the anti-slip effect.
 - Bottom shape conceived for a better handling to improve ergonomomy and security.
- Unbreakable handle, made in three different materials:
 - Fiberglass core for greater resistance.
 - Technical polymer body latest generation.
 - TPS elastomer for greater ergonomics.

Oval-shaped handle

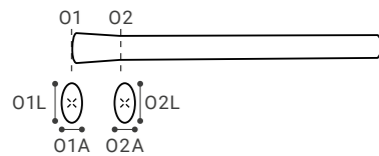

Round handle

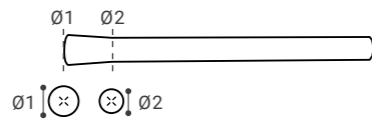

Rectangular handle

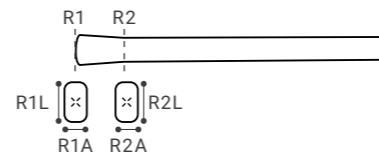

VARNISHED HANDLES FOR HOES



M1 HANDLE WITH ANTI-ROTATION SYSTEM

REF.	€	8 41 4299	L mm	Ø1	Ø2	Destino	
HDLM1W1000APH	9,53	697575	6	1.000	32,5	27	M1 hoe anti-rotation s.
HDLM1W1200APH	11,80	697599	6	1.200	32,5	27	M1 hoe anti-rotation s.
HDLM1W1400APH	13,00	697612	6	1.400	32,5	27	M1 hoe anti-rotation s.

M4 HANDLE WITH ANTI-ROTATION SYSTEM

REF.	€	8 41 4299	L mm	Ø1	Ø2	Destino	
HDLM4W1000APH	11,53	697636	6	1.000	41,5	33	M4 hoe anti-rotation s.
HDLM4W1200APH	15,94	697650	6	1.200	41,5	33	M4 hoe anti-rotation s.
HDLM4W1400APH	17,59	697674	6	1.400	41,5	33	M4 hoe anti-rotation s.



M6 HANDLE WITH ANTI-ROTATION SYSTEM

REF.	€	8 41 4299	L mm	Ø1	Ø2	Destino	
HDLM6W1000APH	13,44	697698	6	1.000	46,5	35	M6 hoe anti-rotation s.
HDLM6W1200APH	17,67	697711	6	1.200	46,5	35	M6 hoe anti-rotation s.
HDLM6W1400APH	19,49	697735	6	1.400	46,5	35	M6 hoe anti-rotation s.



HANDLE FOR LIGHTWEIGHT AIR HOE ML

REF.	€	8 41 4299	L mm	Ø1 A	Ø1 L	Ø2 A	Ø2 L	Destino	
ML500	12,06	651980	3	500	36,5	40,5	30	34	L1/L2/L3/L4/L5
ML1200	11,59	651966	3	1.200	36,5	40,5	30	34	L1/L2/L3/L4/L5



HANDLE FOR HOE M0

REF.	€	8 41 4299	L mm	Ø1	Ø2	Destino	
M 0-900	8,15	154801	12	900	30	26	Hoes / Pick
M 0-1200	9,74	158793	12	1.200	30	26	Hoes / Pick



HANDLE FOR HOE M1

REF.	€	8 41 4299	L mm	Ø1	Ø2	Destino	
M 1-400	5,30	659979	6	400	32	30	228/230/232
M 1-900	8,29	154108	12	900	32	30	Hoes / Pick
M 1-1000	9,42	132137	12	1.000	32	30	Hoes / Pick
M 1-1200	10,27	158809	12	1.200	32	30	Hoes / Pick
M 1-1400	11,31	612134	12	1.400	32	30	Hoes / Pick



HANDLE FOR HOE M2

REF.	€	8 41 4299	L mm	Ø1	Ø2	Destino	
M 2-900	9,13	154207	12	900	35	32	Hoes / Pick
M 2-1200	11,67	157871	12	1.200	35	32	Hoes / Pick
M 2-1400	12,87	612158	12	1.400	35	32	Hoes / Pick



HANDLE FOR HOE M3

REF.	€	8 41 4299	L mm	Ø1	Ø2	Destino	
M 3-900	9,46	154306	12	900	37,5	34	Hoes / Pick
M 3-1200	11,75	158816	12	1.200	37,5	34	Hoes / Pick
M 3-1400	12,98	612172	12	1.400	37,5	34	Hoes / Pick



HANDLE FOR HOE M4

REF.	€	8 41 4299	L mm	Ø1	Ø2	Destino	
M 4-900	10,05	154405	12	900	41	37	Hoes / Pick
M 4-1100	13,88	218343	12	1.100	41	37	Hoes / Pick
M 4-1200	13,88	157864	12	1.200	41	37	Hoes / Pick
M 4-1400	15,30	612196	12	1.400	41	37	Hoes / Pick



HANDLE FOR HOE M5

REF.	€	8 41 4299	L mm	Ø1	Ø2	Destino	
M 5-900	10,94	154504	12	900	43	39	Hoes / Pick
M 5-1200	13,88	157857	12	1.200	43	39	Hoes / Pick
M 5-1400	15,30	612219	12	1.400	43	39	Hoes / Pick



▶ HANDLE FOR HOE M6

REF.	€	8 41 4299	L mm	Ø1	Ø2	Destino
M 6-900	11,70	154603	12	900	46 42	Hoes / Pick
M 6-1200	15,38	157840	6	1.200	46 42	Hoes / Pick
M 6-1400	16,95	612233	6	1.400	46 42	Hoes / Pick



▶ HANDLE FOR HOE M7

REF.	€	8 41 4299	L mm	Ø1	Ø2	Destino
M 7-900	14,61	154702	6	900	50 45	Hoes / Pick / Hoe
M 7-1200	18,14	157833	6	1.200	50 45	Hoes / Pick / Hoe
M 7-1400	20,03	612257	6	1.400	50 45	Hoes / Pick / Hoe



▶ HANDLE FOR HOE LENGTH 1400

REF.	€	8 41 4299	L mm	Ø1 A	Ø1 L	Ø2 A	Ø2 L	Destino
M 108	11,67	086331	12	900	35	48	29 41	108



▶ HANDLE FOR HOE 127

REF.	€	8 41 4299	L mm	R1 A	R1 L	R2 A	R2 AL	Destino
M 127	11,67	086355	12	900	30	39	28 34	127



▶ SHORT HANDLE FOR HOE M242-A

REF.	€	8 41 4299	L mm	Ø1	Ø2	Destino
M 242-A	4,77	037296	12	360	35 28	242-A



▶ CARBON FIBER HANDLE FOR HOE / PICK LENGTH 900

REF.	€	8 41 4299	L mm	Ø1	Ø2	Destino
M 6 CF	33,93	625394	12	900	46 42	Hoes / Pick
M 7 CF	33,93	625417	12	900	50 45	Hoes / Pick / Hoe

VARNISHED HANDLES FOR FORKS



▶ STRAIGHT HANDLE FOR FORK 901

REF.	€	8 41 4299	L mm	Ø1	Ø2	Destino
M 901 LR 120	9,96	156317	12	1.200	28 37	901/903/904/910



▶ CURVED HANDLE FOR FORK 901

REF.	€	8 41 4299	L mm	Ø1	Ø2	Destino
M 901 LC 135	11,67	156324	12	1.350	28 37	901/903/904/910



▶ D HANDLE FOR FORK 901

REF.	€	8 41 4299	L mm	Ø1	Ø2	Destino
M 901 AC 75	12,19	156300	12	750	38 37	901/903/904/910



▶ D HANDLE FOR FORK 901

REF.	€	8 41 4299	L mm	Ø1	Ø2	Destino
M 902 AC 75	19,58	246971	12	750	38 37	902/911

VARNISHED HANDLES FOR RAKES



▶ HANDLE FOR RAKE 952

REF.	€	8 41 4299	L mm	Ø1	Ø2	Destino
M 952	7,90	157918	12	1.200	18,5 28	950 / 951 / 952
M 952 L	8,89	033106	12	1.500	15 28	950 / 951 / 952



HANDLES FOR SCYTHES



▶ HANDLE FOR SCYTHES 2503

REF.	€	8 41 4299	L mm	Destino
M 2503 R	20,90	541830	6 1.365	2503 / 2506 / 2509
A 2503	7,76	994827	6	2531 / 2532 / 2533

Handles for scythes. Ergonomic and long-lasting.

VARNISHED HANDLES FOR BROOMS

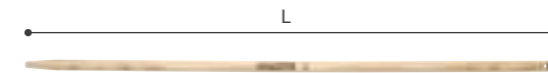

▶ HANDLE FOR BROOMS 3020

REF.	€	8 41 4299	L mm	Ø1	Ø2	Destino
M 3020	7,86	050608	12	1.200	16 25	Brooms



▶ HANDLE FOR PLASTIC BROOMS 3034

REF.	€	8 41 4299	L mm	Ø1	Ø2	Destino
M 3034	7,86	069327	12	1.400	18 23,5	Brooms



VARNISHED HANDLES FOR LONG WOODEN HANDLE TOOLS



▶ HANDLE FOR LONG WOODEN HANDLES TOOLS 3080

REF.	€	8 41 4299	L mm	Ø1	Ø2	Destino
M 3080	7,86	216646	6	1.500	13 30	Long handled tools



VARNISHED HANDLES FOR SLEDGE HAMMERS-WEDGE



▶ HANDLE FOR SLEDGE HAMMERS-WEDGE 5460

REF.	€	8 41 4299	L mm	Ø1	Ø2	Destino
M 5460-3	13,80	149951	12	890		5460-3



VARNISHED HANDLES FOR PHYTO 0% RANGE



NEW

▶ PHYTO 0% LONG HANDLE LHT3085

REF.	€	8 41 4299	L mm	Ø1	Ø2	Destino
M3085	9,01	706291	12	820	1.500 30	LHT3085/LHT308610/ LHT308612
M3087	9,01	705713	12	890	1.500 30	LHT3087

VARNISHED HANDLES FOR SHOVELS AND SPADES



▶ D HANDLE FOR ALUMINIUM SHOVEL 5520

REF.	€	8 41 4299	L mm	Ø1	Ø2	Destino
M 5520 A	15,38	158250	12	865	29 35	5520/5522



▶ LONG HANDLE FOR ALUMINIUM SHOVEL 5520

REF.	€	8 41 4299	L mm	Ø1	Ø2	Destino
M 5520 L	14,83	157505	12	1.200	24 38	5520/5522



▶ D HANDLE FOR ALUMINIUM SHOVEL 5525

REF.	€	8 41 4299	L mm	Ø1	Ø2	Destino
M 5525 A	15,21	422252	12	610	25 33,5	5525



▶ T HANDLE FOR SPADES 5604

REF.	€	8 41 4299	L mm	Ø1	Ø2	Destino
M 5604 M	11,90	150322	12	700	23,5 38	5604
M 5573 M	11,67	641677	12	700	26,9 38	5573



▶ D HANDLE FOR SPADES 5604

REF.	€	8 41 4299	L mm	Ø1	Ø2	Destino
M 5604 A	13,80	150346	12	700	23,5 38	5604
M 5573 A	13,55	641639	12	700	26,9 38	5573



▶ LONG HANDLE FOR SPADES 5604

REF.	€	8 41 4299	L mm	Ø1	Ø2	Destino
M 5604 L	12,74	150360	12	985	23,5 38	5604 / 1111
M 5573 L	12,50	641653	12	985	26,9 38	5573 / 914-5 ECO



▶ LONG HANDLE FOR SHOVEL 5609

REF.	€	8 41 4299	L mm	Ø1	Ø2	Destino
M 5609 L	8,87	069914	12	985	22 36	5609



VARNISHED HANDLES FOR AXES



▶ HANDLE FOR AXE 8131

REF.	€	8 41 4299	L mm	Ø1 A	Ø1 L	Ø2 A	Ø2 L	Destino
M 8131-300	6,65	930832	12	480	23,5 44	19 39		8131



▶ HANDLE FOR AXE 8130 C

REF.	€	8 41 4299	L mm	Ø1 A	Ø1 L	Ø2 A	Ø2 L	Destino
M 8130-300 C	5,69	708172	12	380				8130-300N/8130-400N
M 8130-500 C	6,37	708196	12	400				8130-500 N
M 8130-600 C	6,46	708219	12	420				8130-600 N
M 8130-700 C	6,83	708233	12	450				8130-700N/8130-800N
M 8130-1000	11,75	708714	12	600	31 55 26 46			8130-1000/8130-1000N
M 8130-1200	13,17	708738	12	700	32 57 27 52			8130-1200/8130-1200N
M 8130-1500	14,68	708752	6	800	34 60 28 54			8130-1500/8130-1500N
M 8130-2000	15,73	708776	6	800	36 63 29 57			8130-2000/8130-2000N



NEW

VARNISHED HANDLES FOR RASPS



▶ HANDLE FOR RASPS 4090

REF.	€	8 41 4299	L mm	Destino
4090-7	6,12	184341	24 100	Files

NON VARNISHED HANDLES FOR HOES

- Economic line that comes from the rejects of our premium range.
- Can have knots, cracks, cracks with putty filler, small lacks of material (these imperfections do not affect tool functionality).
- Ergonomic design matches the shape of each tool.
- Light handles.

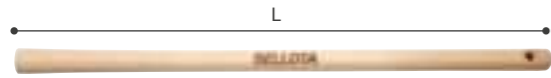

► NON VARNISHED HANDLES FOR HOES LEGNTH 600

REF.	€	8 41 4299	L mm	Ø1	Ø2	Destino
M 1-600 SB	2,73	606164	36	600	32 30	



► NON VARNISHED HANDLES FOR HOES LEGNTH 900

REF.	€	8 41 4299	L mm	Ø1	Ø2	Destino
M0-900 SB	4,04	591149	12	900	30 26	Hoes
M1-900 SB	4,23	590104	12	900	32 30	Hoes
M2-900 SB	4,56	591163	12	900	35 32	Hoes
M3-900 SB	4,82	591187	12	900	37,5 34	Hoes
M4-900 SB	4,99	587494	12	900	41 37	Hoes
M5-900 SB	5,43	591200	12	900	43 39	Hoes
M6-900 SB	5,81	590142	12	900	46 42	Hoes / Pick



► NON VARNISHED HANDLES FOR HOES LEGNTH 1200

REF.	€	8 41 4299	L mm	Ø1	Ø2	Destino
M0-1200 SB	4,82	591224	12	1.200	30 26	Hoes
M1-1200 SB	5,09	591248	12	1.200	32 30	Hoes
M2-1200 SB	5,80	591262	12	1.200	35 32	Hoes
M3-1200 SB	5,68	590999	12	1.200	37,5 34	Hoes
M4-1200 SB	6,67	591286	12	1.200	41 37	Hoes
M5-1200 SB	6,67	590166	12	1.200	43 39	Hoes
M6-1200 SB	7,63	591309	12	1.200	46 42	Hoes / Pick
M7-1200 SB	9,01	591323	12	1.200	50 45	Hoes / Pick

NON VARNISHED HANDLES FOR BROOMS

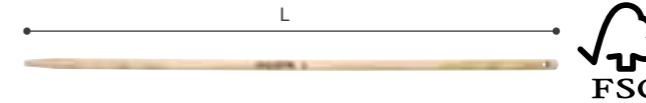

► NON VARNISHED HANDLE FOR BROOMS 3020

REF.	€	8 41 4299	L mm	Ø1	Ø2	Destino
M 3020 SB	3,78	591378	12	1.200	16 25	Brooms

NON VARNISHED HANDLES FOR SPADES



► NON VARNISHED D HANDLE FOR SPADES 5604

REF.	€	8 41 4299	L mm	Ø1	Ø2	Destino
M 5604-A SB	6,85	591477	12	868	23,5 38	5604/5573



► NON VARNISHED LONG HANDLE FOR SPADES 5604

REF.	€	8 41 4299	L mm	Ø1	Ø2	Destino
M 5604-L SB	6,32	591453	12	985	23,5 38	5604/5573

HANDLES FOR HOES

HANDLES: M 900, M 1200 AND M 1400

REF.	Destino
M0	Hoes: 240, 242-0
M1	Hoes: 1-A, 1-B, 7-A, 182, 228-A, 228-B, 228-C, 228-D, 229-A, 230-A, 230-B, 232-A, 232-B, 232-C, 242-A, 326, 343-B-30, 344-A and 344-B
M2	Hoes: 276 Forks: 1020-A
M3	Hoes: 8-A, 8-B, 8-C, 72-A, 72-B, 80-A, 80-B, 81-000, 81-00, 81-0, 82-B, 85-A, 85-B, 85-C, 89-A, 90-B, 91-A and 91-B
M4	Hoes: 1-C, 2-A, 2-B, 3-A, 3-B, 3-C, 4-A, 4-B, 10-A, 53-A, 53-B, 58-0, 58-A, 69-A, 72-C, 72-D, 77-D, 79-C, 80-E, 80-H, 81-A, 81-B, 83-A, 84-A, 84-B, 84-C, 84-E, 87-A, 87-C, 87-D, 87-E, 150-A, 150-C, 302-0, 302-A, 320, 325, 335, 337-0, 337-A, 338-0, 338-A, 340-0, 340-A and 340-B Forks: 1001-0, 1001-A and 1018
M5	Hoes: 327 and 328, Fork 912-3
M6	Hoes: 5, 11-A, 69-B, 87-F, 87-G, 95-A, 95-C, 252-0, 252-A, 252-B and 252-C, Forks: 1002-A and 1002-B Picks: 5001-A and 5001-B
M7	Hoes: 43-0 and 43-B, Mattocks: 801-0, Picks: 5001-C and 5001-D, Hoe: 820, Mattocks: 805-A

LIGHTWEIGHT AIR HOE

REF.	Destino
M1200	Hoes: L1, L3, L5
M500	Hoes: L2, L4

HANDLES FOR CONSTRUCTION

Wooden handles

- Premium quality.
- Ergonomic design matches the shape of each tool.
- Light and pleasant to touch handles.
- Perfect varnished finishing.



COMMITMENT TO QUALITY AND THE ENVIRONMENT:

These handles are made from PEFC Certified wood. This certificate guarantees that 100% of the wood used comes from properly managed forests according to strict, internationally approved commercial, environmental and financial requirements, while at the same time, optimising forest resources throughout the entire manufacturing process.



The gardening handles have FSC Certification – Forest Stewardship Council®, which guarantees that the wood used comes from responsibly managed forests in accordance with international standards which include environmental, commercial and financial aspects defining minimum good management levels throughout the world.

See our certified tools.

Carbon fiber handles

- Made with last generation materials.
- Ergonomic design matches the shape of each tool:
 - Studied and analyzed shapes to fit hands, handling position and each tool use: better comfort, handling and better hand feeling.
 - Side grooves that reinforces the anti-slip effect.
 - Bottom shape conceived for a better handling to improve ergonomomy and security.
- Unbreakable handle, made in three different materials:
 - Fiberglass core for greater resistance.
 - Technical polymer body latest generation.
 - TPS elastomer for greater ergonomics.

Oval-shaped handle

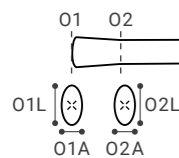

Conical handle

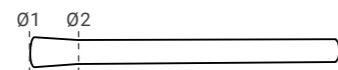

Rectangular handle

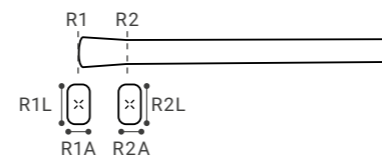

VARNISHED HANDLES FOR HAMMERS



▶ CARBON FIBER HANDLE FOR HOE / PICK LENGHT 900

REF.	€	8 41 4299	L mm	Destino
M 6 CF	33,93	625394	12 900	Hoes / Pick
M 7 CF	33,93	625417	12 900	Hoes / Pick / Hoe



▶ HANDLE FOR GARDEN TOOLS 5016

REF.	€	8 41 4299	L mm	O1 A	O1 L	O2 A	O2 L	Destino
M 5016-00	12,96	185430	6 900	41	55	35	49	Long handled tools



▶ HANDLE FOR SLEDGE HAMMERS 5200N

REF.	€	8 41 4299	L mm	Destino
M 5200-2N	8,70	373950	12 600	5200-2
M 5200-3N	8,70	373998	12 600	5200-3
M 5200-4N	11,59	374049	12 700	5200-4
M 5200-5N	12,35	374117	12 800	5200-5
M 5200-6N	12,35	374155	12 800	5200-6



▶ HANDLE FOR SLEDGE HAMMERS 5200

REF.	€	8 41 4299	L mm	Destino
M 5200-2	8,70	149401	12 600	5203-2
M 5200-3	8,45	075748	12 600	5203-3
M 5200-4	11,23	149500	12 700	5203-4
M 5200-5	11,99	075779	12 800	5203-5
M 5200-6	12,35	075809	12 800	5203-6
M 5200-8	13,55	075830	12 900	5200-8

* With the handle you will also receive the wedges.

* With the handle you will also receive the wedges.



▶ HANDLE FOR SLEDGE HAMMER 5200

REF.	€	8 41 4299	L mm	O1 A	O1 L	O2 A	O2 L	Destino
M 5200-4 CF	33,93	625455	12 700	33,4	49,9	29,2	45,7	5200-3/5200-4
M 5200-6 CF	39,84	625479	12 900	33,4	49,9	29,2	45,7	5200-5/5200-6/5460-3CF



▶ HANDLE FOR DRILLING HAMMER 5308N-5310

REF.	€	8 41 4299	L mm	O1 A	O1 L	O2 A	O2 L	Destino
M 5308-0 N	3,87	626773	12 280	25	38	31	40	5308-0 N
M 5308-A N	3,76	353242	12 280	25	38	31	40	5308-A N
								5308-B N

* With the handle you will also receive the wedges.



▶ CARBON FIBER HANDLE FOR DRILLING HAMMER 5308N-5310

REF.	€	8 41 4299	L mm	O1 A	O1 L	O2 A	O2 L	Destino
M 5308 CF	15,44	625431	12 270	26,8	40	26	39,5	5308

Carbon fibre handles for sledgehammers 5308 and 5310.



▶ HANDLE FOR DRILLING HAMMER 5312

REF.	€	8 41 4299	L mm	Ø1	Ø2	Destino
M 5312	5,25	040449	12 400	39	33	5312-400



▶ HANDLE FOR PICKAXE 5938

REF.	€	8 41 4299	L mm	Destino
M 5938	5,53	205268	12 386	5938

* With the handle you will also receive the wedges.



▶ HANDLE FOR DRILLING HAMMER 5305

REF.	€	8 41 4299	L mm	Destino
M 5305	4,99	149609	12 235	5305-0 / 5305-A

* With the handle you will also receive the wedges.



▶ HANDLE FOR DRILLING HAMMER 5308

REF.	€	8 41 4299	L mm	Destino
M 5308-0	3,54	149708	12 280	5308-0
M 5308-A	3,76	149807	12 280	5308-A
M 5308-B	3,76	149906	12 280	5308-B

* With the handle you will also receive the wedges.



▶ HANDLE FOR DRILLING HAMMER 5310

REF.	€	8 41 4299	L mm	Destino
M 5310-A	3,87	626797	12 260	5310-A / 5310-B
M 5310-C	3,87	626810	12 260	5310-C / 5310-D



▶ HANDLE FOR PICKAXE 5931N-5932N-5933N

REF.	€	8 41 4299	L mm	Destino
M 5931-0 N	3,87	635560	12 310	5931 AN/5932 -AN/ 5933- AN
M 5931-A N	4,06	635584	12 310	5931 AN/5932 -AN/ 5933- AN
M 5931-B N	4,28	635607	12 335	5931-BN/5932 BN

* With the handle you will also receive the wedges.



▶ HANDLE FOR CLAW HAMMER 8002

REF.	€	8 41 4299	L mm	Destino
M 8002-13	3,99	611977	12 300	8002-13
M 8002-16	4,34	611991	12 325	8002-16
M 8002-20	5,18	612011	12 325	8002-20
M 8002-24	5,18	612035	12 345	8002-24

* With the handle you will also receive the wedges.



▶ HANDLE FOR HAMMER 8004

REF.	€	8 41 4299	12	L mm	Destino
M 8004-A	4,34	111118	12	325	8004 A



▶ HANDLE CARPENTER HAMMER 8005

REF.	€	8 41 4299	12	L mm	Destino
M 8005-16	3,15	151800	12	259	8005-16
M 8005-A	3,38	151107	12	269	8005-A
M 8005-B	3,38	151206	12	279	8005-B
M 8005-C	3,75	151305	12	289	8005-C
M 8005-D	3,75	151404	12	304	8005-D
M 8005-E	3,75	151503	12	319	8005-E
M 8005-F	3,83	151602	12	334	8005-F

* With the handle you will also receive the wedges.



▶ HANDLE FOR NAIL HAMMER 8007 AND PICKAXE

REF.	€	8 41 4299	12	L mm	Ø1	Ø2	Destino
M 8007-A	2,91	151909	12	300	25,5	22	8007-A
M 8007-B	3,27	152005	12	300	26,6	23	8007-B / 5931-0 5932-00 / 5932-0 5933-00 / 5933-0
M 8007-C	3,27	152104	12	335	27,8	24	8007-C / 5931-A 5932-A / 5933-A
M 8007-D	3,47	152203	12	335	29	25	8007-D / 5931-B 5932-B / 242-A
M 8007-E	3,87	152302	12	360	30	26	8007-E
M 8007-F	3,99	152401	12	360	31,2	27	8007-F



▶ HANDLE FOR AXE HAMMER 8008

REF.	€	8 41 4299	12	L mm	Destino
M 8008	4,39	035810	12	375	8008

* With the handle you will also receive the wedges.



▶ HANDLE FOR NAIL HAMMER 8009-8011

REF.	€	8 41 4299	12	L mm	Destino
M 8011-A	4,19	152500	12	300	8011-A
M 8011-B	4,19	152609	12	310	8011-B / 8009-A
M 8011-C	4,15	152708	12	320	8011-C / 8009-B
M 8011-D	4,21	152807	12	330	8011-D / 8009-C
M 8011-E	4,73	152906	12	345	8011-E / 8009-D
M 8011-F	4,73	153002	12	360	8011-F / 8009-E
M 8011-G	5,23	153101	12	380	8011-G
M 8011-H	5,23	153200	12	400	8011-H

* With the handle you will also receive the wedges.



▶ HANDLE FOR SHUTTERING HAMMER 8017

REF.	€	8 41 4299	12	L mm	Ø1 A	Ø1 L	Ø2 A	Ø2 L	Destino
M 8017-0**	4,72	487152	12	400	29	41	20,2	32,2	5936-A 300 / 5936-B 400 8017-0 / 8017-A
M 8017-A	4,73	153705	12	450	29	41	20,2	32,2	5935-A 400 / 5935-B 600 5936-C 500 / 5937-A 400
M 8017-B	4,88	153804	12	450	31	43	21,9	33,9	8017-B
M 8017-C	5,45	153903	12	450	33	45	23,5	35,5	8017-C
M 8017-D	5,45	154009	12	450	35	47	25	37	8017-D

* With the handle you will also receive the wedges.
** UNTIL END OF STOCK.



▶ HANDLE FOR SHUTTERING HAMMER 8030

REF.	€	8 41 4299	12	L mm	Ø1 A	Ø1 L	Ø2 A	Ø2 L	Destino
M 8030	5,52	469905	12	450	27,5	40	23	34,5	8030



▶ CARBON FIBER HANDLE FOR SHUTTERING HAMMER 8030

REF.	€	8 41 4299	12	L mm	Ø1 A	Ø1 L	Ø2 A	Ø2 L	Destino
M 8030 CF	15,09	636703	12	500	26,4	38,4	24,8	36,8	8030



▶ HANDLE FOR NYLON HAMMER 8050

REF.	€	8 41 4299	12	L mm	Destino
M 8050-25	5,52	584622	12	254	8050-25
M 8050-32	6,07	586725	12	279	8050-35
M 8050-38	6,53	589061	12	284	8050-38
M 8050-44	6,92	590746	12	305	8050-44
M 8050-50	9,47	593327	12	335	8050-50

* With the handle you will also receive the wedges.



▶ HANDLE FOR RUBBER Mallet 8053

REF.	€	8 41 4299	12	L mm	Ø1 A	Ø1 L	Ø2 A	Ø2 L	Destino
M 8053-250	6,24	446753	12	320	27	31	23	27	8053-250
M 8053-500	6,38	447064	12	340	32	38	27,3	33,2	8053-500
M 8053-750	6,57	447286	12	380	32	38	26,7	32,7	8053-750

VARNISHED HANDLES FOR SHOVELS



▶ T HANDLE FOR SHOVEL 5501-5502

REF.	€	8 41 4299	12	L mm	Destino
M 5501 M	9,19	150001	12	700	5501 / 5502



▶ D HANDLE FOR SHOVEL 5501-5502

REF.	€	8 41 4299	12	L mm	Destino
M 5501 A	13,02	150100	12	700	5501 / 5502



▶ LONG HANDLE FOR SHOVEL 5501-5502

REF.	€	8 41 4299	12	L mm	Destino
M 5501 L	13,94	150209	12	985	5501 / 5502



▶ LONG HANDLE FOR SHOVEL 5559

REF.	€	8 41 4299	6	L mm	Ø1	Ø2	Destino
M 5559 L	14,83	792140	6	1.320	34	27	5559

VARNISHED HANDLES FOR SCRAPER



▶ HANDLE FOR SCRAPER 5701

REF.	€	8 41 4299	12	L mm	Destino
M 5701 L	8,92	792942	12	985	5701/5709/5710
M 5701 L 120	10,25	907520	12	1.200	5701/5709/5710



▶ M4 HANDLE WITH ANTI-ROTATION SYSTEM

REF.	€	8 41 4299	12	L mm	Ø1	Ø2	Destino
HDLM4W1000APH	11,53	697636	12	1.000	41,5	33	5702A/PRK5753BP
HDLM4W1200APH	15,94	697650	12	1.200	41,5	33	5702A/PRK5753BP
HDLM4W1400APH	17,59	697674	12	1.400	41,5	33	5702A/PRK5753BP

VARNISHED HANDLES FOR TROWELS



▶ HANDLE FOR TROWELS 5842

REF.	€	8 41 4299	24	L mm	Destino
M 5842-D	1,50	150407	24	100	Trowels
M 5842-H	1,59	150506	24	100	Trowels



▶ HANDLE FOR TROWELS HDL01BWPB

REF.	€	8 41 4299	24	L mm	Destino
HDL01BWPB	3,09	690576	24	100	Trowels

NON VARNISHED HANDLES FOR SHOVELS



▶ NON VARNISHED T HANDLE FOR SHOVEL 5501-5502

REF.	€	8 41 4299	8 41 4299	L mm	Destino
M 5501 MSB	3,97	591514	12	700	5501-5502



▶ NON VARNISHED HANDLES FOR SHOVEL 5556

REF.	€	8 41 4299	8 41 4299	L mm	Destino
M 5556-2 C SB	6,11	590203	12	1.170	5556-2



▶ NON VARNISHED HANDLES FOR SHOVEL 5556

REF.	€	8 41 4299	8 41 4299	L mm	Destino
M 5556-2 R SB	4,86	590180	12	1.170	5556-2



▶ NON VARNISHED LONG HANDLE FOR SHOVELS 108

REF.	€	8 41 4299	8 41 4299	L mm	Destino
MF108SBG	6,33	590180	12	1.170	108

NON VARNISHED HANDLES FOR SCRAPER



▶ HANDLE FOR SCRAPER 5701

REF.	€	8 41 4299	8 41 4299	L mm	Destino
M 5701 L SB	4,29	792942	12	985	5701/5709/5710
M 5701 L 120 SB	4,91	907520	12	1.200	5701/5709/5710



▶ HANDLE FOR PICKAXE 5938

REF.	€	8 41 4299	8 41 4299	L mm	Ø1	Ø2	Destino
M 5938 SB	2,12	205268	12	386	36	32	5938

WEDGES FOR WOODEN HANDLES

- PATENTED Fibreglass wedges ensuring the perfect joint between head and handle.
- Greater safety: improved joint between handle and head.
- Extra strong joint: increases the required traction strength.
- Excellent strength: its fibreglass and polyamide provide high corrosion resistance and bad weather and temperature protection.

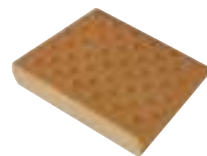

▶ 6 WEDGES FOR SLEDGE HAMMERS AND DRILLING HAMMERS

REF.	€	8 41 4299	8 41 4299	Destino
8975 BL	6,11	572643	50	

CONTENTS 8975 BL

REF.	UDS.	
Wedge N° 7	3	5200-2, 5308-AN, 5308-BN, 8130-300/400/500
Wedge N° 8	3	5200-3, 5200-4, 5200-5, 5200-6, 5200-8, 8130-600/700/800

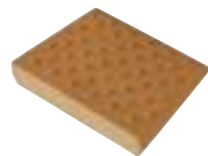

▶ 6 WEDGES FOR HAMMERS AND DRILLING HAMMERS

REF.	€	8 41 4299	8 41 4299	Destino
8976 BL	4,31	572667	50	

CONTENTS 8976 BL

REF.	UDS.	
Wedge N° 1	1	8005-16, 8005-A, 8005-B, 8011-A
Wedge N° 2	2	8002-13, 8005-C, 8005-D, 8009-A, 8011-B
Wedge N° 3	1	8002-16, 8004-A, 8005-E, 8005-F, 8009-B, 8009-C, 8011-C, 8011-D
Wedge N° 4	1	5308-0, 8009-D, 8009-E, 8011-E, 8011-F
Wedge N° 6	1	8002-20, 8002-24, 8011-G, 8011-H

HANDLES FOR WORKSHOP

HANDLES FOR FILES



▶ PLASTIC HANDLE FOR FILES 4089

REF.	€	8 41 4299	8 41 4299	L mm	Destino
4089-1	1,74	465204	24	92	Files
4089-2	2,02	465303	24	92	Files
4089-3	2,02	465402	24	105	Files
4089-4	2,26	465501	24	105	Files
4089-7	2,78	096897	24	105	Files



▶ BIMATERIAL HANDLE FOR FILES 4093

REF.	€	8 41 4299	8 41 4299	L mm	Destino
4093-A1	4,05	108736	24	120	Files
4093-A2	4,05	109634	24	120	Files
4093-A3	4,05	109696	24	120	Files
4093-A4	3,91	109849	24	120	Files
4093-B1	4,05	138764	24	120	Files
4093-B2	4,05	138870	24	120	Files
4093-B3	4,05	138931	24	120	Files
4093-B4	3,91	138979	24	120	Files
4093-B5	4,05	139037	24	120	Files



▶ HANDLE FOR FILES 4090

REF.	€	8 41 4299	8 41 4299	L mm	Destino
4090-2	1,54	465709	24	85	Files
4090-3	1,78	465808	24	95	Files
4090-4	1,79	465907	24	108	Files
4090-5	1,99	466003	24	120	Files
4090-6	2,02	466102	24	133	Files

PLASTIC HANDLES 4089

REF.	
4089-1	4004-4 / 4006-4 / 4040-5 / 4041-4 / 4041-4,5 / 4042-3
4089-2	4001-4 / 4002-4 / 4003-4 / 4004-6 / 4005-4 / 4006-6 / 4040-6 / 4041-5 / 4041-6 / 4042-4 / 4081-4 / 4104-6
4089-3	4004-8 / 4005-6 / 4006-8 / 4041-7 / 4041-8 / 4042-5 / 4042-6 / 4042-7 / 4081-5 / 4104-8
4089-4	4001-6 / 4002-6 / 4003-6 / 4004-10 / 4004-12 / 4005-8 / 4006-10 / 4006-12 / 4007-6 / 4008-6 / 4042-8 / 4042-9 / 4081-6 / 4081-7 / 4081-8 / 4087-6 / 4101-6 / 4101-8 / 4102-6 / 4102-8 / 4104-10
4089-7	4001-8 / 4002-8 / 4003-8 / 4005-10 / 4008-8 / 4008-10 / 4042-10 / 4081-10 / 4101-10 / 4102-10 / 4103-8

HANDLE 4090

REF.	
4090-2	4001-4 / 4002-4 / 4003-4 / 4004-6 / 4006-6 / 4040-5 / 4041-5 / 4042-5 / 4081-5 / 4104-6
4090-3	4001-6 / 4002-6 / 4003-6 / 4004-8 / 4005-6 / 4006-8 / 4007-6 / 4008-6 / 4040-6 / 4041-6 / 4042-6 / 4081-6 / 4087-6 / 4101-6 / 4102-6 / 4104-8
4090-4	4001-8 / 4002-8 / 4003-8 / 4004-10 / 4004-12 / 4005-8 / 4006-10 / 4006-12 / 4008-8 / 4041-7 / 4041-8 / 4042-7 / 4042-8 / 4081-7 / 4081-8 / 4101-8 / 4102-8 / 4103-8
4090-5	4001-10/4002-10/4003-10/ 4005-10 / 4008-10 / 4042-9 / 4042-10/4081-10/4101-10/ 4102-10 / 4104-10
4090-6	4001-12 / 4001-14 / 4002-12 / 4002-14 / 4003-12 / 4003-14 / 4005-12 / 4101-12

HANDLE 4090-7

REF.	
4090-7	4132-14

BIMATERIAL HANDLE 4093

REF.	
4093-A1	4001-14 / 4002-14 / 4003-14
4093-A2	4003/4001-10 / 4001-12 / 4002-10 / 4002-12 / 4003-12 / 4101-12
4093-A3	4003-10 / 4008-10 / 4101-10 / 4102-10
4093-A4	4001-8 / 4002-8 / 4003-8 / 4008-8 / 4101-8 / 4102-8 / 4103-8
4089-7	4001-8 / 4002-8 / 4003-8 / 4008-8 / 4101-8 / 4102-8 / 4103-8
4093-B1	4005-10 / 4005-12 / 4042-10 / 4081-10
4093-B2	4004-12 / 4005-8 / 4006-12 / 4041-8 / 4042-8 / 4042-9 / 4081-8
4093-B3	4001-6 / 4002-6 / 4003-6 / 4004-10 / 4005-6 / 4006-10 / 4007-6 / 4008-6 / 4041-6 / 4041-7 / 4042-5 / 4042-6 / 4042-7 / 4081-5 / 4081-6 / 4081-7 / 4087-6 / 4101-6 / 4102-6 / 4104-10
4093-B4	4001-4 / 4002-4 / 4003-4 / 4004-6 / 4004-8 / 4005-4 / 4006-6 / 4006-8 / 4040-6 / 4042-4 / 4081-4 / 4104-6 / 4050
4093-B5	4104-8 / 004-4 / 4006-4 / 4040-5 / 4041-4 / 4041-4,5 / 4041-5 / 4042-3

POINT OF SALE SOLUTIONS

Bellota offers solutions for optimum exhibition of the tool at the point of sale.



► UNIVERSAL DISPLAY

REF.	€	8 41 4299	g	A mm	B mm	C mm
8990EN	794,50	704730	1	4.500	450	1.000 2.570



► DISPLAY WITH WHEELS

REF.	€	8 41 4299	g	A mm	B mm	C mm
3955	349,00	622416	1	16.000	410	2.100 830



► DISPLAY STAND FOR CERAMIC CUTTERS EXPCORT

REF.	€	8 41 4299	g	A mm	B mm	C mm
EXPCORT	394,95	053609	1	29.000	1.050	780 1.100

NEW



► DISPLAY FOR MIXERS EXPMEZ

REF.	€	8 41 4299	g	A mm	B mm	C mm
EXPMEZ	194,95	014150	1	8.500	390	780 300

NEW



► TILE CUTTER DISPLAY

REF.	€	8 41 4299	g	A mm	B mm	C mm
8940V	371,93	627091	1	18.250	38	79 90



► LARGE TILE CUTTER DISPLAY

REF.	€	8 41 4299	g	A mm	B mm	C mm
8942V	167,35	698893	1	13.000	380	280 1.000



► LONG HANDLE DISPLAY

REF.	€	8 41 4299	g	A mm	B mm	C mm
8970 V	110,81	926699	1	9.800	470	400 760



► LONG HANDLE TOOL DISPLAY

REF.	€	8 41 4299	g	A mm	B mm	C mm
8944V	501,97	697407	1	0		



► SMALL SCISSORS DISPLAY

REF.	€	8 41 4299	g	A mm	B mm	C mm
8943V	108,80	698886	1	4.000	450	250 400



► POINT CHISELS, CHISELS AND COLD CHISELS DISPLAY

REF.	€	8 41 4299	g	A mm	B mm	C mm
8952 V	74,95	926613	1	3.830	420	220 105



FOOTWEAR DISPLAY

REF.	€	8 41 4299	g	A mm	B mm	C mm
72294N	410,55	705560	1	4.000	1.790	575 280



HOE DISPLAY

REF.	€	8 41 4299	A mm	B mm	C mm
HOEEXP	255,00	710984	1	650	380 140

* VALID FOR THE SPANISH MARKET.



ACCESSORIES FOR DISPLAY 899EN

REF.	€	8 41 4299	
8990PUAN	4,64	704785	1 8990E
8990PALETAN	17,42	704822	1 8990E
8990CPOP	41,01	704846	1 8990E
8990CPRON	31,88	704860	1 8990E
8990CALZADON	12,23	704808	1 8990E
8990DUON	6,12	015904	1 8990E
8990ESTAN	71,40	016420	1 8990E

ACCESSORIES FOR DISPLAY

REF.	€	8 41 4299	
5840C	0,74	621754	1
6485G	0,65	601633	1
6485P	0,57	601640	1
50014HANGER	0,39	709889	1



GENERAL TERMS AND CONDITIONS OF SALE

PRICES

This Price List includes recommended Retail prices including standard packaging. The Prices do not include Value Added Tax (VAT), or/and any other taxes that maybe applicable to the transaction or on the goods.

PRICE CHANGE

In the case of a change of price, the price that is in effect on the date of delivery will be applied.

ORDERS

Orders are not considered firm until they are expressly accepted by BELLOTA.

MINIMUM ORDER

The minimum amount of each order will be agreed for each order.

DELIVERY

The goods will be delivered within a reasonable time from the signing of the contract. Every delivery time that might be specified will be purely informative and estimated, not being binding for Bellota Herramientas, S.L.U.

TRANSPORT

Unless something else is agreed between Bellota Herramientas S.L.U. and Customer, transport method and transport service providers will be chosen by seller.

TRANSPORT EXCEPTIONS

Buyer will verify that products have been delivered correctly. In case buyer finds a non conformity, he will inform Bellota Herramientas, S.L.U. within 24 hours. After this period of time, the seller will not accept any claim related with transport.

PAYMENT TERM

Payments will be made by buyer to seller 60 net from invoice date.

INVOICES ISSUES

Purchases will only be considered if the invoice has been issued. Pending orders at the end of the year will be deemed not valid.

GUARANTEE

Bellota Herramientas, S.L.U. offers a guarantee of its product manufacturing from the delivery date. In order for the purchaser to establish his guarantee rights, he must report any product defaults within a maximum of 15 days from the date of delivery..

This guarantee does not extend to that damage which do not affect the supplied goods, except when the damage has been caused by negligence exclusively attributable to Bellota Herramientas, S.L.U.

The guarantee does not include natural wear or damage originated after the delivery of the goods when these are due to wrong or careless manipulation or handling of the goods, to improper storage or to inadequate repair work carried out by the purchaser or a third party.

CONDITIONS SET BY CUSTOMERS

Bellota Herramientas S.L.U. general terms of sale are the only applicable ones. The conditions of purchase established by customers in their orders which are in contradiction with these Terms and Conditions, will only be valid when Bellota Herramientas, S.L.U. has accepted them in a written agreement.

RESERVE OF OWNERSHIP

All delivered goods will be owned by Bellota Herramientas S.L.U. until the whole purchasing Price has been paid. Once buyer has made all payments, seller will transfer the ownership of the goods to the buyer.

APPLICABLE JURISDICTION AND LAW

Disputes between both parties in relation to the interpretation and/or fulfilment of the contract will be subject to the Courts of San Sebastián (Guipúzcoa-Spain) with express waiver to any other that might correspond, Spanish Law being applicable.

Notes:

BARCODE

To complete the BARCODE of each reference, the numbers included in the column corresponding to this symbol must be preceded with the numbers: 8414299.

**This price list supersedes all previous ones.
This price list enters in force 15/01/2024.**



BELLOTA HERRAMIENTAS, S.L.U
UROLA Nº 10. APTDO. Nº 1. 20230 LEGAZPI.
GUIPUZKOA. SPAIN



C/ Urola , 10.
20230. Legazpi.
Guipúzcoa. Spain.

T. (+34) 943 73 90 00
F. (+34) 943 73 15 01

www.bellota.com